

PacketCable™ HD Voice

HDV NCS Specification

PKT-SP-HDV-NCS-I04-120823

ISSUED

Notice

This PacketCable specification is the result of a cooperative effort undertaken at the direction of Cable Television Laboratories, Inc. for the benefit of the cable industry and its customers. This document may contain references to other documents not owned or controlled by CableLabs®. Use and understanding of this document may require access to such other documents. Designing, manufacturing, distributing, using, selling, or servicing products, or providing services, based on this document may require intellectual property licenses from third parties for technology referenced in this document.

Neither CableLabs nor any member company is responsible to any party for any liability of any nature whatsoever resulting from or arising out of use or reliance upon this document, or any document referenced herein. This document is furnished on an "AS IS" basis and neither CableLabs nor its members provides any representation or warranty, express or implied, regarding the accuracy, completeness, noninfringement, or fitness for a particular purpose of this document, or any document referenced herein.

© Cable Television Laboratories, Inc., 2009 - 2012.

DISCLAIMER

This document is published by Cable Television Laboratories, Inc. ("CableLabs®").

CableLabs reserves the right to revise this document for any reason including, but not limited to, changes in laws, regulations, or standards promulgated by various agencies; technological advances; or changes in equipment design, manufacturing techniques, or operating procedures described, or referred to, herein. CableLabs makes no representation or warranty, express or implied, with respect to the completeness, accuracy, or utility of the document or any information or opinion contained in the report. Any use or reliance on the information or opinion is at the risk of the user, and CableLabs shall not be liable for any damage or injury incurred by any person arising out of the completeness, accuracy, or utility of any information or opinion contained in the document.

This document is not to be construed to suggest that any affiliated company modify or change any of its products or procedures, nor does this document represent a commitment by CableLabs or any cable member to purchase any product whether or not it meets the described characteristics. Nothing contained herein shall be construed to confer any license or right to any intellectual property, whether or not the use of any information herein necessarily utilizes such intellectual property. This document is not to be construed as an endorsement of any product or company or as the adoption or promulgation of any guidelines, standards, or recommendations.

Document Status Sheet

Document Control Number:	PKT-SP-HDV-NCS-I04-120823			
Document Title:	HDV NCS Specification			
Revision History:	I01 - Released 02/26/09 as DECT-NCS I02 - Released 09/17/09 I03 - Released 04/12/12 I04 - Released 08/23/12 as HDV-NCS			
Date:	August 23, 2012			
Status:	Work in Progress	Draft	Issued	Closed
Distribution Restrictions:	Author Only	CL/Member	CL/Member/Vendor	Public

Key to Document Status Codes

- Work in Progress** An incomplete document, designed to guide discussion and generate feedback that may include several alternative requirements for consideration.

- Draft** A document in specification format considered largely complete, but lacking review by Members and vendors. Drafts are susceptible to substantial change during the review process.

- Issued** A stable document, which has undergone rigorous member and vendor review and is suitable for product design and development, cross-vendor interoperability, and for certification testing.

- Closed** A static document, reviewed, tested, validated, and closed to further engineering change requests to the specification through CableLabs.

Trademarks

CableCARD™, CableHome®, CableLabs®, CableNET®, CableOffice™, CablePC™, CAFÉ™, DCAS™, DOCSIS®, DPoE™, EBIF™, eDOCSIS™, EuroDOCSIS™, EuroPacketCable™, Go2BroadbandSM, InGeNeOs™, M-Card™, M-CMTS™, OCAP™, OpenCable™, PacketCable™, PCMM™, PeerConnect™, and tru2way® are marks of Cable Television Laboratories, Inc. All other marks are the property of their respective owners.

DECT™ is a trademark of ETSI.

Contents

1	SCOPE	1
1.1	Introduction and Purpose.....	1
1.2	Requirements.....	1
2	REFERENCES	2
2.1	Normative References.....	2
2.2	Informative References.....	2
2.3	Reference Acquisition.....	2
3	TERMS AND DEFINITIONS	4
4	ABBREVIATIONS AND ACRONYMS	5
5	OVERVIEW	6
5.1	DECT-NCS Reference Architecture.....	6
6	DECT-NCS REQUIREMENTS	7
6.1	General Requirements.....	7
6.2	NCS Interoperability with DECT.....	7
6.2.1	<i>NCS Line Package Event Mapping to DECT</i>	7
	TABLE 1 - DECT TO NCS EVENT MAPPING	7
6.2.2	<i>NCS Line Package Signal Mapping to DECT</i>	9
	TABLE 2 - DECT TO NCS SIGNAL MAPPING	10
6.2.3	<i>Other NCS Packages</i>	12
6.2.4	<i>Auditing</i>	12
6.2.5	<i>NCS Connection Requests</i>	12
6.2.6	<i>CODECs</i>	12

Figures

Figure 1 - E-MTA Support for High Definition Voice6

Tables

Table 1 - DECT to NCS Event Mapping7
Table 2 - DECT to NCS Signal Mapping10

This page left blank intentionally.

1 SCOPE

1.1 Introduction and Purpose

This specification includes High Definition (HD) Voice requirements for PacketCable 1.5 networks. PacketCable leverages Digital Enhanced Cordless Telephone (DECT™) specifications and wideband analog interface technologies to incorporate HD Voice. This specification defines the interoperability requirements between PacketCable 1.5 Network-based Call Signaling [NCS] and DECT protocols. Additional requirements, including requirements for the wideband analog interface, are contained in the PacketCable High Definition Voice with DECT Specification [HDV].

1.2 Requirements

Throughout this document, the words that are used to define the significance of particular requirements are capitalized. These words are:

"MUST"	This word means that the item is an absolute requirement of this specification.
"MUST NOT"	This phrase means that the item is an absolute prohibition of this specification.
"SHOULD"	This word means that there may exist valid reasons in particular circumstances to ignore this item, but the full implications should be understood and the case carefully weighed before choosing a different course.
"SHOULD NOT"	This phrase means that there may exist valid reasons in particular circumstances when the listed behavior is acceptable or even useful, but the full implications should be understood and the case carefully weighed before implementing any behavior described with this label.
"MAY"	This word means that this item is truly optional. One vendor may choose to include the item because a particular marketplace requires it or because it enhances the product, for example; another vendor may omit the same item.

2 REFERENCES

2.1 Normative References

In order to claim compliance with this specification, it is necessary to conform to the following standards and other works as indicated, in addition to the other requirements of this specification. Notwithstanding, intellectual property rights may be required to use or implement such normative references.

- [CODEC1.5] PacketCable Audio/Video Codecs, PKT-SP-CODEC1.5-I04-120412, April 12, 2012, Cable Television Laboratories, Inc.
- [HDV] PacketCable High Definition Voice Specification, PKT-SP-HDV-I04-120823, August 23, 2012, Cable Television Laboratories, Inc.
- [EN 300 444] ETSI EN 300 444, Digital Enhanced Cordless Telecommunications (DECT); Generic Access Profile (GAP), V2.1.0, June 2008.
- [NCS] PacketCable Network-Based Call Signaling Protocol, PKT-SP-NCS1.5-I04-120412, April 12, 2012, Cable Television Laboratories, Inc.

2.2 Informative References

This specification uses the following informative references.

- [AIP1.5] PacketCable Embedded MTA Analog Interface and Powering Specification, PKT-SP-AIP1.5-I02-070412, April 12, 2007.
- [CMCI] DOCSIS Cable Modem to Custom Premise Equipment Interface, CM-SP-CMCI-C01-081104, November 4, 2008, Cable Television Laboratories, Inc.
- [EN 300 175-1] ETSI EN 300 175-1, Digital Enhanced Cordless Telecommunications (DECT); Common Interface (CI); Part 1: Overview, V2.2.0, June 2008.
- [EN 300 175-2] ETSI EN 300 175-2, Digital Enhanced Cordless Telecommunications (DECT); Common Interface (CI); Part 2: Physical Layer (PHL), V2.2.0, June 2008.
- [EN 300 175-3] ETSI EN 300 175-3, Digital Enhanced Cordless Telecommunications (DECT); Common Interface (CI); Part 3: Medium Access Control (MAC) layer, June 2008.
- [EN 300 175-4] ETSI EN 300 175-4, Digital Enhanced Cordless Telecommunications (DECT); Common Interface (CI); Part 4: Data Link Control (DLC) layer, V2.2.0, June 2008.
- [EN 300 175-5] ETSI EN 300 175-5, Digital Enhanced Cordless Telecommunications (DECT); Common Interface (CI); Part 5: Network (NWK) layer, V2.2.0, June 2008.
- [EN 300 175-6] ETSI EN 300 175-6, Digital Enhanced Cordless Telecommunications (DECT); Common Interface (CI); Part 6: Identities and addressing, V2.2.0, June 2008.
- [EN 300 175-7] ETSI EN 300 175-7, Digital Enhanced Cordless Telecommunications (DECT); Common Interface (CI); Part 7: Security features, V2.2.0, June 2008.
- [EN 300 175-8] ETSI EN 300 175-8, Digital Enhanced Cordless Telecommunications (DECT); Common Interface (CI); Part 8: Speech and audio coding and transmission, V2.1.2, June 2008.
- [TS 102 527-1] ETSI TS 102 527-1, Digital Enhanced Cordless Telecommunications (DECT); New Generation DECT; Part 1: Wideband speech, V1.2.1, June 2008.

2.3 Reference Acquisition

- Cable Television Laboratories, Inc., 858 Coal Creek Circle, Louisville, CO 80027; Phone +1-303-661-9100; Fax +1-303-661-9199; <http://www.cablelabs.com>

- Internet Engineering Task Force (IETF) Secretariat, 48377 Fremont Blvd., Suite 117, Fremont, California 94538, USA, Phone: +1-510-492-4080, Fax: +1-510-492-4001.
- European Telecommunications Standards Institute (ETSI), 650, route des Lucioles, 06921 Sophia-Antipolis Cedex, France, <http://www.etsi.org/WebSite/homepage.aspx>, Tel.: +33 (0)4 92 94 42 00, Fax: +33 (0)4 93 65 47 16. Specifications can be found at <http://pda.etsi.org/pda/queryform.asp>.

3 TERMS AND DEFINITIONS

This specification uses the following terms:

Analog Line	See also Wideband Analog Interface.
Analog Port	See also Wideband Analog Interface.
Client	The term client and NCS client are used interchangeably in this document.
NCS Client	A PacketCable signaling endpoint. This specification is focused on PacketCable clients that support NCS endpoints used in customer premise equipment. The NCS client is defined in [NCS].
PacketCable endpoint	Defined in [NCS].
NCS Event	Defined in [NCS].
NCS Signal	Defined in [NCS].
Wideband Audio	The audio technology used in telephony to improve voice quality by extending the frequency range of audio signals transmitted over telephone lines to 50Hz-7kHz from the traditional 300Hz-3400Hz.
Wideband Analog Interface	The physical telephony interface that has the capability to support Wideband Audio, in addition to traditional narrowband POTS audio.

4 ABBREVIATIONS AND ACRONYMS

This specification uses the following abbreviations:

CMCI	Cable Modem to Custom Premise Equipment Interface (defined by DOCSIS®)
CMTS	Cable Modem Termination System
DECT	Digital Enhanced Cordless Telephone
DTMF	Dual-tone Multi Frequency (tones)
eCM	Embedded Cable Modem
E-MTA	Embedded Media Terminal Adaptor
FP	Fixed Part (the cordless telephone base station defined in ETSI DECT specifications)
HD	High Definition
HDV	High Definition Voice
NCS	Network-Based Call Signaling
POTS	Plain Old Telephone Service
PP	Portable Part (the cordless telephone handset defined in ETSI DECT specifications)

5 OVERVIEW

5.1 DECT-NCS Reference Architecture

The specification applies High Definition Voice requirements to NCS clients that support NCS endpoints per [NCS]. High definition voice is achieved either through interoperability with DECT base stations, referred to as Fixed Parts (FPs) or through a wideband analog interface. The high definition voice DECT air interface is specified by the next generation DECT specification [TS 102 527-1]. Interoperability between the base station and handsets is achieved through the DECT Generic Access Profile specification [EN 300 444]. [EN 300 444] mandates portions of the Common Air Interface defined in specifications [EN 300 175-1] through [EN 300 175-8]. As illustrated in Figure 1, NCS clients and FPs are integrated within E-MTA devices. The E-MTAs also support at least one analog interface to POTS phones. The behavior of an analog interface that supports High definition voice (wideband analog interface) is defined in the PacketCable High Definition Voice with DECT Specification [HDV].

Requirements for interoperability with PacketCable 1.5 networks are called out in the series of PacketCable specifications included in the normative reference section above. Requirements for interoperability between the NCS clients and FP are contained within this specification, as well as the [HDV]. Although interactions are mandated between the FP and NCS client, this specification does not mandate any specific implementation of the interface. The optional Cable Modem to Custom Premise Equipment Interface, (CMCI) interface is defined in [CMCI]. The analog line is defined in the [AIP1.5] specification.

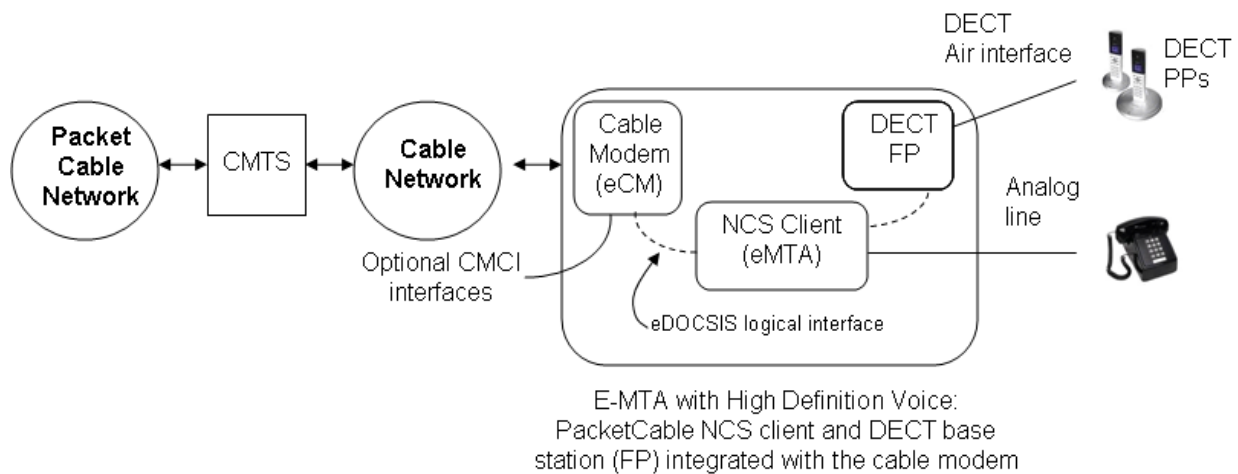

Figure 1 - E-MTA Support for High Definition Voice

One of the optional requirements for the PacketCable HD Voice Clients is the ability to implement the Network Based Call Screening (NBCS) feature. The complete description of the feature is in [HDV]. An illustration of the NBCS feature implementation in NCS environment is presented in Appendix II of this specification.

6 DECT-NCS REQUIREMENTS

This section describes the key requirements to achieve interoperability between the PacketCable 1.5 NCS endpoints and high definition voice with DECT.

6.1 General Requirements

A device compliant with this specification integrates both a PacketCable 1.5 NCS Client and a DECT FP functional element. To claim compliance with this specification, a device **MUST** support the requirements contained in [NCS] for its NCS client, the requirements contained in the PacketCable DECT specification [HDV] for its FP element, and the additional requirements contained in this specification. The term 'client' used in this specification refers to the NCS client defined in [NCS].

The NCS client **MUST** support the line packages defined in [NCS] for analog lines unless specified otherwise in this document. The NCS client **MUST** support the requirements placed on the client in the [HDV] specification.

6.2 NCS Interoperability with DECT

6.2.1 NCS Line Package Event Mapping to DECT

All events generated are processed according to [NCS] unless specified otherwise. The FP detects events based on stimulus from the PP, and the FP then makes these events known to the NCS client. The NCS client detects events from the FP and analog line in order to identify PacketCable NCS events. The NCS client **MUST** detect events from the FP. The FP **MUST** detect events from the PP as described in the subsections following Table 1, and make these events available to the NCS client. All DECT messages received are assumed to be properly formatted. Messages received that are not properly formatted are handled according to [EN 300 444].

Table 1 provides an informative summary of event mapping that is normatively described in the following subsections. Table 1 refers to the "analog intrusion denial" state, which prevents an analog line from barging into an existing DECT call if barge-in is provisioned to be disabled by the service provider. Refer to the [HDV] for more information on this state.

Table 1 - DECT to NCS Event Mapping

NCS Event Code	Description	DECT Stimulus from PP Required to Generate Event	Analog Interface Stimulus Required to Generate Event
0-9,*,#,A,B,C,D	DTMF tones	<<KEYPAD>> or <<MULTI-KEYPAD>> information element containing DTMF digit information.	DTMF digits received are processed normally unless received when the client is in the analog intrusion denial state.
NCS Event Code	Description	DECT Stimulus from PP Required to Generate Event	Analog Interface Stimulus Required to Generate Event
ft	Fax tone	N/A	Fax tone event generation occurs normally unless the client is in the analog intrusion denial state.
hd	Off-hook transition	CC-SETUP message for an outgoing call request received when the current hook status of the client is on-hook. CC-CONNECT message received for a call initiated by the FP due to an incoming call from the network and the current hook status is on-hook.	An off-hook event is generated only when an analog phone goes off-hook and the current hook status of the client is on-hook.
hf	Flash hook	<<KEYPAD>> or <<MULTI-KEYPAD>> information element containing an element with a value of 15H indicating that the "register recall" key has been pressed on the PP.	When a flash hook is detected at the analog interface, the flash hook event is generated only if the client is not in the analog intrusion denial state.

NCS Event Code	Description	DECT Stimulus from PP Required to Generate Event	Analog Interface Stimulus Required to Generate Event
hu	On-hook transition	CC-RELEASE or CC-RELEASE-COM message received from the last PP involved in the call over the network and the hook status of the associated analog interface is either on-hook or in the analog intrusion denial state.	An on-hook event is generated only if there is no PP involved in a network call, i.e., all DECT calls over the air have been released that may have been involved in a network call. Note that other calls may exist over the air for the purpose of intercom.
L	DTMF long duration	Detected two seconds after receiving <<KEYPAD>> or <<MULTI-KEYPAD>> information element containing DTMF digit information with control code 16H without receiving an indication that the digit had stopped. Note that support for control code 16H is optional.	DTMF digits received are processed normally unless received when the client is in the analog intrusion denial state. Therefore, DTMF long duration is not detected in this case.
ld	Long duration connection	N/A	Unaffected by DECT
ma	Media start	N/A	Unaffected by DECT
mt	Modem tones	N/A	Modem tone event generation occurs normally unless the client is in the analog intrusion denial state.
oc	Operation complete	N/A	Unaffected by DECT
of	Operation failure	N/A	Unaffected by DECT
t	Timer	Critical and partial dialing timeout is detected normally by the client. Timers are set when digits are received in a <<KEYPAD>> or <<MULTI-KEYPAD>> information element. Receipt of the <<SENDING-COMPLETE>> information element also generates this event.	DTMF digits received are processed normally unless received when the client is in the analog intrusion denial state. Therefore, critical and partial dialing are not detected at the analog interface in this case.
TDD	Telecomm Devices for the Deaf (TDD) tones	N/A	TDD tone event generation occurs normally unless the client is in the analog intrusion denial state.
X	DTMF tones wildcard	<<KEYPAD>> or <<MULTI-KEYPAD>> information element containing DTMF digit information [0-9].	DTMF digits received are processed normally unless received when the client is in the analog intrusion denial state.

6.2.1.1 DTMF Tones (0-9, *, #, A, B, C, D)

The FP MUST detect DTMF tones as specified in the DTMF Digit Processing procedures of [HDV].

The client MUST detect DTMF tones from the FP as specified in the DTMF Digit Processing procedures of [HDV]. The client MUST generate DTMF tone events accordingly per [NCS].

6.2.1.2 Fax Tones (ft)

Fax does not apply to the DECT air interface. Fax tone detection on the analog line is defined in [NCS].

6.2.1.3 Off-hook (hd)

The FP MUST detect off-hook transitions as specified in the Hook Status procedures of [HDV].

The client MUST detect off-hook transition status as specified in the Hook Status procedures of [HDV]. The client MUST generate an off-hook transition event per [NCS] when the client hook status transitions to off-hook.

6.2.1.4 Flash hook (hf)

The FP MUST detect flash hook indications from the PP as specified in the Hook Flash procedures of [HDV].

The client MUST generate a flash hook event per [NCS] when the FP detects a hook flash indication as specified in the Hook Flash procedures of [HDV].

The client MUST generate a flash hook event per [NCS] when hook flash is detected at the analog interface, but only if not in the analog intrusion denial state.

The client MUST NOT generate a flash hook event per [NCS] when a flash hook is detected at the analog interface while in the analog intrusion denial state.

6.2.1.5 On-hook (hu)

The FP MUST detect on-hook transitions as specified in the Hook Status procedures of [HDV].

The client MUST detect on-hook transition status as specified in the Hook Status procedures of [HDV]. The client MUST generate an on-hook transition event per [NCS] when the client hook status transitions to on-hook.

6.2.1.6 DTMF Long Duration

If the FP supports the "go to DTMF (infinite tone length)" N22 feature as defined in [EN 300 444], then the client MUST generate a DTMF Long Duration event two seconds after the FP receives a valid DECT call control message containing either the <<KEYPAD>> or <<MULTI-KEYPAD>> information element with a control code of 16H and DTMF digit information if a subsequent DECT call control message with the <<KEYPAD>> or <<MULTI-KEYPAD>> information element had not been received indicating that the digit had stopped as defined in the procedures for Sending Keypad Information in [EN 300 444].

6.2.1.7 Long Duration Connection

This Long Duration Connection event is not affected by DECT and is generated and processed normally as defined in [NCS].

6.2.1.8 Media Start

The Media Start event is not affected by DECT and is generated and processed normally as defined in [NCS].

6.2.1.9 Modem Tones (mt)

Modem tones do not apply to the DECT air interface. Modem tone detection on the analog line is defined in [NCS].

6.2.1.10 Operation Complete

The Operation Complete event is generated normally when a timeout ring or tone signal is completed. For Open Switch Interval (OSI), the client MUST generate the Operation Complete event if the FP detects that a PP involved in the call remains off-hook (i.e., CC-RELEASE-COM message has not yet been received) after the defined timeout (default is 900 ms).

6.2.1.11 Operation Failure

The Operation Failure event is not affected by DECT and is generated and processed normally per [NCS].

6.2.1.12 Timer (t)

Digit events are generated as described in DTMF Digit Processing procedures of [HDV]. The timing for critical and partial dialing is based on the time the digit events are generated. When a timeout occurs, the client MUST generate the Timer event.

6.2.1.13 Telecom Devices for the Deaf Tones (TDD)

TDD does not apply to the DECT air interface. TDD procedures on the analog line are defined in [NCS].

6.2.1.14 DTMF Tones Wildcard (X)

The client MUST generate digit events as described in DTMF Digit Processing procedures in [HDV]. Mapping a digit to the DTMF Tones Wildcard event (e.g., within a digit map) occurs based on the DTMF tone events generated.

6.2.2 NCS Line Package Signal Mapping to DECT

This section describes the NCS signals that may be requested by the Call Agent, and the effect on the DECT interface. All signals applicable to the analog interface are applied according to [NCS] unless specified otherwise. The FP MUST generate signals and tones as defined in [NCS] and send them to the PPs as described in the subsections that follow Table 2, and in the [HDV] specification. The client MUST generate signals and tones as defined in [NCS] and apply them to the analog line as described in the subsections that follow the table below and in

[HDV]. Table 2 provides an informative summary of NCS signal mapping that is normatively described in the following subsections. The signals are provisioned per PacketCable provisioning specifications for E-MTAs.

Table 2 - DECT to NCS Signal Mapping

NCS Signal Code	Description	Effect on DECT Interface	Effect on Analog Interface
0-9, *, #, A, B, C, D	DTMF tones	The tone is generated on the FP and inserted into the media stream to all PPs involved in the network call.	The tone is generated onto the analog interface only if the client is not in the analog intrusion denial state and the hook status of the analog interface is off-hook.
bz	Busy tone	The tone is generated on the FP and inserted into the media stream to all PPs involved in the network call.	The tone is generated onto the analog interface only if the client is not in the analog intrusion denial state and the hook status of the analog interface is off-hook.
cf	Confirmation tone	The tone is generated on the FP and inserted into the media stream to all PPs involved in the network call.	The tone is generated onto the analog interface only if the client is not in the analog intrusion denial state and the hook status of the analog interface is off-hook.
ci(ti, nu, na)	Caller Id	The following information elements are included in a valid DECT call control message to all registered PPs. The number is included in the <<CALLING-PARTY-NUMBER>> information element. The name is included in the <<CALLING-PARTY-NAME>> information element. The time field is delivered in the <<TIME-DATE>> information element of the IWU-INFO message. Note that calling party number, name and time-date can be delivered in a single IWU-INFO message. When the caller ID time is not available, the calling party number and name can be delivered in other valid messages such as a CC-SETUP.	Caller ID is delivered normally only if the client is not in the analog intrusion denial state and the hook status of the analog interface is off-hook.
dl	Dial tone	The tone is generated on the FP and inserted into the media stream to all PPs involved in the network call.	The tone is generated onto the analog interface only if the client is not in the analog intrusion denial state and the hook status of the analog interface is off-hook.
mwi	Message waiting indicator	The tone is generated on the FP and inserted into the media stream to all PPs involved in the network call.	The tone is generated onto the analog interface only if the client is not in the analog intrusion denial state and the hook status of the analog interface is off-hook.
osi	Open interval	The FP sends a CC-RELEASE message to all PPs involved in the network call.	Unaffected by DECT.
ot	Off-hook warning tone	The tone is generated on the FP and inserted into the media stream to all PPs involved in the call.	The tone is generated onto the analog interface only if the client is not in the analog intrusion denial state and the hook status of the analog interface is off-hook.
r0, r1, r2, r3, r4, r5, r6 or r7	Distinctive ringing (0..7)	The FP sends a valid DECT call control message to all available PPs with the <<SIGNAL>> information element included and set to "ring on continuous". The FP subsequently controls the ring cadence by sending additional DECT call control messages containing the <<SIGNAL>> information element set to either "ring on continuous" or "ring off". If the user does not answer the call on a PP then the DECT call is released against that PP when either the ring signal times out or the call is answered using another PP or analog phone.	Unaffected by DECT.

NCS Signal Code	Description	Effect on DECT Interface	Effect on Analog Interface
rg	Ringling	The FP sends a valid DECT call control message to all available PPs with the <<SIGNAL>> information element included and set to "ring on continuous". The FP subsequently controls the ring cadence by sending additional DECT call control messages containing the <<SIGNAL>> information element set to either "ring on continuous" or "ring off". If the user does not answer the call on a PP then the DECT call is released against that PP when either the ring signal times out or the call is answered using another PP or analog phone	Unaffected by DECT.
ro	Reorder tone	The tone is generated on the FP and inserted into the media stream to all PPs involved in the call.	The tone is generated onto the analog interface only if the client is not in the analog intrusion denial state and the hook status of the analog interface is off-hook.
rs	Ringsplash	The FP sends a valid DECT call control message to all available PPs with the <<SIGNAL>> information element included and set to "ring on continuous". The FP subsequently controls the ring cadence by sending additional DECT call control messages containing the <<SIGNAL>> information element set to either "ring on continuous" or "ring off". If the user does not answer the call on a PP then the DECT call is released against that PP when either the ring signal times out or the call is answered using another PP or analog phone	Unaffected by DECT
rt	Ring back tone	When requested to be applied on the client, the tone is generated on the FP and inserted into the media stream to all PPs involved in the call. When requested to be applied over the connection, it is unaffected by DECT.	When requested to be applied on the client, the tone is generated onto the analog interface only if the client is not in the analog intrusion denial state and the hook status of the analog interface is off-hook.
sl	Stutter dial tone	The tone is generated on the FP and inserted into the media stream to all PPs involved in the call.	The tone is generated onto the analog interface only if the client is not in the analog intrusion denial state and the hook status of the analog interface is off-hook.
vmwi	Visual message waiting indicator	The FP sends a FACILITY message with the <<EVENTS-NOTIFICATION>> information element with the event type set to "message waiting".	Unaffected by DECT.
wt1, wt2, wt3, wt4	Call waiting tones	The tone is generated on the FP and inserted into the media stream to all PPs involved in the call.	The tone is generated onto the analog interface only if the client is not in the analog intrusion denial state and the hook status of the analog interface is off-hook.

6.2.2.1 Open Switch Interval (osi)

When requested, OSI is applied to the analog interface normally, even if the client is in the analog intrusion denial state.

If a PP is involved in a call not serviced locally by the FP, then the FP MUST release the call by following the procedures defined for Normal Call Release and Abnormal Call Release in [EN 300 444].

6.2.2.2 Visual Message Waiting Indicator (vmwi)

As described in the Visual Message Waiting Indicator section of [HDV], the FP transmits VMWI information to each successfully registered PP by sending a FACILITY message with the <<EVENTS-NOTIFICATION>> information element containing the event type set to "message waiting", the sub-type set to "voice message", and the event multiplicity set to represent the number of new messages. For NCS the Call Agent will only provide an

indication that messages are waiting, but not the specific number of messages. As such, the FP MUST set the event multiplicity to indicate one new message for VMWI on and zero new messages for VMWI off.

6.2.3 Other NCS Packages

The FAX and VoIP Metrics packages are unaffected by DECT. T.38 Fax Relay is applicable only to the analog interface. VoIP metrics are gathered independent of the DECT air interface. Refer to the [HDV] for VoIP metric requirements

6.2.4 Auditing

The response to NCS audit messages (AUEP and AUCX) is unaffected by DECT. When the endpoint's capabilities are audited, the endpoint MUST NOT include Codecs that are only supported over the DECT air interface. The endpoint MUST include only Codecs supported over the PacketCable network (see Section 6.2.6).

6.2.5 NCS Connection Requests

Connections are created on a client for various purposes: external call setup, local endpoint testing, and media replication. The receipt of a Create Connection command does not in itself initiate call setup over the DECT interface by the FP. Only signal requests that may be contained within a connection-oriented command, or sent independently in a Request for Notification, are triggers to the FP to initiate call setup. The generation of some signals requires the FP to set up a call (e.g., ringing). When the signal is complete and there are no other pending signals requiring DECT call setup, the hook status of the client determines if the DECT call will be released. If the hook status is off-hook, then the FP MUST release the call to the PPs still on-hook. If the hook status is off-hook, then the FP MUST NOT release the call to all PPs that are off-hook. Note, however, that the application of the OSI signal does release the call as defined in Section 6.2.2.1.

If the hook status is on-hook, then the release depends on the connection status of the client at the moment the signal completes. If no connections exist, then the FP MUST release the call. If one or more connections exist, then the call is released based on the purpose of each connection. For the purpose of DECT a connection in either the NETWTEST or NETWLOOP mode is used for local endpoint testing. A connection in the REPLCATE mode is used for media replication. All other connection modes indicate that the connection is used for an external call. Neither local endpoint testing nor media replication requires the DECT call to be set up. Connections set up for the purpose of local endpoint testing do not involve the DECT interface since media received from the network is looped back by the client before reaching the air interface. Connections set up for the purpose of media replication also do not directly influence the DECT interface. If a network-based call exists with the DECT interface while another connection exists on the client or media replication, then media received over the DECT air interface MUST be forwarded onto the media replication connection, the same way that occurs with the analog interface. Only connections that exist for an external call require the DECT call to be set up. Therefore, if no connections exist on the client for the purpose of external calls at the time signal generation is complete, then the FP MUST release the call. Otherwise, the FP MUST maintain the call as long as an error condition does not exist allowing the FP to release the call as described in the Abnormal Call Release procedures of [EN 300 444].

If the call is maintained as described above, then call release again depends on the hook status of the client. For off-hook client the call is released only when specifically requested by the Call Agent via the OSI signal. In this case the FP MUST release the call regardless of the connection status of the client. For on-hook endpoints, the FP MUST release the call upon receipt of a Modify Connection (or application of an embedded modify connection) command resulting in all connections being modified for the purpose of local endpoint testing or media replication, i.e., no other connections exist for the purpose of an external call.

NCS Delete Connection commands may lead the FP to terminate calls to the PPs. The FP MUST release a call upon receipt of a Delete Connection command when the endpoint hook status is on-hook when the resulting connection status is such that no connection exists for the purpose of an external call. The FP does not release a call over the air if the endpoint hook status is off-hook and a Delete Connection command is received.

Note that internal DECT calls are not impacted by NCS Connection Request or NCS Delete Connection requests.

6.2.6 CODECS

The PacketCable 1.5 client (NCS endpoint) MUST support G.722 and other mandatory codecs (such as G.711) specified in [CODEC1.5] for negotiation and use on the PacketCable network. The PacketCable 1.5 client (NCS endpoint) MAY support optional codecs specified in [CODEC1.5] for negotiation and use on the PacketCable

network. Refer to the [HDV] spec for codec requirements on the DECT air interface. The PacketCable 1.5 client (NCS endpoint) MUST use SDP media stream line (m=) for indicating negotiated or supported codecs. Multiple codecs in the m= line means the PacketCable 1.5 client (NCS endpoint) MUST be ready to receive media packets from any of the negotiated codecs. As well, the PacketCable 1.5 (NCS endpoint) client may send media packets from any of the negotiated codecs and switch between them as required.

During the establishment of a three-way call (3WC), the Call Agent MUST keep the codec for the existing two-party call unchanged, regardless of the selected codec for the second call with the third party.

Appendix I Example Call Flows (Informative)

This appendix is informative; if discrepancies exist between the sample message flows and normative requirements contained in other sections of this document, the normative requirements supersede the informative flows.

I.1 Call Setup – Originator – Overlap Sending

#	DECT PP	DECT FP / E-MTA	Call Agent
1	CC-SETUP	->	
2		<- CC-SETUP-ACK(PI=8)	
3	<--- Media Flows (DECT) --->		
4		NTFY(hd)	->
5			<- 200
6			<- RQNT(dl,digits)
7			200 ->
8	CC-INFO(digits)	->	
9		NTFY(digits)	->
10		<- CC-CALL-PROC	
11			<- 200
12			<- RQNT(rt,hu)
13		<- CC-CALL-ALERTING	
14			200 ->
15			<- CRCX
16		200(sdp-o)	->
17			<- MDCX(sdp-t)
18			200 ->
19	<--- Media Flows (DECT & NCS) --->		
20			<- RQNT(stop rt)
21		<- CC-CONNECT	
22			200 ->

Assumptions and background information:

- The request to play dial tone and collect digits is received before the request to create a connection.
- Dialing is performed after going off-hook.
- The PP is capable of using G.722, PCMU, and G.726, and has reported its capabilities to the FP during registration.
- The PP provides the entire list of Codecs in the <<CODEC-LIST>> IE of the CC-SETUP message.
- The configured Codec list is set to "G.722, PCMU".

Step 1:

The user goes off-hook on the PP by pressing the talk button. The PP sends a CC-SETUP message to the originating FT. The digits will be delivered in subsequent CC-INFO messages, one or more digits at a time.

The PP provides a list of Codecs in the <<CODEC-LIST>> IE (G.722, PCMU, G.726). If it was not provided, then the default list provided during handset registration would be used as the endpoint's capabilities.

Step 2:

The originating FP sends a CC-SETUP-ACK message to the PP with instructions to activate the U-plane by including the <<PROGRESS-INDICATOR>> IE with a value of 8. This is in response to the FP receiving a valid CC-SETUP message for an outbound call.

The CC-SETUP-ACK message is used to indicate that the FP needs more digits to process the call, i.e., it is an indication that Overlap Sending is in use.

The FP includes the <<CODEC-LIST>> IE set to "G.722" since the PP is capable of G.722 and the configured Codec list indicates that G.722 is the preferred Codec.

Step 3:

The PP connects the U-plane to enable media over the DECT air interface. This is necessary to play tones from the FP to the PP. G.722 is enabled over the DECT air interface.

Step 4:

An off-hook event is generated and notified to the Call Agent. The off-hook event is generated in response to the receipt of the CC-SETUP message above. The off-hook event is processed upon receipt of the SETUP. The call flow simply indicates that the CC-SETUP-ACK message is also triggered in response to the CC-SETUP message and it not delayed by messaging over the network. In other words, the FP does not wait for an acknowledgement to the following Notify triggered before sending the CC-SETUP-ACK.

```
NTFY 6 aaln/1@ep-o.sample.com MGCP 1.0 NCS 1.0
X: 36
O: hd
```

Step 5:

The Call Agent acknowledges the NTFY.

```
200 6 OK
```

Step 6:

The Call Agent sends an RQNT to play dial tone and request digits according to the supplied digit map.

```
RQNT 41 aaln/1@ep-o.sample.com MGCP 1.0 NCS 1.0
X: 37
D: (xxxxxxx|x.T#)
R: hu, 0-9*#T(D)
S: dl
```

Step 7:

The originating FP acknowledges the RQNT. Dial tone is generated by the FP toward the PP.

```
200 41 OK
```

Step 8:

Digits are sent in CC-INFO messages one or more at a time. Digits are processed according to the last notification request received from the Call Agent, e.g., they may be processed according to a supplied digit map.

An operation complete event is generated if the dial tone times out before the first CC-INFO message is received with digit information. Otherwise, dial tone is stopped upon receipt of the first CC-INFO message containing digit information (unless otherwise instructed by the Call Agent to keep the signal alive). Partial dialing and critical dialing detection is handled in the FP as specified in NCS.

Step 9:

Assuming that digits are processed according to a supplied digit map, the digits collected trigger a match. The originating FP sends a NTFY to the Call Agent.

NTFY 7 aaln/1@ep-o.sample.com MGCP 1.0 NCS 1.0
X: 37
O: 5,5,5,1,2,1,2

If the user did not provide enough digits to map to a particular element of the digit map, the dialing timeout (T) event generated by the FP will trigger notification. This will be a partial dial indication to the Call Agent.

Note that the user may have provided additional digits. These events are simply processed according to the rules of NCS. For example, they may be quarantined, and then later processed according to a new request for notification.

Step 10:

The originating FP may send a CC-CALL-PROC message to the PP indicating that call setup is in progress. This is an indication to the PP that all information required to set up the call has been received. Specifically, in this example, a match has been made against the supplied digit map.

Step 11:

The Call Agent acknowledges the NTFY.

200 7 OK

Step 12:

The Call Agent sends an RQNT to play ring back tone and requests notification of on-hook.

RQNT 42 aaln/1@ep-o.sample.com MGCP 1.0 NCS 1.0
X: 38
R: hu
S: rt

Step 13:

The originating FP sends a CC-CALL-ALERTING message to the PP and also generates local ring back tone which is transmitted in the media sent from the FP to the PP.

Step 14:

EP-o acknowledges the RQNT.

200 42 OK

Step 15:

The Call Agent creates a connection on the originating FP.

CRCX 43 aaln/1@ep-o.sample.com MGCP 1.0 NCS 1.0
C: 51005E4E0003A9ED1700
M: inactive
L: mp:20;20, a:G722;PCMU

Step 16:

The originating FP creates the connection, acknowledges the CRCX and returns its SDP.

200 43 OK
I: 3

<sdp-o (G722,PCMU)>

Step 17:

After the terminator answers, the Call Agent modifies the connection on the originating FP to send-receive.

MDCX 44 aaln/1@ep-o.sample.com MGCP 1.0 NCS 1.0
C: 51005E4E0003A9ED1700
I: 3

M: sendrecv

<sdp-t (G722,PCMU)>

Step 18:

The originating FP acknowledges the MDCX.

200 44 OK

Step 19:

Media flows over the DECT air interface as well as over the network.

Step 20:

The Call Agent sends an RQNT to the originating FP to stop local ring back tone.

RQNT 45 aaln/1@ep-o.sample.com MGCP 1.0 NCS 1.0
 X: 39
 R: hu

Step 21:

The originating FP sends a CC-CONNECT message to the PP. The FP stops local ring back tone.

Note at this point that the call has been established. If local ring back tone had not been applied at Step 10, then the call would be considered established only after the remote SDP is obtained and the originating FP is expected to send and/or receive media.

Step 22:

The originating FP acknowledges the RQNT.

200 45 OK

I.2 Call Setup – Terminator – CRCX before RG Request

#	DECT PP	DECT FP / E-MTA	Call Agent
1			<- CRCX(sdp-o)
2		200(sdp-t)	->
3			<- RQNT(rg,ci)
4		200	->
5	<- CC-SETUP(each PP)		
6	CC-ALERTING(each PP)	->	
7	<- IWU-INFO(each PP)		
8	<- CC-INFO(each PP)		
9	CC_CONNECT(answer PP)	->	
10	<- CC-CONNECT-ACK		
11	<--- Media Flows (DECT) --->		
12	<- CC-RELEASE(other PPs)		
13	CC-RELEASE-COM(others)	->	
14		NTFY(hd)	->
15		<- 200	
16		<- RQNT(hu)	
17		200	->
18		<- MDCX(sendrecv)	
19		200	->
20	<--- Media Flows (DECT & NCS) --->		

Assumptions / background information:

- A create connection message is received before the endpoint is requested to ring the phone, or the CRCX contains a request to ring.
- Multiple PPs are available.
- The configured Codec list is "G.722, PCMU".

Step 1:

The Call Agent creates a connection on the terminating FP.

```
CRCX 97 aaln/1@ep-t.sample.com MGCP 1.0 NCS 1.0
C: 51005E4E0003A9ED1701
M: inactive
L: mp:20;20, a:G722;PCMU

<sdp-o(G722,PCMU)>
```

Step 2:

The terminating FP creates the connection, acknowledges the CRCX and returns its SDP. Note that the PPs are not alerted at this point. The connection may be needed for something other than an inbound call, e.g., loopback testing.

```
200 97 OK
I: 4

<sdp-t (G722,PCMU)>
```

Step 3:

The Call Agent sends an RQNT to ring the phone and deliver caller ID.

```
RQNT 96 aaln/1@ep-t.sample.com MGCP 1.0 NCS 1.0
X: 88
R: hd
S: rg, ci(07/28/09/51, 8675309, Jenny)
```

Step 4:

The terminating FP acknowledges the RQNT.

```
200 96 OK
```

Step 5:

The terminating FP sends a CC-SETUP message to each PP registered with the FP and includes the <<CODEC-LIST>> IE set to "G.722" since G.722 was negotiated over the network and is the preferred Codec provided in the configured Codec list.

The <<SIGNAL>> IE is included and set to "ring on – continuous" to begin alerting. The <<CALLING-PARTY-NUMBER>> IE is included and set to the Caller ID number from the Caller ID request and the <<CALLING-PARTY-NAME>> IE is included and set to the Caller ID name from the Caller ID request.

Step 6:

Each PP being alerted replies with a CC-ALERTING message indicating that the CC-SETUP message has been successfully processed. The message may include the <<CODEC-LIST>> IE indicating the use of G.722, but also may be provided later in the CC-CONNECT.

Step 7:

The FP sends IWU-INFO messages to each registered PP with the <<TIME-DATE>> IE set according to the time field of the Caller ID request.

Step 8:

The terminating FP sends CC-INFO messages to each PP registered with the FP and includes the <<SIGNAL>> IE set to either "ring on – continuous" or "ring off" to control the ring cadence.

Step 9:

A user goes off-hook on a PP. The PP sends a CC-CONNECT message as a result.

Step 10:

The terminating FP sends a CC-CONNECT-ACK message to the PP indicating that the call is established. Note that this message is sent before the Call Agent modifies the connection to SENDRECV. This is to insure that the U-plane is connected before that occurs.

Step 11:

The PP connects the U-plane to enable media over the DECT air interface.

Step 12:

The terminating FP sends CC-RELEASE messages to the remaining PPs that were successfully alerted.

Step 13:

Each PP responds with CC-RELEASE-COM.

Step 14:

The terminating FP generates an off-hook event which is notified to the Call Agent. Note that this event is generated in response to the receipt of the CC-CONNECT message and is processed at that time.

```
NTFY 8 aaln/1@ep-t.sample.com MGCP 1.0 NCS 1.0
X: 88
O: hd
```

Step 15:

The Call Agent acknowledges the NTFY.

```
200 8 OK
```

Step 16:

The Call Agent sends an RQNT to notify on-hook.

```
RQNT 98 aaln/1@ep-t.sample.com MGCP 1.0 NCS 1.0
X: 89
R: hu
```

Step 17:

The terminating FP acknowledges the RQNT.

```
200 98 OK
```

Step 18:

The Call Agent modifies the connection on the terminating FP to send-receive.

```
MDCX 99 aaln/1@ep-t.sample.com MGCP 1.0 NCS 1.0
C: 51005E4E0003A9ED1701
I: 4
M: sendrecv
```

Step 19:

The terminating FP acknowledges the MDCX.

```
200 99 OK
```

Step 20:

Media flows over the DECT air interface as well as over the network.

I.3 Call Teardown – Local Endpoint Initiated

#	DECT PP	DECT FP / E-MTA	Call Agent
1	CC-RELEASE	->	
2		<- CC-RELEASE-COM	
3		NTFY(hu)	->
4			<- 200
5			<- RQNT(hd)
6			200 ->
7			<- DLCX
8			250 ->

Assumptions / background information:

- An active call is in progress with a single NCS connection.
- The local user hangs up first.

Step 1:

The local user goes on-hook. The PP sends a CC-RELEASE message.

Step 2:

The FP sends a CC-RELEASE-COM message to the PP.

Step 3:

An on-hook event is generated by the endpoint and notified to the Call Agent.

```
NTFY 120 aaln/1@ep.sample.com MGCP 1.0 NCS 1.0
X: 180
O: hu
```

Step 4:

The Call Agent acknowledges the NTFY.

```
200 120 OK
```

Step 5:

The Call Agent sends an RQNT to notify off-hook.

```
RQNT 900 aaln/1@ep.sample.com MGCP 1.0 NCS 1.0
X: 181
R: hd
```

Step 6:

The endpoint acknowledges the RQNT.

```
200 900 OK
```

Step 7:

The Call Agent sends a DLCX to delete the connection.

```
DLCX 901 aaln/1@ep.sample.com MGCP 1.0 NCS 1.0
C : 51005E4E0003A9ED1701
I: 3
```

Step 8:

The endpoint deletes the connection and sends an acknowledgement.

```
250 901 Connection Deleted
P: PS=110, OS=110, PR=110, OR=110, PL=0, JI=0, LA=0, PC/RCS=110, PC/ROS=110, PC/RPL=0,
PC/RJI=0
```

I.4 Call Teardown – Remote Endpoint Initiated

#	DECT PP	DECT FP / E-MTA	Call Agent
1			<- DLCX
2			250 ->
3			<- RQNT(osi)
4			200 ->
5	<- CC-RELEASE		
6	CC-RELEASE-COM	->	
7		NTFY(hu)	->
8		<- 200	
9		<- RQNT(hd)	
10		200	->

Assumptions / background information:

- An active call is in progress with a single NCS connection.
- The far end user hangs up first.

Step 1:

The Call Agent sends a DLCX to delete the connection.

```
DLCX 1000 aaln/1@ep.sample.com MGCP 1.0 NCS 1.0
C : 51005E4E0003A9ED1701
I: 3
```

Step 2:

The endpoint deletes the connection and sends an acknowledgement.

```
250 1000 Connection Deleted
P: PS=110, OS=110, PR=110, OR=110, PL=0, JI=0, LA=0, PC/RCS=110, PC/ROS=110, PC/RPL=0,
PC/RJI=0
```

Step 3:

The Call Agent sends an RQNT to apply the OSI signal indicating that the remote user hung up.

```
RQNT 1001 aaln/1@ep.sample.com MGCP 1.0 NCS 1.0
X: 281
R: hd
S: osi
```

Note that the call is only released by the FP when this request is made. Otherwise, the call will be released by the PP after the local user hangs up.

Step 4:

The endpoint acknowledges the RQNT.

```
200 1001 OK
```

Step 5:

The endpoint sends a CC-RELEASE message to the PP.

Step: 6:

The PP sends a CC-RELEASE-COM message.

Step: 7:

An on-hook event is generated by the endpoint and notified to the Call Agent.

```
NTFY 220 aaln/1@ep.sample.com MGCP 1.0 NCS 1.0
X: 281
O: hu
```

Step 8:

The Call Agent acknowledges the NTFY.

```
200 220 OK
Step 9:
```

The Call Agent sends an RQNT to notify off-hook.

```
RQNT 1002 aaln/1@ep.sample.com MGCP 1.0 NCS 1.0
X: 282
R: hd
```

Step 10:

The endpoint acknowledges the RQNT.

```
200 1002 OK
```

I.5 Call Waiting – Single Connection (HF → DLCX → CRCX)

#	DECT PP	DECT FP / E-MTA	Call Agent
1			<- RQNT(wt1,ci)
2			200 ->
3		<- CC-INFO(cid name & #)	
4		<- IWU-INFO(cid time)	
5	CC-INFO(keypad=15H)	->	
6		NTFY(hf)	->
7		<- 200	
8		<- RQNT(hf,hu)	
9		200 ->	
10		<- DLCX	
11		250 ->	
12		<- CRCX(sdp-o)	
13		200(sdp-t)	->
14		<- Change Codec	
15	Codec Changed	->	

Assumptions / background information:

- An active call is in progress with a single NCS connection.
- The register recall button is used to accept the incoming call.

Step 1:

The call agent issues a request for notification to play the call waiting tone and present caller ID information.

```
RQNT 100 aaln/1@ep.sample.com MGCP 1.0 NCS 1.0
X: 50
S: wt1, ci(07/28/09/51, 8675309, Jenny)
R: hf, hu
```

Step 2:

The endpoint acknowledges the RQNT.

```
200 100 OK
```

Step 3:

The FP sends a CC-INFO message to the PP with a request to display caller ID. The <<CALLING-PARTY-NUMBER>> IE is included and set to the Caller ID number from the Caller ID request and the <<CALLING-PARTY-NAME>> IE is included and set to the Caller ID name from the Caller ID request.

The FP generates the requested call waiting tone. Note that the CC-INFO message is sent in parallel with the application of the call waiting tone. There is no need to wait until the first iteration of the call waiting tone is complete before sending the CC-INFO message.

Step 4:

The FP sends an IWU-INFO message to the PP with the <<TIME-DATE>> IE set according to the time field of the Caller ID request.

Step 5:

The user presses the flash (i.e., register recall) key. The PP sends a CC-INFO message containing the <<KEYPAD>> or <<MULTI-KEYPAD>> IE with the control code set to 15H.

Step 6:

The FP generates a flash hook event resulting in a notification to the Call Agent.

```
NTFY 200 aaln/1@ep.sample.com MGCP 1.0 NCS 1.0
X: 50
O: hf
```

Step 7:

The Call Agent acknowledges the NTFY.

```
200 200 OK
```

Step 8:

The Call Agent sends a new request for notification to notify the flash hook event.

```
RQNT 101 aaln/1@ep.sample.com MGCP 1.0 NCS 1.0
X: 51
R: hf, hu
```

Step 9:

The endpoint acknowledges the RQNT.

```
200 101 OK
```

Step 10:

The Call Agent deletes the connection. This is the only connection on the endpoint. The endpoint does not issue a CC-RELEASE message to the PP since the Call Agent has not requested the OSI signal.

```
DLCX 102 aaln/1@ep.sample.com MGCP 1.0 NCS 1.0
C : 51005E4E0003A9ED1701
I: 3
```

Step 11:

The endpoint acknowledges the DLCX.

```
250 102 Connection Deleted
P: PS=110, OS=110, PR=110, OR=110, PL=0, JI=0, LA=0, PC/RCS=110, PC/ROS=110, PC/RPL=0,
PC/RJI=0
```

Step 12:

The Call Agent creates a new connection with SDP from the waiting remote endpoint.

```
CRCX 43 aaln/1@ep-o.sample.com MGCP 1.0 NCS 1.0
C: 51005E4E0003A9ED1700
M: inactive
L: mp:20;20, a:G722;PCMU
<sdp-o>
```

Step 13:

The endpoint acknowledges the CRCX

```
200 43 OK
I: 4
<sdp-t (G722,PCMU)>
```

Step 14:

The endpoint requests a Codec change if necessary.

The DECT air requirements may differ between the two calls (e.g., one is narrowband using full slot and the other is wideband or G.711 using long slot). In this scenario, the FP may switch from one to the other each time the user flashes. Alternatively, the FP may detect this scenario and maintain long slot over the DECT air interface to avoid service interruption.

Step 15:

The change Codec procedure is completed.

I.6 Call Teardown – DLCX Delayed by Call Agent

#	DECT PP	DECT FP / E-MTA	Call Agent
1	CC-RELEASE	->	
2		<- CC-RELEASE-COM	
3			NTFY(hu) ->
4			<- 200
5			<- RQNT(hd)
6			200 ->
7			<- RQNT(rg)
8			200 ->
9		<- CC-SETUP(alert on)	
10	CC-ALERTING	->	
11		<- CC-INFO(alert off/on)	
12	CC_CONNECT	->	
13		<- CC-CONNECT-ACK	
14		<--- Media Flows (DECT & NCS) --->	
15			NTFY(hd) ->
16			<- 200
17			<- RQNT(hu)
18			200 ->

Assumptions / background information:

- An active E911 call is in progress with a single NCS connection.
- The local E911 user hangs up; however, the E911 operator does not release the call. The operator alerts the local user to re-establish the call.

Step 1:

The local user goes on-hook. The PP sends a CC-RELEASE message.

Step 2:

The endpoint sends a CC-RELEASE-COM message to the PP.

Step 3:

An on-hook event is generated by the FP and notified to the Call Agent.

```

NTFY 120 aaln/1@ep.sample.com MGCP 1.0 NCS 1.0
X: 180
O: hu
    
```

Step 4:

The Call Agent acknowledges the NTFY.

200 120 OK

Step 5:

The Call Agent sends an RQNT to notify off-hook.

RQNT 900 aaln/1@ep.sample.com MGCP 1.0 NCS 1.0
 X: 181
 R: hd

Step 6:

The endpoint acknowledges the RQNT.

200 900 OK

Step 7:

The Call Agent does not send a DLCX to tear down the call. Instead an RQNT is sent to alert the user as per the E911 operator's request.

RQNT 901 aaln/1@ep.sample.com MGCP 1.0 NCS 1.0
 X: 182
 R: hd
 S: rg

Step 8:

The endpoint acknowledges the RQNT.

200 901 OK

The remaining steps are similar to those in call flow #2 "Call Setup – Terminator – CRCX before RG Request" since a connection already exists on the endpoint at this point.

I.7 Call Forwarding Variable – Usage Example

#	DECT PP	DECT FP / E-MTA	Call Agent
1			<- RQNT(rs,ci)
2			200 ->
3		<- CC-SETUP(alert on,cid)	
4	CC-ALERTING	->	
5		<- IWU-INFO(cid time)	
6		<- CC-INFO(alert off/on)	
7		<- CC-RELEASE	
8	CC-RELEASE-COM	->	

Assumptions / background information:

- The local user has Call Forwarding enabled.
- An incoming call is attempted to the local user.
- The Call Agent alerts the local user before forwarding the call and also provides Caller ID information.

Step 1:

The Call Agent sends an RQNT to ring the phone and play Caller ID.

```
RQNT 96 aaln/1@ep-t.sample.com MGCP 1.0 NCS 1.0
X: 88
R: hd
S: rs, ci(08/11/09/51, 8675309, Jenny)
```

Step 2:

The terminating FP acknowledges the RQNT.

```
200 96 OK
```

Step 3:

The terminating FP sends a CC-SETUP message to each registered PP instructing it to start ringing using the <<SIGNAL>> IE set to "alerting on – continuous". The <<CALLING-PARTY-NUMBER>> IE is included and set to the Caller ID number from the Caller ID request and the <<CALLING-PARTY-NAME>> IE is included and set to the Caller ID name from the Caller ID request.

Step 4:

Each PP replies with a CC-ALERTING message indicating that the PP is ringing.

Step 5:

The FP sends an IWU-INFO message to the PP with the <<TIME-DATE>> IE set according to the time field of the Caller ID request.

Step 6:

If necessary, the FP will send CC-INFO messages to each PP to turn ringing on and off in order to match the configured ring cadence for RS.

Step 7:

Once ringing is complete the FP will send a CC-RELEASE message to each PP to stop ringing. The call is released at this point since the Call Agent did not create a connection on the FP for the purpose of servicing an inbound call.

Step 8:

Each PP responds with a CC-RELEASE-COM message to the FP.

I.8 Call Waiting – Multiple Connections

#	DECT PP	DECT FP / E-MTA	Call Agent
1			<- RQNT(wt1,ci)
2			200 ->
3		<- CC-INFO(cid name & #)	
4		<- IWU-INFO(cid time)	
5	CC-INFO(keypad=15H)	->	
6		NTFY(hf)	->
7		<- 200	
8		<- RQNT(hf,hu)	
9		200 ->	
10		<- MDCX(A:inactive)	
11		200 ->	
12		<- CRCX(B:sdp-r2)	
13		200(sdp-12)	->
14		<- Change Codec	
15	Codec Changed	->	
16	CC-INFO(keypad=15H)	->	
17		NTFY(hf)	->
18		<- 200	
19		<- RQNT(hf,hu)	
20		200 ->	
21		<- MDCX(B:inactive)	
22		200 ->	
23		<- MDCX(A:sendrecv)	
24		200 ->	
25		<- Change Codec	
26	Codec Changed	->	

Assumptions / background information:

- An active call is in progress with a single NCS connection (A) using a compressed narrowband Codec (e.g., G.729) using full slot.
- The register recall button is used to accept the incoming call.

Step 1:

The call agent issues a request for notification to play the call waiting tone and present caller ID information.

```
RQNT 100 aaln/1@ep.sample.com MGCP 1.0 NCS 1.0
X: 50
S: wt1, ci(07/28/09/51, 8675309, Jenny)
R: hf, hu
```

Step 2:

The endpoint acknowledges the RQNT.

```
200 100 OK
```

Step 3:

The FP sends a CC-INFO message to the PP with a request to display caller ID. The <<CALLING-PARTY-NUMBER>> IE is included and set to the Caller ID number from the Caller ID request and the <<CALLING-PARTY-NAME>> IE is included and set to the Caller ID name from the Caller ID request.

The FP generates the requested call waiting tone. Note that the CC-INFO message is sent in parallel with the application of the call waiting tone. There is no need to wait until the first iteration of the call waiting tone is complete before sending the CC-INFO message.

Step 4:

The FP sends an IWU-INFO message to the PP with the <<TIME-DATE>> IE set according to the time field of the Caller ID request.

Step 5:

The user presses the flash (i.e., register recall) key. The PP sends a CC-INFO message containing the <<KEYPAD>> or <<MULTI-KEYPAD>> IE with the control code set to 15H.

Step 6:

The FP generates a flash hook event resulting in a notification to the Call Agent.

```
NTFY 200 aaln/1@ep.sample.com MGCP 1.0 NCS 1.0
X: 50
O: hf
```

Step 7:

The Call Agent acknowledges the NTFY.

```
200 200 OK
```

Step 8:

The Call Agent sends a new request for notification to notify the flash hook event.

```
RQNT 101 aaln/1@ep.sample.com MGCP 1.0 NCS 1.0
X: 51
R: hf, hu
```

Step 9:

The endpoint acknowledges the RQNT.

```
200 101 OK
```

Step 10:

The Call Agent modifies the existing connection to put it on hold.

```
MDCX 102 aaln/1@ep.sample.com MGCP 1.0 NCS 1.0
C: 51005E4E0003A9ED1700
I: 3
M: inactive
```

Step 11:

The endpoint acknowledges the MDCX.

```
200 102 OK
```

Step 12:

The Call Agent creates a new connection with SDP from the waiting remote endpoint.

```
CRCX 103 aaln/1@ep-o.sample.com MGCP 1.0 NCS 1.0
C: 51005E4E0003A9ED1700
M: inactive
L: mp:20;20, a:G722;PCMU
<sdp-r2 (G722,PCMU)>
```

Step 13:

The endpoint creates the connection and acknowledges the CRCX.

```
200 103 OK
I: 4
<sdp-o2 (G722,PCMU)>
```

Step 14:

The FP requests a Codec change since there now exists at least one connection over the network using a wideband Codec requiring long slot. The existing connection is using a compressed narrowband Codec (e.g., G.729) requiring only full slot.

Step 15:

The change Codec procedure is completed.

Step 16:

The user presses the flash (i.e., register recall) key. The PP sends a CC-INFO message containing the <<KEYPAD>> or <<MULTI-KEYPAD>> IE with the control code set to 15H.

Step 17:

The FP generates a flash hook event resulting in a notification to the Call Agent.

```
NTFY 201 aaln/1@ep.sample.com MGCP 1.0 NCS 1.0
X: 51
O: hf
```

Step 18:

The Call Agent acknowledges the NTFY.

```
200 201 OK
```

Step 19:

The Call Agent sends a new request for notification to notify the flash event.

```
RQNT 104 aaln/1@ep.sample.com MGCP 1.0 NCS 1.0
X: 52
R: hf, hu
```

Step 20:

The endpoint acknowledges the RQNT.

```
200 104 OK
```

Step 21:

The Call Agent modifies the 2nd connection to put it on hold.

```
MDCX 105 aaln/1@ep.sample.com MGCP 1.0 NCS 1.0
C: 51005E4E0003A9ED1700
I: 4
M: inactive
```

Step 22:

The endpoint acknowledges the MDCX.

```
200 105 OK
```

Step 23:

The Call Agent modifies the waiting connection to SENDRECV.

MDCX 106 aaln/1@ep.sample.com MGCP 1.0 NCS 1.0
C: 51005E4E0003A9ED1700
I: 3
M: sendrecv

Step 24:

The endpoint acknowledges the MDCX.

200 106 OK

Steps 25-26:

Note that the DECT air Codec does not change in this particular example for two reasons. First, there still exists network Codecs requiring the use of long slot (i.e., G.722 and PCMU) even though they are not currently active over the network. And second, once the DECT air slot type is modified to long slot after network Codec negotiation is complete (as in this case) then it should be maintained throughout the life of the call to avoid service interruption.

Appendix II Illustrative Implementation of the NBCS feature in NCS Environment

One of the optional requirements for the PacketCable HD Voice Clients is the ability to implement the NBCS feature. A complete description of the feature is specified in [HDV].

The implementation of the NBCS feature execution in HD Voice NCS E-MTA Clients requires several assumptions to be made on the way in which the CMS interacts with the NCS Clients and potentially may require the modifications of the NCS Protocol Specification. Such modifications are related to a need of the CMS to communicate the specific nature of the NBCS call, for the E-MTA to take the corresponding actions on activation of the speakers on the NCS Client, and on the DECT PPs. Given the limitations, the HD Voice E-MTA Clients are not required to be able to implement the NBCS feature.

However, to provide a smooth NBCS co-existence of the E-MTA Clients (HD Voice capable or otherwise) and HD Voice E-DVA Devices in the customers' premises, it is still desirable if the E-MTA Clients are able to answer the NBCS call when such call is targeting the terminating HD Voice E-DVA Device.

Under this scenario, the following assumptions are made:

- There is at least one HD Voice E-DVA Device configured with the NBCS feature and installed in the customer's (subscriber's) premises.
- There is at least one E-MTA Device (HD Voice capable or otherwise) installed in the customer's premises,
- An indication of the NBCS call can be observed by the customer when the call is made and NBCS feature is in progress on one of the HD Voice E-DVA Devices. The particular type of an indication used to alert the customer on the NBCS call being in progress is not defined and can be different. As an example, it can be assumed that the voice mail message and caller's voice played by the HD Voice E-DVA Device can be heard by the customer and can serve as an indicator of the NBCS call in progress.
- The customer should be able to answer the NBCS call by picking up the handset of the E-MTA Device configured for such purposes on the network side.

The implementation of the described NBCS behavior requires the interaction between the NBCS Application Server (AS) and the CMS. During such interaction the CMS should be informed on the NBCS call being in progress for the particular subscriber and on the E-MTAs (either HD Voice capable or not) which may potentially answer the NBCS call. The particular means of communication between the AS and corresponding CMS are outside of the scope of this specification.

The following paragraphs provide a general description of one potential illustrative implementation approach for the NBCS feature in NCS environment given the assumptions above.

Upon the initiation of the NBCS feature on one of the customer's terminating HD Voice E-DVA Client configured with NBCS feature, the AS provides to the corresponding CMS the information on the customer's E-MTAs, which are configured to be able to potentially answer the NBCS call.

As an alternative approach, the NBCS AS may always notify the CMS corresponding to the terminating E-DVA on every NBCS call being initiated. Upon receipt of such notification, the CMS can determine if there are, in fact, E-MTAs corresponding to the terminating E-DVA and configured to potentially answer the NBCS call.

Upon determination that such terminating E-MTA(s) exists, a CMS uses the NCS signaling to prevent the E-MTA from generating the dial tone when the handset (either POTS or DECT) is picked up. When the handset on the answering E-MTA is picked up, the CMS instructs the E-MTA to not collect the digits. After that, the CMS issues to E-MTA the NCS command to create the connection. The answering E-MTA acknowledges this command by sending its SDP to the CMS.

Upon receipt of the E-MTA's SDP, the CMS communicates this SDP to the NBCS AS, which, in turn, proceeds with the following flows:

- issue the SIP commands to communicate to the calling E-DVA the SDP of the answering E-MTA;

- issue the necessary SIP commands to the Voice Mail Server and to the terminating E-DVA to delete the voice path between them;
- issue the necessary SIP commands to the terminating E-DVA and to the calling E-DVA to delete the voice path between them;
- issue the necessary SIP commands to communicate to the CMS the SDP of the calling E-DVA.

These flows result in the termination of the NCS feature execution on both sides - calling and terminating E-DVAs. Upon the receipt of the SDP of the calling E-DVA, the CMS issues to the answering E-MTA the NCS command to modify the existing connection created previously. Once successfully executed by the answering E-MTA, this command results in the establishment of the voice path between the calling E-DVA and answering E-MTA.

The usual two-party call between the two networks can be used beyond this point for further call modification and termination.

Appendix III Acknowledgements

The PacketCable team wishes to recognize the following individuals for their significant involvement and contributions to this specification (ordered alphabetically by company name and individual's first names in each company).

Billy Hare, Arris (Lead Author)

Gordon Li, Broadcom

Eugene Nechamkin, Broadcom

Effi Shiri, DSP Group

Dave Ellis, Motorola

Jerry Mahle, Motorola

Mark Trayer, Samsung

Oliver Maiwald, SiTel

The following CableLabs staff is thanked for their contributions to this specification: David Hancock, Jean-Francois Mule, Kevin Johns, Eduardo Cardona, Stuart Hoggan, Sandeep Sharma, and Bernie McKibben.

Joey Padden, CableLabs

Appendix IV Revision History

The following Engineering Change Notice was incorporated into PKT-SP-DECT-NCS-I02-090917.

ECN	Date Accepted	Summary
DECT-NCS-N-09.0580-1	6/22/09	NBCS Feature Execution in NCS Environment

The following Engineering Change Notice was incorporated into PKT-SP-DECT-NCS-I03-120412.

ECN	Date Accepted	Summary
DECT-NCS-N-12.0670-2	2/27/12	G.722 Codec Literal Name Corrections

The following Engineering Change Notices were incorporated into PKT-SP-HDV-NCS-I04-120823.

ECN	Date Accepted	Summary
DECT-NCS-N-12.0677-2	4/30/2012	Clarify codec requirements during 3WC (NCS)
DECT-NCS-N-12.0683-1	7/9/2012	Adding analog interface to DECT-NCS specs
HDV-NCS-N-12.0690-1	8/23/2012	G.722 Codec SDP Formatting for NCS