

# **DOCSIS® Provisioning of EPON Specifications**

## **DPoEv2.0**

### **DPoE IP Network Element Requirements**

#### **DPoE-SP-IPNEv2.0-I05-150611**

**ISSUED**

#### **Notice**

This DPoE™ specification is the result of a cooperative effort undertaken at the direction of Cable Television Laboratories, Inc. for the benefit of the cable industry and its customers. You may download, copy, distribute, and reference the documents herein only for the purpose of developing products or services in accordance with such documents, and educational use. Except as granted by CableLabs® in a separate written license agreement, no license is granted to modify the documents herein (except via the Engineering Change process), or to use, copy, modify or distribute the documents for any other purpose.

This document may contain references to other documents not owned or controlled by CableLabs. Use and understanding of this document may require access to such other documents. Designing, manufacturing, distributing, using, selling, or servicing products, or providing services, based on this document may require intellectual property licenses from third parties for technology referenced in this document. To the extent this document contains or refers to documents of third parties, you agree to abide by the terms of any licenses associated with such third party documents, including open source licenses, if any.

© Cable Television Laboratories, Inc., 2012-2015

## DISCLAIMER

This document is furnished on an "AS IS" basis and neither CableLabs nor its members provides any representation or warranty, express or implied, regarding the accuracy, completeness, noninfringement, or fitness for a particular purpose of this document, or any document referenced herein. Any use or reliance on the information or opinion in this document is at the risk of the user, and CableLabs and its members shall not be liable for any damage or injury incurred by any person arising out of the completeness, accuracy, or utility of any information or opinion contained in the document.

CableLabs reserves the right to revise this document for any reason including, but not limited to, changes in laws, regulations, or standards promulgated by various entities, technology advances, or changes in equipment design, manufacturing techniques, or operating procedures described, or referred to, herein.

This document is not to be construed to suggest that any company modify or change any of its products or procedures, nor does this document represent a commitment by CableLabs or any of its members to purchase any product whether or not it meets the characteristics described in the document. Unless granted in a separate written agreement from CableLabs, nothing contained herein shall be construed to confer any license or right to any intellectual property. This document is not to be construed as an endorsement of any product or company or as the adoption or promulgation of any guidelines, standards, or recommendations.

## Document Status Sheet

<b>Document Control Number:</b>	DPoE-SP-IPNEv2.0-I05-150611			
<b>Document Title:</b>	DPoE IP Network Element Requirements			
<b>Revision History:</b>	I01 – Released 12/13/2012 I02 – Released 11/14/2013 I03 – Released 08/07/2014 I04 – Released 03/19/2015 I05 – Released 06/11/2015			
<b>Date:</b>	June 11, 2015			
<b>Status:</b>	<del>Work in Progress</del>	<del>Draft</del>	<del>Issued</del>	<del>Closed</del>
<b>Distribution Restrictions:</b>	<del>Author Only</del>	<del>CL/Member</del>	<del>CL/Member/Vendor</del>	<del>Public</del>

### Key to Document Status Codes

- Work in Progress** An incomplete document, designed to guide discussion and generate feedback that may include several alternative requirements for consideration.
- Draft** A document in specification format considered largely complete, but lacking review by Members and vendors. Drafts are susceptible to substantial change during the review process.
- Issued** A generally public document that has undergone Member and Technology Supplier review, cross-vendor interoperability, and is for Certification testing if applicable. Issued Specifications are subject to the Engineering Change Process.
- Closed** A static document, reviewed, tested, validated, and closed to further engineering change requests to the specification through CableLabs.

### Trademarks

CableLabs® is a registered trademark of Cable Television Laboratories, Inc. Other CableLabs marks are listed at <http://www.cablelabs.com/certqual/trademarks>. All other marks are the property of their respective owners.

## Table of Contents

<b>1</b>	<b>INTRODUCTION .....</b>	<b>7</b>
1.1	DPoE Technology Introduction .....	7
1.2	Scope .....	7
1.3	Goals .....	8
1.4	Requirements .....	8
1.5	DPoE Version 2.0 Specifications.....	8
1.6	Reference Architecture .....	9
1.7	DPoE Interfaces and Reference Points .....	9
<b>2</b>	<b>REFERENCES .....</b>	<b>13</b>
2.1	Normative References.....	13
2.2	Informative References.....	17
2.3	Reference Acquisition.....	18
<b>3</b>	<b>TERMS AND DEFINITIONS .....</b>	<b>19</b>
3.1	DPoE Network Elements .....	19
3.2	Other Terms and Definitions .....	21
<b>4</b>	<b>ABBREVIATIONS AND ACRONYMS .....</b>	<b>22</b>
<b>5</b>	<b>IPNE FUNCTIONS (INFORMATIVE) .....</b>	<b>26</b>
<b>6</b>	<b>DPOE SYSTEM IPNE REQUIREMENTS.....</b>	<b>27</b>
6.1	Network Element Access Methods and Operations.....	27
6.1.1	<i>Command Line Interface</i> .....	27
6.1.2	<i>Terminal Access</i> .....	27
6.1.3	<i>Lights Out Management</i> .....	27
6.1.4	<i>Secure Login</i> .....	28
6.1.5	<i>Client Applications</i> .....	28
6.1.6	<i>Command Logging</i> .....	28
6.1.7	<i>XML Management</i> .....	29
6.1.8	<i>Power Saving</i> .....	29
6.1.9	<i>SNMP</i> .....	29
6.2	Messages.....	30
6.3	System Configuration File .....	30
6.4	DPoE System Executable Software (Images).....	31
6.4.1	<i>System Image Storage and Control</i> .....	31
6.5	File Transfer .....	31
6.6	File Storage and Control .....	31
6.6.1	<i>Integrated</i> .....	31
6.6.2	<i>Pluggable Storage</i> .....	32
6.6.3	<i>Local Log</i> .....	32
6.7	Logs .....	32
6.8	Syslog Configuration .....	32
6.9	Network Element Addressing.....	32
6.9.1	<i>Loopback IP Address</i> .....	32
6.9.2	<i>I-BEB</i> .....	33
6.9.3	<i>IPv4 Addressing</i> .....	33
6.9.4	<i>IPv6 Addressing</i> .....	33
6.10	Management Addresses .....	34
6.11	Documentation Requirements.....	35
6.12	IP Services .....	37

6.12.1	<i>Other Daemons</i> .....	37
6.12.2	<i>DHCP Relay Configuration</i> .....	37
6.13	Physical Product Requirements .....	38
6.13.1	<i>General Requirements</i> .....	38
6.13.2	<i>Power Requirements</i> .....	38
6.13.3	<i>Rack Mount Requirements</i> .....	38
6.13.4	<i>Cabling</i> .....	39
6.13.5	<i>Grounding</i> .....	39
6.13.6	<i>Environmental Requirements</i> .....	39
6.14	Message of the Day .....	39
6.15	Broadband Intercept.....	39
6.16	Diagnostics .....	39
6.16.1	<i>System Diagnostics</i> .....	39
6.16.2	<i>IP Statistics</i> .....	39
6.16.3	<i>Ethernet Diagnostics</i> .....	40
6.17	Certificate Entry.....	40
6.18	Power Saving.....	40
<b>7</b>	<b>EPON-SPECIFIC IPNE REQUIREMENTS .....</b>	<b>41</b>
7.1	EPON Performance .....	41
7.2	EPON Configuration .....	41
7.2.1	<i>10G-EPON and 1G-EPON Compatibility Settings</i> .....	41
7.2.2	<i>ONU Rate Mode Capability</i> .....	41
7.2.3	<i>2G-EPON Compatibility Requirements</i> .....	41
7.2.4	<i>EPON OAM Configuration</i> .....	42
7.2.5	<i>EPON (TU) Interface Objects</i> .....	43
7.2.6	<i>EPON TUL Interface Objects</i> .....	44
7.2.7	<i>Fault Management</i> .....	44
7.2.8	<i>LLDP Configuration</i> .....	44
7.3	Virtual Cable Modem Display and Configuration .....	45
7.4	EPON Diagnostics .....	46
7.5	Multi-Source Agreement Transceivers .....	46
7.6	VCM Logging.....	46
<b>8</b>	<b>DPOE PROTOCOL SPECIFIC SUPPORT .....</b>	<b>47</b>
8.1	MULPI Parameters .....	47
8.1.1	<i>Bundling</i> .....	47
8.1.2	<i>IP Serving Groups</i> .....	47
8.1.3	<i>IP(HSD) and L2HSD Services</i> .....	48
8.1.4	<i>VPN S-VID Allocation</i> .....	49
8.2	MEF Parameters .....	49
8.2.1	<i>Encapsulation and Tagging</i> .....	49
8.2.2	<i>TPID Translation</i> .....	49
8.2.3	<i>I-BEB</i> .....	50
<b>9</b>	<b>COMBINED IP(HSD) AND MEF NNI FORWARDING REQUIREMENTS .....</b>	<b>51</b>
9.1	Ethernet Interface Requirements.....	51
9.1.1	<i>Link Aggregation (LAG)</i> .....	51
9.1.2	<i>D and MN Interface Data Rates</i> .....	51
9.1.3	<i>NNI Link Aggregation</i> .....	51
9.2	IP Forwarding Requirements .....	52
9.2.1	<i>IP Interfaces</i> .....	52
9.2.2	<i>IP(HSD) Multicast</i> .....	53
9.2.3	<i>SF and MESP QoS Assignment</i> .....	54
9.3	Routing and Forwarding .....	54
9.3.1	<i>Route Distribution</i> .....	54

9.3.2	<i>Bi-Directional Forwarding Detection</i> .....	54
9.3.3	<i>Equal Cost Multi-Path</i> .....	55
9.3.4	<i>Policy Based Routing</i> .....	55
9.3.5	<i>Static Routes</i> .....	55
9.3.6	<i>Default Route</i> .....	55
9.3.7	<i>Interior Gateway Protocols (IGPs)</i> .....	56
9.3.8	<i>BGP</i> .....	57
9.3.9	<i>Multicast</i> .....	59
9.3.10	<i>Multi-Protocol Label Switching (MPLS)</i> .....	60
9.4	<i>Host Routing</i> .....	63
9.4.1	<i>IPv4 Host Routing</i> .....	63
9.4.2	<i>IPv6 Host Routing</i> .....	63
9.5	<i>CMCI Routing</i> .....	64
9.6	<i>VCM Host Provisioning</i> .....	64
9.7	<i>Network Timing Support</i> .....	64
9.7.1	<i>Network Timing Profile</i> .....	65
9.7.2	<i>Global Timing Configuration</i> .....	65
<b>APPENDIX I CMTS EXAMPLE CONFIGURATION FILE A (INFORMATIVE)</b> .....		<b>66</b>
<b>APPENDIX II CMTS EXAMPLE CONFIGURATION B (INFORMATIVE)</b> .....		<b>74</b>
II.1	<i>CMTS Example Configuration B File with Explanations</i> .....	74
II.2	<i>CMTS Example Configuration File B</i> .....	83
<b>APPENDIX III EXAMPLE OF IS-IS CONFIGURATION (INFORMATIVE)</b> .....		<b>99</b>
<b>APPENDIX IV DPOE EXAMPLE CONFIGURATION FILE (INFORMATIVE)</b> .....		<b>100</b>
<b>APPENDIX V ACKNOWLEDGEMENTS (INFORMATIVE)</b> .....		<b>110</b>
<b>APPENDIX VI REVISION HISTORY</b> .....		<b>111</b>
VI.1	<i>Engineering Change for DPoE-SP-IPNEv2.0-I02-131114</i> .....	111
VI.2	<i>Engineering Changes for DPoE-SP-IPNEv2.0-I03-140807</i> .....	111
VI.3	<i>Engineering Change for DPoE-SP-IPNEv2.0-I04-150319</i> .....	111
VI.4	<i>Engineering Change for DPoE-SP-IPNEv2.0-I05-150611</i> .....	111

## Figures

Figure 1 - DPoEv2.0 Reference Architecture .....	9
Figure 2 - DPoEv2.0 Interfaces and Reference Points .....	10
Figure 3 - D-ONU Types .....	20
Figure 4 - DPoE Network Elements .....	20
Figure 5 - 2G-EPON System Backward Compatibility with 1G-EPON System .....	42

## Tables

Table 1 - DPoEv2.0 Series of Specifications .....	8
Table 2 - DPoEv2.0 Interface and Reference Point Descriptions .....	11
Table 3 - Index of Refraction for Common EPON Fiber Optic Media .....	65

# 1 INTRODUCTION

DOCSIS Provisioning of EPON (DPoE) Version 2.0 specifications are a joint effort of Cable Television Laboratories (CableLabs), cable operators, vendors, and suppliers to support EPON technology using existing DOCSIS-based back office systems and processes. DPoE v2.0 specifications augment the DPoE v1.0 specifications to provide requirements for additional service capabilities and corresponding provisioning and network management capabilities.

Ethernet PON (EPON) is an [802.3] standard for a passive optical network (PON). A PON is a specific type of multi-access optical network. A multi-access optical network is an optical fiber based network technology that permits more than two network elements to transmit and receive on the same fiber.

DPoE specifications are focused on DOCSIS-based provisioning and operations of Internet Protocol (IP) using DOCSIS Internet service (which is typically referred to as High Speed Data (HSD)), or IP(HSD) for short, and Metro Ethernet services as described by Metro Ethernet Forum (MEF) standards. DPoE Networks offer IP(HSD) services, functionally equivalent to DOCSIS networks, where the DPoE System acts like a DOCSIS CMTS and the DPoE System and DPoE Optical Network Unit (ONU) together act like a DOCSIS CM.

## 1.1 DPoE Technology Introduction<sup>1</sup>

DPoE technology was established with the following common requirements already developed by operators. Each of the participant operators had previously selected 1G-EPON and 10G-EPON as the appropriate technology for one or more applications. EPON is a widely deployed technology with a sufficient and large supply of vendors offering a variety of products for each component of the access network. 2G-EPON, as described Annex A of [DPoE-PHYv2.0], uses the same 1G upstream as 1G-EPON (operates at the effective rate of 1 Gbps), but provides a 2G downstream (operates at the effective rate of 2 Gbps). With the exception of requirements specified in Annex A of [DPoE-PHYv2.0], 2G-EPON is expected to meet all of the requirements specified for 1G-EPON. 10G-EPON technology is available and is backwards compatible with 1G-EPON. A 1G-EPON network can be incrementally upgraded to 10G-EPON, adding or replacing ONUs as business needs require. 1G-EPON, 2G-EPON, and 10G-EPON are compatible with [SCTE 174].

1G-EPON and 10G-EPON, originally defined in [802.3ah] and [802.3av] respectively, support a point-to-multipoint architecture with a centralized controller called an Optical Line Terminal (OLT) and distributed low cost Layer 2 ONUs. The basic service mapping architecture in EPON is to map Ethernet (or IP) frame header information (e.g., addresses, IP Differentiated Service Code Points, Ethernet Q tag, S-VLAN/C-VLAN ID, ISID, bridge address, etc.) to a logical circuit called a Logical Link Identifier (LLID) in [802.3]. The service mapping function in DPoE specifications is similar to that used in DOCSIS specifications. Both DOCSIS and DPoE networks rely on a centralized scheduler though EPON utilizes an LLID which functions like a SID in DOCSIS to support unicast, broadcast, and multicast.

At the time when development efforts around the DPoE specifications started, there were no standard management interfaces for the ongoing operations and maintenance of the network, including fault management, performance management, security, etc. Operators already had fully working and scaled-out systems that solve these challenges for DOCSIS networks. One of the primary goals for DPoE specifications was therefore to use the existing DOCSIS back office infrastructure to scale up EPON-based business services.

## 1.2 Scope<sup>2</sup>

As the name suggests, the scope for this document is the MAC and upper layer protocols for DPoE Networks. The MAC in DPoE Networks is EPON. This specification does not place any additional requirements on the EPON MAC beyond the [802.3] specifications for EPON. The first set of requirements is for the support of DOCSIS-based Operations Administration Maintenance and Provisioning (OAMP) for the MAC and upper layer protocols as specified in [MULPIv3.0]. The second set of requirements is in addition to the above functionality traffic

<sup>1</sup> Revised per IPNEv2.0-N-14.0170-1 and IPNEv2.0-N-14.0186-1 on 7/11/14 by JB.

<sup>2</sup> Revised per IPNEv2.0-N-14.0170-1 on 7/11/14 by JB.

classification (as provisioned) and traffic forwarding (as both provisioned and according to the requirements set forth in this specification).

The primary additions to the DOCSIS specifications are the requirements and accompanying specifications for Metro Ethernet services as described in [DPoE-MEFv2.0].

### 1.3 Goals

The objective of this specification is to document the requirements to support the automated provisioning of IP High Speed Data Services and Metro Ethernet services over EPON network using DOCSIS provisioning methods and backend servers. The intention of this document is to specify requirements and guidelines to assure interoperability between DPoE products. The idea is to establish requirements that are in addition and in some cases in replacement of requirements in DOCSIS 3.0.

### 1.4 Requirements

Throughout this document, the words that are used to define the significance of particular requirements are capitalized. These words are:

"MUST"	This word means that the item is an absolute requirement of this specification.
"MUST NOT"	This phrase means that the item is an absolute prohibition of this specification.
"SHOULD"	This word means that there may exist valid reasons in particular circumstances to ignore this item, but the full implications should be understood and the case carefully weighed before choosing a different course.
"SHOULD NOT"	This phrase means that there may exist valid reasons in particular circumstances when the listed behavior is acceptable or even useful, but the full implications should be understood and the case carefully weighed before implementing any behavior described with this label.
"MAY"	This word means that this item is truly optional. One vendor may choose to include the item because a particular marketplace requires it or because it enhances the product, for example; another vendor may omit the same item.

### 1.5 DPoE Version 2.0 Specifications

A list of the specifications included in the DPoE 2.0 series is provided in Table 1. For further information please refer to <http://www.cablelabs.com/specs/specification-search/?cat=dpoee&scat=dpoee-2-0>.

**Table 1 - DPoEv2.0 Series of Specifications**

Designation	Title
DPoE-SP-ARCHv2.0	DPoE Architecture Specification
DPoE-SP-DEMARCv2.0	DPoE Demarcation Device Specification
DPoE-SP-OAMv2.0	DPoE OAM Extensions Specification
DPoE-SP-PHYv2.0	DPoE Physical Layer Specification
DPoE-SP-SECv2.0	DPoE Security and Certificate Specification
DPoE-SP-IPNEv2.0	DPoE IP Network Element Requirements
DPoE-SP-MULPIv2.0	DPoE MAC and Upper Layer Protocols Interface Specification
DPoE-SP-MEFv2.0	DPoE Metro Ethernet Forum Specification
DPoE-SP-OSSIV2.0	DPoE Operations and Support System Interface Specification
DPoE-SP-SOAMv2.0	DPoE Service-OAM Specification



### 1.6 Reference Architecture

The DPoE reference architecture shown in Figure 1 identifies the elements that a DPoE Network minimally requires to illustrate and communicate the physical hardware and logical software interfaces between the functional subsystems of the DPoE architecture. The principal elements in the architecture are the DPoE System that resides in the headend or hub site, and the D-ONU (D-ONU) which may be an off-the-shelf EPON ONU, EPON SFP-ONU, or an EPON ONU with additional subsystems. The remaining elements in the architecture are existing servers and systems in the operator's network. All the server elements have connectivity through an IP (TCP/IP) network. Transport of bearer traffic, and (in some cases) Layer 2 OAM Protocol Data Units (PDUs) are available through either IP or Layer 2 Ethernet-based Network Interfaces.

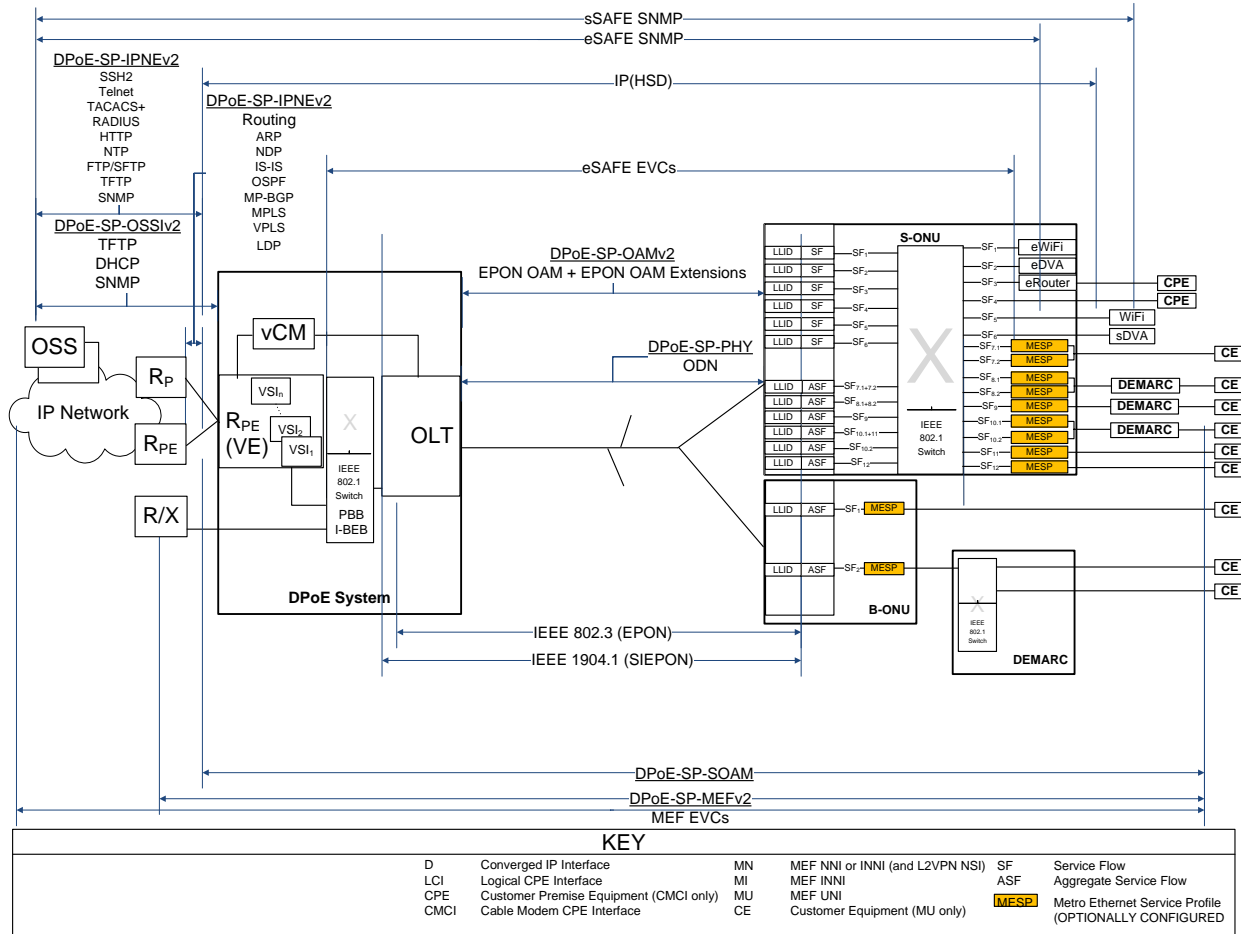

Figure 1 - DPoEv2.0 Reference Architecture

### 1.7 DPoE Interfaces and Reference Points

The DPoE interfaces and reference points shown in Figure 2 provide a basis for the description and enumeration of DPoE specifications for the DPoE architecture. Each interface or reference point indicates a point between separate subsystems. The reference points have protocols that run across them, or have a common format of bearer traffic (with no signaling protocol). All the interfaces are bi-directional interfaces that support two-way communications. The protocols in DPoE specifications operate within different layers based on the [802.3], [802.1], IETF, MEF, and CableLabs specifications. The C reference points are uni-directional for upstream (C<sub>0</sub>) or downstream (C<sub>S</sub>) classification, respectively.

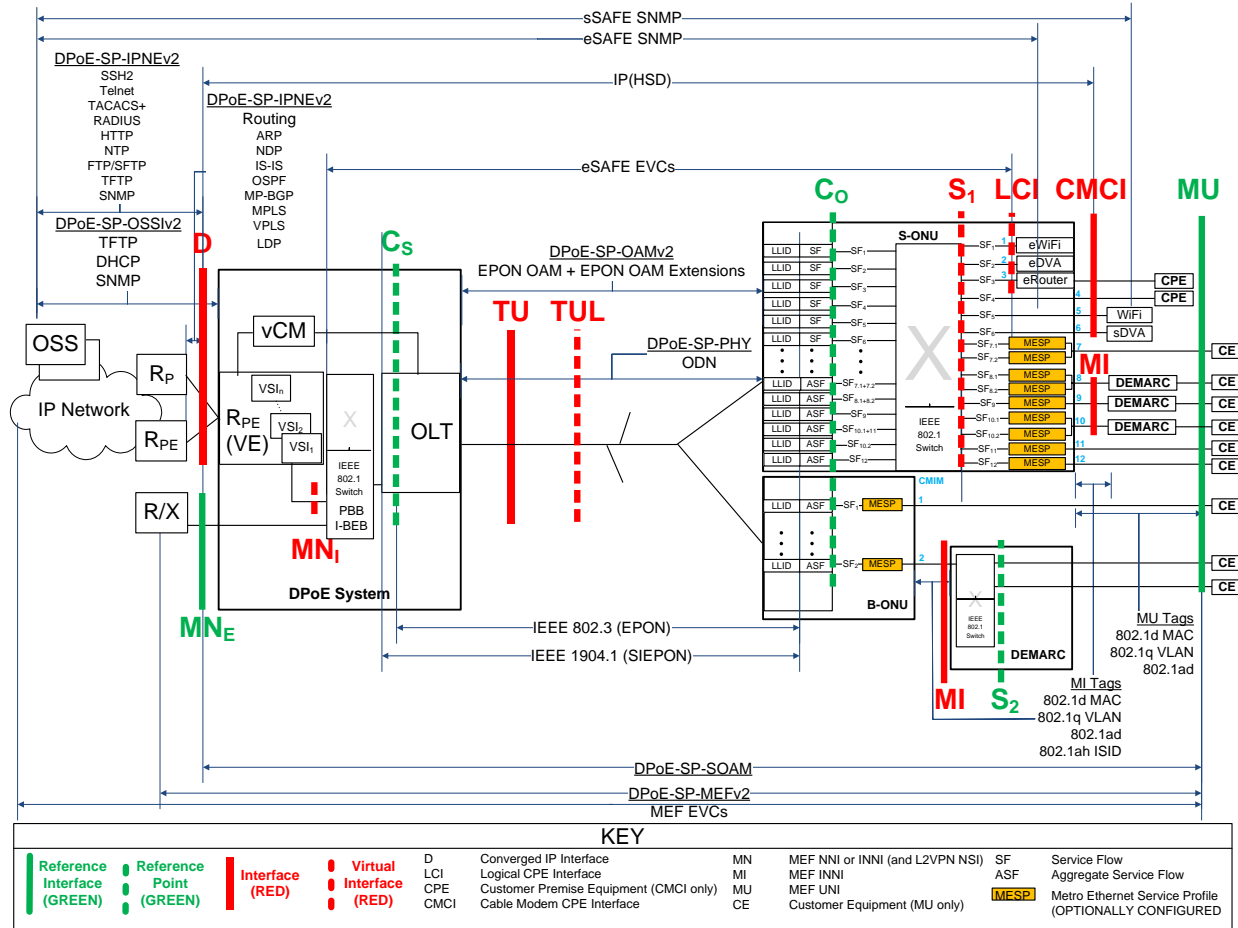

Figure 2 - DPoEv2.0 Interfaces and Reference Points

**Table 2 - DPoEv2.0 Interface and Reference Point Descriptions**

Interface or Reference Point		Interface or Reference Point Description
MN		MN is a logical concept used for the specification of requirements for MEF INNI that apply to both MN <sub>E</sub> and MN <sub>I</sub> . MN logically provides the equivalent function of a MEF INNI or L2VPN NSI. It is an NNI for Metro Ethernet services only.
	MN <sub>E</sub>	The MN <sub>E</sub> (MEF INNI External) interface is a substitute for the MN reference interface from DPoE version 1.0 specifications. The MN interface is an [802.3] interface for Ethernet (or MEF or L2VPN emulated) services only. It serves the role of a MEF INNI or L2VPN NSI. It is an NNI for Metro Ethernet services only.
	MN <sub>I</sub>	The MN <sub>I</sub> reference interface is used to describe the virtual interface between an OLT and a VPLS Virtual Switch Instance (VSI). In particular, it is used to describe the requirements for stitching VSIs to DPoE System and OLT [802.1] components such as [802.1D] bridge groups, [802.1ad] S-VLAN or C-VLAN (S-component or C-component), or [802.1ad] I-BEB (I-component) or B-BEB (B-component) backbone edge bridges. The DPoE System stitches VPLS and VPWS transport and forwarding for Metro Ethernet Services between the D interface and the MN <sub>I</sub> reference interface <sup>3</sup> .
D		The D interface is the DOCSIS IP NNI interface. It is an operator network facing interface, sometimes called a Network Systems Interface (NSI) in DOCSIS specifications. The D interface allows a DPoE System to communicate with an IP network. The D interface carries all IP management traffic including OSSI and IP NE traffic. The D interface carries all DOCSIS IP service traffic, IP/MPLS/VPLS traffic, and IP/MPLS/VPWS traffic.
TU		The TU interface is a short form of expressing the interface between the DPoE System and the D-ONU.
TUL		The TUL interface is a virtual interface representing a logical EPON on an ODN. Each ODN has at least one TUL, and each TUL represents a MAC domain.
C		The C reference point is used for explanation of traffic ingress to a DPoE classifier.
	C <sub>O</sub>	The C <sub>O</sub> reference point is used for explanation of traffic ingress to a D-ONU upstream classifier.
	C <sub>S</sub>	The C <sub>S</sub> reference point is used for explanation of traffic ingress to a DPoE System downstream classifier.
S		The S interface is an IEEE 802 interface. The S interface may be an internal interface, such as [802.3] across a SERDES (GMII or XGMII) interface in a BP-ONU (such as a SFP-ONU, SFP+ONU or XFP-ONU), or it may be an external Ethernet interface in a BB-ONU or S-ONU. S <sub>1</sub> is an interface for an S-ONU. S <sub>2</sub> is a reference point used for explanation of services with the B-ONU.
	S <sub>1</sub>	The S <sub>1</sub> interfaces are the general case of all interfaces on an S-ONU. S <sub>1</sub> interfaces may be CMCI, LCI, MI, or MU interfaces.
	S <sub>2</sub>	The S <sub>2</sub> reference point is used for explanation of traffic ingress to and egress from interfaces on a DEMARC device in a DPoE System. Although there are no specifications or requirements for the S <sub>2</sub> reference point, informative text refers to the S <sub>2</sub> reference point to provide the full context for the use of a B-ONU with a DEMARC device providing Metro Ethernet services.
LCI		The Logical CPE Interface (LCI) interface is an eDOCSIS interface as defined in [eDOCSIS]. eSAFEs are connected to LCI interfaces.
CMCI		CMCI is the DPoE interface equivalent of the DOCSIS Cable Modem CPE Interface as defined in [CMCIv3.0]. This is the service interface for DOCSIS-based IP services. Customer Premise Equipment (CPE) is connected to CMCI interfaces.

<sup>3</sup> MN<sub>I</sub> is required for IP-based forwarding and transport of Metro Ethernet services with DPoE in order to provide MEF E-LAN and E-Tree services described in DPoE version 2.0. While these services can be constructed with MN<sub>E</sub>, these specifications do not describe the process to do so.

<b>Interface or Reference Point</b>	<b>Interface or Reference Point Description</b>
MI	<p>MI is an S interface that operates as a MEF INNI with additional requirements as specified in [DPoE-MEFv2.0]. The MI interface is an [802.3] interface (or reference point) between a D-ONU and a DEMARC device.</p> <ul style="list-style-type: none"> <li>• A D-ONU that provides a MEF INNI has an MI interface.</li> <li>• A D-ONU can have MU as an interface and an MI reference point on different S interfaces in a single D-ONU.</li> </ul> <p>DEMARC devices are connected to MI interfaces.</p>
MU	<p>MU is an S interface (or S reference interface) that operates as a MEF UNI. The MU reference interface is an [802.3] interface (or reference point) between a D-ONU or a DEMARC device and a customer's equipment.</p> <ul style="list-style-type: none"> <li>• A D-ONU that directly provides a MEF UNI (MU) interface has MU as an interface.</li> <li>• A D-ONU can have MU as an interface and an MI reference point on different S interfaces in a single D-ONU.</li> </ul> <p>Customer Edge (CE) devices are connected to MU interfaces.</p>

## 2 REFERENCES<sup>4</sup>

### 2.1 Normative References

In order to claim compliance with this specification, it is necessary to conform to the following standards and other works as indicated, in addition to the other requirements of this specification. Notwithstanding, intellectual property rights may be required to use or implement such normative references. At the time of publication, the editions indicated were valid. All references are subject to revision, and users of this document are encouraged to investigate the possibility of applying the most recent editions of the documents listed below. References are either specific (identified by date of publication, edition number, version number, etc.) or non-specific. For a non-specific reference, the latest version applies.

In this specification, terms "802.1ad" and "802.1ah" are used to indicate compliance with the [802.1ad] and [802.1ah] standards, respectively, now incorporated as part of [802.1Q]. For all intents and purposes, claiming compliance to [802.1Q], [802.1ad] or [802.1ah] in the scope of this specification will be treated as claiming compliance to IEEE Std 802.1Q-2011. Unless otherwise stated, claiming compliance to 802.1q-2005 requires a specific date reference.

[802.1]	Refers to entire suite of IEEE 802.1 standards unless otherwise specified.
[802.1ad]	IEEE Std 802.1ad-2005 <sup>TM</sup> , IEEE Standard for Local and Metropolitan Area Networks – Virtual Bridged Local Area Networks Amendment 4: Provider Bridges, May 2006. Former amendment to 802.1Q, now part of 802.1Q-2011.
[802.1ah]	IEEE Std 802.1ah-2008, IEEE Standard for Local and Metropolitan Area Networks – Virtual Bridged Local Area Networks – Amendment 6: Provider Backbone Bridges, January 2008. Former amendment to 802.1Q, now part of 802.1Q-2011.
[802.1D]	IEEE Std 802.1d <sup>TM</sup> -2004, IEEE Standard for Local and Metropolitan Area Networks: Media Access Control (MAC) Bridges.
[802.1Q]	IEEE Std 802.1Q-2011, IEEE Standard for Local and Metropolitan Area Networks - Media Access Control (MAC) Bridges and Virtual Bridge Local Area Networks, August 2011.
[802.3]	IEEE Std 802.3-2012, IEEE Standard for Ethernet, December 2012.
[802.3ah]	IEEE Std 802.3ah <sup>TM</sup> -2004, IEEE Standard for Information technology-Telecommunications and information systems-Local and metropolitan area networks-Specific requirements, Part 3: Carrier Sense Multiple Access with Collision Detection (CSMA/CD) Access Method and Physical Layer Specifications, Amendment: Media Access Control Parameters, Physical Layers, and Management Parameters for Subscriber Access Networks, now part of [802.3].
[802.3av]	IEEE Std 802.3av <sup>TM</sup> -2009, IEEE Standard for Information technology-Telecommunications and information systems-Local and metropolitan area networks-Specific requirements, Part 3: Carrier Sense Multiple Access with Collision Detection (CSMA/CD) Access Method and Physical Layer Specifications Amendment 1: Physical Layer Specifications and Management Parameters for 10Gb/s Passive Optical Networks, now part of [802.3].
[1588v2]	IEEE Std 1588-2008, IEEE Standard for a Precision Clock Synchronization Protocol for Networked Measurement and Control Systems.
[1904.1A]	IEEE Std 1904.1 <sup>TM</sup> -2013, IEEE Standard for Service Interoperability in Ethernet Passive Optical Networks (SIEPON), Package A.
[CANN DHCP-Reg]	CableLabs' DHCP Options Registry Specification, CL-SP-CANN-DHCP-Reg, <a href="http://www.cablelabs.com/specification/cablelabs-dhcp-options-registry-2/">http://www.cablelabs.com/specification/cablelabs-dhcp-options-registry-2/</a> , Cable Television Laboratories, Inc.

<sup>4</sup> Revised per IPNEv2.0-N-14.0170-1 on 7/11/14 by JB. Revised per IPNEv2.0-N-14.0197-1 on 11/18/14 by JB.

- [CBI2.0] Data-Over-Cable Service Interface Specifications, Cable Broadband Intercept Specification, CM-SP-CBI2.0, <http://www.cablelabs.com/specification/cable-broadband-intercept-2-0-specification/>, Cable Television Laboratories, Inc.
- [CMCIv3.0] Data-Over-Cable Service Interface Specifications, Cable Modem to Customer Premise Equipment Interface Specification, CM-SP-CMCIv3.0, <http://www.cablelabs.com/specification/docsis-cable-modem-to-cpe-interface-specification/>, Cable Television Laboratories, Inc.
- [DPoE-ARCHv2.0] DOCSIS Provisioning of EPON, DPoE Architecture Specification, DPoE-SP-ARCHv2.0, <http://www.cablelabs.com/specification/dpoe-architecture-specification-2/>, Cable Television Laboratories, Inc.
- [DPoE-DEMARCV2.0] DOCSIS Provisioning of EPON, DPoE Demarcation Device Specification, DPoE-SP-DEMARCV2.0, Cable Television Laboratories, Inc.
- [DPoE-MEFv2.0] DOCSIS Provisioning of EPON, Metro Ethernet Forum Specification, DPoE-SP-MEFv2.0, <http://www.cablelabs.com/specification/dpoe-metro-ethernet-forum-specification-2/>, Cable Television Laboratories, Inc.
- [DPoE-MULPIv2.0] DOCSIS Provisioning of EPON, MAC and Upper Layer Protocols Interface Specification, DPoE-SP-MULPIv2.0, <http://www.cablelabs.com/specification/dpoe-mac-and-upper-layer-protocols-interface-specification/>, Cable Television Laboratories, Inc.
- [DPoE-OAMv2.0] DOCSIS Provisioning of EPON, OAM Extensions Specification, DPoE-SP-OAMv2.0, <http://www.cablelabs.com/specification/dpoe-oam-extensions-specification-2/>, Cable Television Laboratories, Inc.
- [DPoE-OSSIV2.0] DOCSIS Provisioning of EPON, Operations and Support System Interface Specification, DPoE-SP-OSSIV2.0, <http://www.cablelabs.com/specification/dpoe-operations-and-support-system-interface-specification-3/>, Cable Television Laboratories, Inc.
- [DPoE-PHYv2.0] DOCSIS Provisioning of EPON, Physical Layer Specification, DPoE-SP-PHYv2.0, <http://www.cablelabs.com/specification/dpoe-physical-layer-specification-2/>, Cable Television Laboratories, Inc.
- [DPoE-SECV2.0] DOCSIS Provisioning of EPON, Security and Certificate Specification, DPoE-SP-SECV2.0, <http://www.cablelabs.com/specification/dpoe-security-specification/>, Cable Television Laboratories, Inc.
- [DPoE-SOAMv2.0] DOCSIS Provisioning of EPON, DPoE Service-OAM Specification, DPoE-SP-SOAMv2.0, <http://www.cablelabs.com/specification/dpoe-service-oam-specification/>, Cable Television Laboratories, Inc.
- [eDOCSIS] Data-Over-Cable Service Interface Specifications, eDOCSIS Specification, CM-SP-eDOCSIS, <http://www.cablelabs.com/specification/edocsis-specification/>, Cable Television Laboratories, Inc.
- [G.8262/Y.1362] ITU-T Recommendation G.8262/Y.1362, Timing characteristics of a synchronous Ethernet equipment slave clock.
- [ISO/IEC 10589] ISO/IEC 10589:2002, Information technology -- Telecommunications and information exchange between systems -- Intermediate System to Intermediate System intra-domain routing information exchange protocol for use in conjunction with the protocol for providing the connectionless-mode network service (ISO 8473).
- [RFC 826] IETF RFC 826, Ethernet Address Resolution Protocol: Or Converting Network Protocol Addresses to 48.bit Ethernet Address for Transmission on Ethernet Hardware, November 1982.
- [RFC 1997] IETF RFC 1997, BGP Communities Attribute, August 1996.
- [RFC 2080] IETF RFC 2080, RIPng for IPv6, January 1997.
- [RFC 2236] IETF RFC 2236, Internet Group Management Protocol, Version 2, November 1997.
- [RFC 2328] IETF RFC 2328, OSPF Version 2, April 1998.
- [RFC 2385] IETF RFC 2385, Protection of BGP Sessions via the TCP MD5 Signature Option, August 1998.

- [RFC 2402] IETF RFC 2402, IP Authentication Header, November 1998.
- [RFC 2439] IETF RFC 2439, BGP Route Flap Damping, November 1998.
- [RFC 2453] IETF RFC 2453, RIP Version 2, November 1998.
- [RFC 2461] IETF RFC 2461, Neighbor Discovery for IP Version 6 (IPv6), December 1998.
- [RFC 2474] IETF RFC 2474, Definition of Differentiated Services Field (DS Field) in the IPv4 and IPv6 Headers, December 1998.
- [RFC 2545] IETF RFC 2545, Use of BGP-4 Multiprotocol Extensions for IPv6 Inter-Domain Routing, March 1999.
- [RFC 2575] IETF RFC 2575, View-based Access Control Model (VACM) for the Simple Network Management Protocol (SNMP), April 1999.
- [RFC 2710] IETF RFC 2710, Multicast Listener Discovery Version 2 (MLDv2) for IPv6, June 2004.
- [RFC 2863] IETF RFC 2863, The Interfaces Group MIB, June 2000.
- [RFC 2918] IETF RFC 2918, Route Refresh Capability for BGP-4, September 2000.
- [RFC 3031] IETF RFC 3031, Multiprotocol Label Switching Architecture, January 2001.
- [RFC 3032] IETF RFC 3032, MPLS Label Stack Encoding, January 2001.
- [RFC 3101] IETF RFC 3101, The OSPF Not-So-Stubby Area (NSSA) Option, January 2003.
- [RFC 3107] IETF RFC 3107, Carrying Label Information in BGP-4, May 2001.
- [RFC 3270] IETF RFC 3270, Multi-Protocol Label Switching (MPLS) Support of Differentiated Services, May 2002.
- [RFC 3376] IETF RFC 3376, Internet Group Management Protocol, Version 3, October 2002.
- [RFC 3443] IETF RFC 3443, Time To Live (TTL) Processing in Multi-Protocol Label Switching (MPLS) Networks, January 2003.
- [RFC 3478] IETF RFC 3478, Graceful Restart Mechanism for Label Distribution Protocol, February 2003.
- [RFC 3590] IETF RFC 3590, Source Address Selection for the Multicast Listener Discovery (MLD) Protocol, September 2003.
- [RFC 3623] IETF RFC 3623, Graceful OSPF Restart, November 2003.
- [RFC 3769] IETF RFC 3769, Requirements for IPv6 Prefix Delegation, June 2004.
- [RFC 3810] IETF RFC 3810, Multicast Listener Discovery Version 2 (MLDv2) for IPv6, June 2004.
- [RFC 3813] IETF RFC 3813, Multiprotocol Label Switching (MPLS) Label Switching Router (LSR) Management Information Base (MIB), June 2004.
- [RFC 3814] IETF RFC 3814, Multiprotocol Label Switching (MPLS) Forwarding Equivalence Class To Next Hop Label Forwarding Entry (FEC-To-NHLFE) Management Information Base (MIB), June 2004.
- [RFC 3815] IETF RFC 3815, Definitions of Managed Objects for the Multiprotocol Label Switching (MPLS), Label Distribution Protocol (LDP), June 2004.
- [RFC 3971] IETF RFC 3971, SEcure Neighbor Discovery (SEND), March 2005.
- [RFC 4271] IETF RFC 4271, A Border Gateway Protocol 4 (BGP-4), January 2006.
- [RFC 4273] IETF RFC 4273, Definitions of Managed Objects for BGP-4.
- [RFC 4360] IETF RFC 4360, BGP Extended Communities Attribute, February 2006.
- [RFC 4364] IETF RFC 4364, BGP/MPLS IP Virtual Private Networks (VPNs), February 2006.
- [RFC 4379] IETF RFC 4379, Detecting Multi-Protocol Label Switched (MPLS) Data Plane Failures, February 2006.
- [RFC 4385] IETF RFC 4385, Pseudowire Emulation Edge-to-Edge (PWE3) Control Word for Use over an MPLS PSN, February 2006.

- [RFC 4447] IETF RFC 4447, Pseudowire Setup and Maintenance Using the Label Distribution Protocol (LDP), April 2006.
- [RFC 4448] IETF RFC 4448, Encapsulation Methods for Transport of Ethernet over MPLS Networks, April 2006.
- [RFC 4456] IETF RFC 4456, BGP Route Reflection: An Alternative to Full Mesh Internal BGP (IBGP), April 2006.
- [RFC 4601] IETF RFC 4601, Protocol Independent Multicast - Sparse Mode (PIM-SM): Protocol Specification (Revised), August 2006.
- [RFC 4605] IETF RFC 4605, Internet Group Management Protocol (IGMP) / Multicast Listener Discovery (MLD)-Based Multicast Forwarding (IGMP/MLD Proxying), August 2006.
- [RFC 4607] IETF RFC 4607, Source-Specific Multicast for IP, August 2006.
- [RFC 4610] IETF RFC 4610, Anycast-RP Using Protocol Independent Multicast (PIM), August 2006.
- [RFC 4724] IETF RFC 4724, Graceful Restart Mechanism for BGP, January 2007.
- [RFC 4750] IETF RFC 4750, OSPF Version 2 Management Information Base, December 2006.
- [RFC 4760] IETF RFC 4760, Multiprotocol Extensions for BGP-4, January 2007.
- [RFC 4761] IETF RFC 4761, Virtual Private LAN Service (VPLS), Using BGP for Auto-Discovery and Signaling, January 2007.
- [RFC 4762] IETF RFC 4762, Virtual Private LAN Service (VPLS) Using Label Distribution Protocol (LDP) Signaling, January 2007.
- [RFC 4781] IETF RFC 4781, Graceful Restart Mechanism for BGP with MPLS, January 2007.
- [RFC 4822] IETF RFC 4822, RIPv2 Cryptographic Authentication, February 2007.
- [RFC 4862] IETF RFC 4862, IPv6 Stateless Address Autoconfiguration, September 2007.
- [RFC 4893] IETF RFC 4893, BGP Support for Four-octet AS Number Space, May 2007.
- [RFC 4915] IETF RFC 4915, Multi-Topology (MT) Routing in OSPF, June 2007.
- [RFC 4950] IETF RFC 4950, ICMP Extensions for Multiprotocol Label Switching, August 2007.
- [RFC 5036] IETF RFC 5036, LDP Specification, October 2007.
- [RFC 5065] IETF RFC 5065, Autonomous System Confederations for BGP, August 2007.
- [RFC 5082] IETF RFC 5082, The Generalized TTL Security Mechanism (GTSM), October 2007.
- [RFC 5085] IETF RFC 5085, Pseudowire Virtual Circuit Connectivity Verification (VCCV): A Control Channel for Pseudowires, December 2007.
- [RFC 5120] IETF RFC 5120, M-IS-IS: Multi Topology (MT) Routing in Intermediate System to Intermediate system (IS-ISs), February 2008.
- [RFC 5129] IETF RFC 5129, Explicit Congestion Marking in MPLS, January 2008.
- [RFC 5187] IETF RFC 5187, OSPFv3 Graceful Restart, June 2008.
- [RFC 5286] IETF RFC 5286, Basic Specification for IP Fast Reroute: Loop-Free Alternates, September 2008.
- [RFC 5308] IETF RFC 5308, Routing IPv6 with IS-IS, October 2008.
- [RFC 5311] IETF RFC 5311, Simplified Extension of Link State PDU (LSP) Space for IS-IS, February 2009.
- [RFC 5340] IETF RFC 5340, OSPF for IPv6, July 2008.
- [RFC 5443] IETF RFC 5443, LDP IGP Synchronization, March 2009.
- [RFC 5462] IETF RFC 5462, Multiprotocol Label Switching (MPLS) Label Stack Entry: EXP Field Renamed to Traffic Class Field, February 2009.
- [RFC 5796] IETF RFC 5796, Authentication and Confidentiality in Protocol Independent Multicast Sparse Mode (PIM-SM) Link-Local Messages, March 2010.



- [RFC 5838] IETF RFC 5838, Support of Address Families in OSPFv3, April 2010.
- [RFC 5880] IETF RFC 5880, Bidirectional Forwarding Detection, June 2010.
- [RFC 5881] IETF RFC 5881, Bidirectional Forwarding Detection (BFD) for IPv4 and IPv6 (Single Hop), June 2010.
- [RFC 5882] IETF RFC 5882, Generic Application of Bidirectional Forwarding Detection (BFD), June 2010.
- [RFC 5925] IETF RFC 5925, The TCP Authentication Option, June 2010.
- [RFC 5952] IETF RFC 5952, A Recommendation for IPv6 Address Text Representation, August 2010.
- [RFC 6074] IETF RFC 6074, Provisioning, Auto-Discovery, and Signaling in Layer 2 Virtual Private Networks (L2VPNs), January 2011.
- [RFC 6138] IETF RFC 6138, LDP IGP Synchronization for Broadcast Networks, February 2011.
- [RFC 6178] IETF RFC 6178, Label Edge Router Forwarding of IPv4 Option Packets, March 2011.
- [RFC 6213] IETF RFC 6213, IS-IS BFD-Enabled TLV, April 2011.
- [RFC 6391] IETF RFC 6391, Flow-Aware Transport of Pseudowires over an MPLS Packet Switched Network, November 2011.

## 2.2 Informative References

This specification uses the following informative references.

- [802.1ag] IEEE Std 802.1ag™-2007, IEEE Standard for Local and metropolitan Area Networks – Virtual Bridged Local Area Networks Amendment 5: Connectivity Fault Management, December 2007.
- [802.1ax] IEEE Std 802.1ax™-2008, IEEE Standard for Local and Metropolitan Area Networks-Link Aggregation, January 2008.
- [DOCSIS] Refers to DOCSIS 3.0 unless otherwise specified.
- [eRouter] Data-Over-Cable Service Interface Specifications, eRouter Specification, CM-SP-eRouter, <http://www.cablelabs.com/specification/ipv4-and-ipv6-erouter-specification/>, Cable Television Laboratories, Inc.
- [G.805] ITU-T Recommendation G.805 (03/2000), Generic functional architecture of transport networks.
- [IPFIX] IETF Requirements for IP Flow Information Export (IPFIX)  
<http://datatracker.ietf.org/wg/ipfix/chrter/>.
- [L2VPN] Data-Over-Cable Service Interface Specifications, Layer 2 Virtual Private Networks, CM-SP-L2VPN, <http://www.cablelabs.com/specification/business-services-over-docsis-layer-2-virtual-private-networks/>, Cable Television Laboratories, Inc.
- [MEF 6] Metro Ethernet Forum, MEF 6.1 Ethernet Services Definitions, Phase 2, April 2008.
- [MEF 9] Metro Ethernet Forum, Abstract Test Suite for Ethernet Services at the UNI, October 2004.
- [MEF 14] Metro Ethernet Forum, Abstract Test Suite for Traffic Management Phase 1, November 2005.
- [MEF 21] Metro Ethernet Forum, Service OAM and Requirements Framework, Phase 1, April 2007.
- [MEF 26] Metro Ethernet Forum, External Network to Network Interface (ENNI) – Phase 1, January 2010.
- [MULPIv3.0] Data-Over-Cable Service Interface Specifications, MAC and Upper Layer Protocols Interface Specification, <http://www.cablelabs.com/specification/mac-and-upper-layer-protocols-interface-specification/>, CM-SP-MULPIv3.0, Cable Television Laboratories, Inc.
- [NETCONF] IETF, Network Configuration Working Group (NETCONF)  
<http://datatracker.ietf.org/wg/netconf/charter/>.
- [OSSIV3.0] Data-Over-Cable Service Interface Specifications, Operations Support System Interface Specification, CM-SP-OSSIV3.0, <http://www.cablelabs.com/specification/docsis-3-0-operations-support-system-interface-specification/>, Cable Television Laboratories, Inc.

- [PHYv3.0] Data-Over-Cable Service Interface Specifications, Physical Layer Specification, CM-SP-PHYv3.0, <http://www.cablelabs.com/specification/docsis-3-0-physical-layer-interface-specification/>, Cable Television Laboratories, Inc.
- [SCTE 174] ANSI/SCTE 174 2010, Radio Frequency over Glass Fiber-to-the-Home Specification.
- [SECv3.0] Data-Over-Cable Service Interface Specifications, Security Specification, CM-SP-SECv3.0, <http://www.cablelabs.com/specification/docsis-3-0-security-specification/>, Cable Television Laboratories, Inc.
- [SFF-8077i] SFF-8077i 10 Gigabit Small Form Factor Pluggable Module, Revision 4.0, released April 13, 2004.
- [SFF-8472] SFF-8472 Specification for Diagnostic Monitoring Interface for Optical Transceivers, Revision 10.4, released January 2009.
- [SFP MSA] INF 8074i Rev 1.0, Small Form-factor Pluggable Multi-Source Agreement, released 12 May, 2001.

## 2.3 Reference Acquisition

- Cable Television Laboratories, Inc., 858 Coal Creek Circle, Louisville, CO 80027; Phone +1-303-661-9100; Fax +1-303-661-9199; <http://www.cablelabs.com>
- Internet Engineering Task Force (IETF) Secretariat, 48377 Fremont Blvd., Suite 117, Fremont, California 94538, USA, Phone: +1-510-492-4080, Fax: +1-510-492-4001, <http://www.ietf.org>
- Institute of Electrical and Electronics Engineers (IEEE), +1 800 422 4633 (USA and Canada); <http://www.ieee.org>
- ITU: International Telecommunications Union (ITU), <http://www.itu.int/home/contact/index.html>
- MEF: Metro Ethernet Forum, 6033 W. Century Blvd, Suite 830, Los Angeles, CA 90045  
Phone +1-310-642-2800; Fax +1-310-642-2808. Internet: <http://metroethernetforum.org>
- SCTE, Society of Cable Telecommunications Engineers Inc., 140 Philips Road, Exton, PA 19341  
Phone: +1-800-542-5040, Fax: +1-610-363-5898, Internet: <http://www.scte.org/>
- Small Form Factor Committee (SFF), <http://www.sffcommittee.com>

## 3 TERMS AND DEFINITIONS

### 3.1 DPoE Network Elements

<b>DPoE Network</b>	This term means all the elements of a DPoE implementation, including at least one DPoE System, one or more D-ONUs connected to that DPoE System, and possibly one or more DEMARCs
<b>DPoE System</b>	This term refers to the set of subsystems within the hub site that provides the functions necessary to meet DPoE specification requirements.
<b>D-ONU (D-ONU)</b>	This term means a DPoE-capable ONU that complies with all the DPoE specifications. There are two logical types of D-ONUs. These are the DPoE Standalone ONU (S-ONU) and the DPoE Bridge ONU (B-ONU). Requirements specified for a D-ONU must be met by all ONUs.
<b>DPoE Standalone ONU (S-ONU)</b>	This term means a D-ONU that provides all the functions of a B-ONU and also provides at least one CMCI port. An S-ONU can optionally have one or more eSAFEs.
<b>DPoE Bridge ONU (B-ONU)</b>	This term means a D-ONU that is capable of [802.1] forwarding but cannot do all the encapsulation functions required to be an S-ONU. The B-ONU is a logical definition used by the specification for requirements that apply to all types of B-ONUs. The two types of B-ONUs are the BP-ONU and the BB-ONU.
<b>DPoE Bridge Baseband ONU (BB-ONU)</b>	This term means a D-ONU that is a B-ONU which has a baseband IEEE Ethernet interface. BB-ONUs include those with one or more [802.3] baseband PMDs. (See [DPoE-MULPIv2.0] for examples.)
<b>DPoE Bridge Pluggable ONU (BP-ONU)</b>	This term means a D-ONU that is a B-ONU which is pluggable. Pluggable BP-ONUs include devices such as an SFP-ONU (1G-EPON), SFP+ONU (10G-EPON), or XFP-ONU (10G-EPON).
<b>DEMARC</b>	Short form of "Demarcation Device." This term means the device, owned and operated by the operator that provides the demarcation (sometimes called the UNI interface) to the customer. Some architectures describe this device as the CPE (as in DOCSIS) or the NID (as in the MEF model).

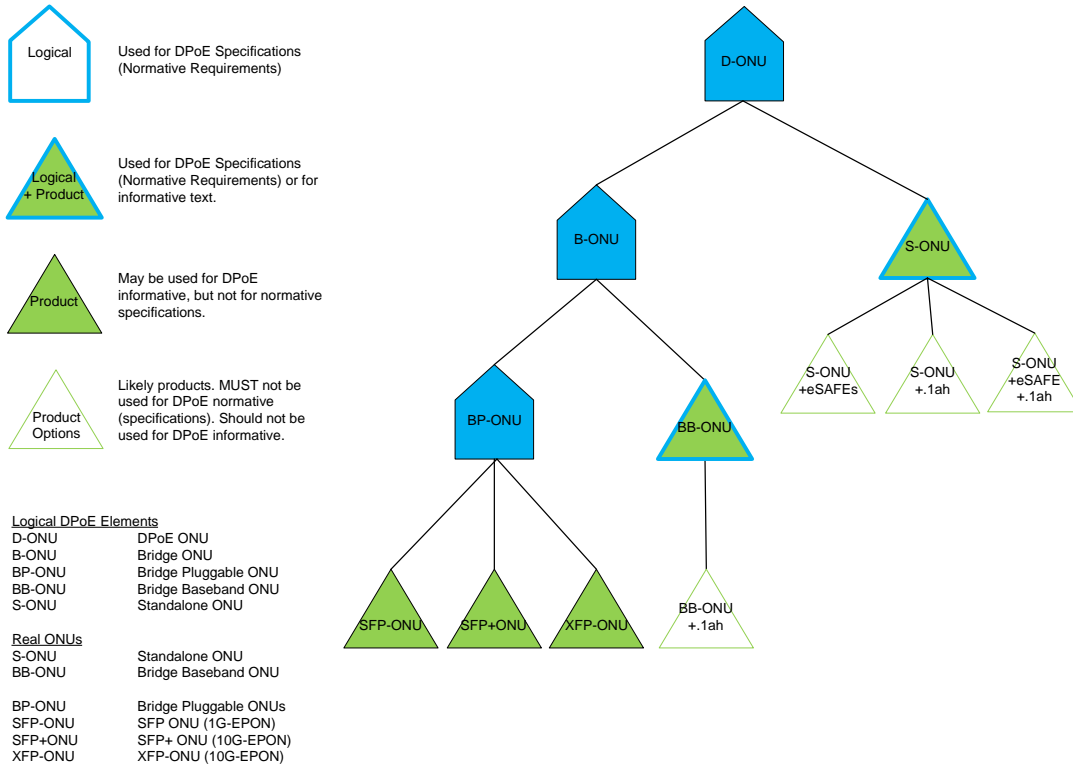

Figure 3 - D-ONU Types

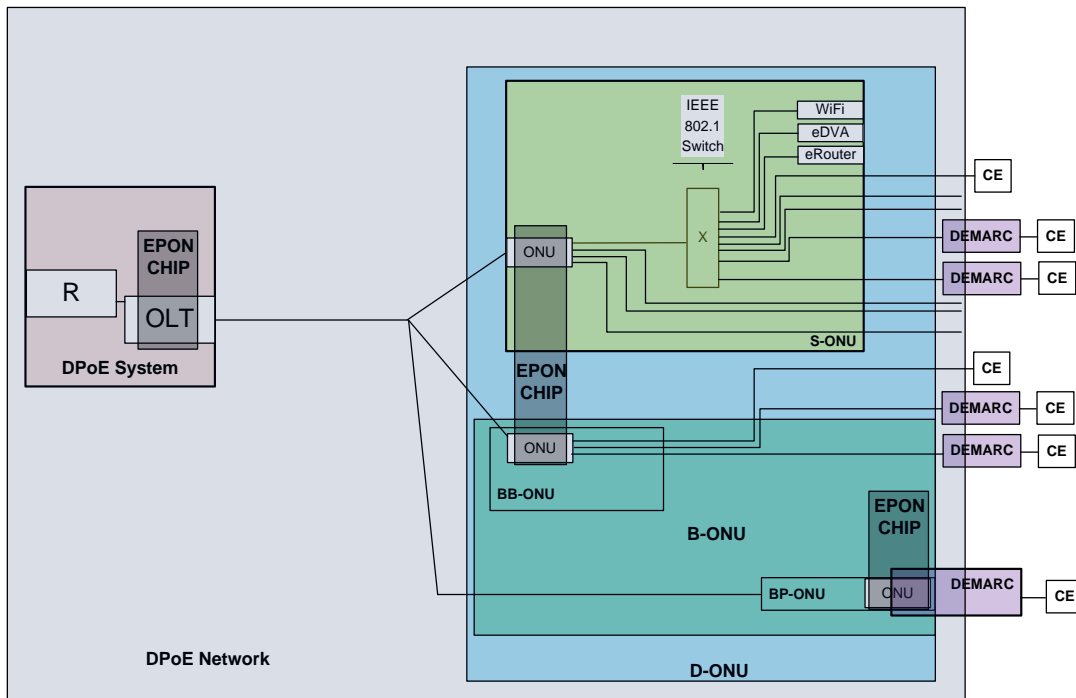

Figure 4 - DPoE Network Elements

## 3.2 Other Terms and Definitions<sup>5</sup>

<b>1G-EPON</b>	EPON as defined in [802.3ah], now part of [802.3].
<b>2G-EPON</b>	EPON as defined in Annex A 2G-EPON System Definition of [DPoE-PHYv2.0]
<b>10G-EPON</b>	EPON as defined in [802.3av], now part of [802.3].
<b>Address Resolution Protocol</b>	A protocol of the IETF for converting network addresses to 48-bit Ethernet addresses.
<b>Byte</b>	A contiguous sequence of eight bits. An octet.
<b>Burst</b>	A single, continuous transmission in the upstream direction originating from a single ONU, where queued customer data is transmitted towards the DPoE System at the full data rate supported by the transmission channel. Between bursts, ONUs do not transmit any data.
<b>Cable Modem CPE Interface</b>	CMCI as defined in [MULPIv3.0].
<b>Classifier</b>	A set of criteria used for packet matching according to TCP, UDP, IP, LLC, [802.1D] priority field or [802.1Q] packet fields. A classifier maps each packet to a Service Flow. A Downstream classifier is used by the DPoE System to assign packets to downstream service flows. An Upstream classifier is used by The D-ONU to assign packets to upstream service flows.
<b>Codeword</b>	An element of an error-correcting code used to detect and correct transmission errors.
<b>Customer Premise Equipment (CPE)</b>	Customer Premise Equipment as defined in [DOCSIS].
<b>Data Link Layer</b>	Layer 2 in the Open System Interconnection (OSI) architecture; the layer that provides services to transfer data over the transmission link between open systems (here, equal to EPON).
<b>Data Rate</b>	Rate Throughput, data transmitted in units of time usually in bits per second (bps). Various multipliers are used in this document, ranging from kbit/s (thousand bits per second) to Gbps (billion bits per second).
<b>EPON Operations and Maintenance Messaging (OAM)</b>	EPON OAM messaging as defined in [802.3] and [DPoE-OAMv2.0]; Ethernet OAM is not the same as EPON OAM; Ethernet OAM is defined in [802.1ag].
<b>Ethernet Passive Optical Network (EPON)</b>	Refers to both 1G-EPON and 10G-EPON collectively.
<b>Frame</b>	Basic data organizational unit. Here, equal to MAC frame per [802.3], Clause 4.
<b>Logical CPE Interface</b>	LCI as defined in [eDOCSIS].
<b>Network Interface Device (NID)</b>	A DEMARC device in DPoE specifications.
<b>TRAN-trail</b>	A TRAN-trail (see ITU-T Recommendation [G.805]) is a "transport entity" responsible for the transfer of information from the input of a trail termination source to the output of a trail termination sink.
<b>Upstream</b>	The direction of transmission from the customer to the headend.

<sup>5</sup> Revised per IPNEv2.0-N-14.0170-1 and IPNEv2.0-N-14.0186-1 on 7/11/14 by JB.

## 4 ABBREVIATIONS AND ACRONYMS <sup>6</sup>

This specification uses the following abbreviations:

<b>1G-EPON</b>	EPON as defined in [802.3ah], now part of [802.3]
<b>10G-EPON</b>	EPON as defined in [802.3av], now part of [802.3]
<b>ACL</b>	Access Control Lists
<b>ALG</b>	Application Layer Gateway
<b>ARP</b>	Address Resolution Protocol
<b>ASCII</b>	<b>American Standard Code for Information Exchange</b>
<b>BFD</b>	<b>Bi-directional Forwarding Detection</b>
<b>BGP</b>	<b>Border Gateway Protocol</b>
<b>BOOTP</b>	<b>Bootstrap Protocol</b>
<b>BPS</b>	<b>Bits Per Second</b>
<b>CFM</b>	<b>Connectivity Fault Management</b>
<b>CLI</b>	<b>Command Line Interface</b>
<b>CM</b>	<b>Cable Modem</b>
<b>CMCI</b>	<b>Cable Modem CPE Interface</b>
<b>CMTS</b>	<b>Cable Modem Termination System</b>
<b>CPE</b>	<b>Customer Premise Equipment</b>
<b>CoS</b>	<b>Class of Service</b>
<b>DAC</b>	<b>DEMARc Auto-Configuration</b>
<b>DHCP</b>	<b>Dynamic Host Configuration Protocol</b>
<b>DNS</b>	<b>Domain Name Service</b>
<b>DOCSIS</b>	<b>Data Over Cable Service Interface Specification</b>
<b>DPoE</b>	<b>DOCSIS Provisioning of EPON</b>
<b>DR</b>	<b>Default Router</b>
<b>DSCP</b>	<b>Diff-Serv Code Point</b>
<b>DSG</b>	<b>DOCSIS Set-top Gateway</b>
<b>EACL</b>	<b>Extended Access Control Lists</b>
<b>eCM</b>	<b>embedded Cable Modem</b>
<b>ECMP</b>	<b>Equal Cost Multi-path</b>
<b>FEC</b>	<b>Forward Error Correction</b>
<b>FQDN</b>	<b>Fully Qualified Domain Name</b>
<b>FTP</b>	<b>File Transfer Protocol</b>
<b>IEEE</b>	<b>Institute of Electrical and Electronics Engineers</b>
<b>IETF</b>	<b>Internet Engineering Task Force</b>
<b>EPON</b>	<b>Ethernet Passive Optical Network</b>
<b>eSAFE</b>	<b>embedded Service/Application Functional Entity</b>
<b>FRR</b>	<b>Fast Reroute</b>

<sup>6</sup> Revised per IPNEv2.0-N-14.0170-1 on 7/11/14 by JB.

<b>FTP</b>	<b>File Transfer Protocol</b>
<b>GTSM</b>	<b>Generalized TTL Security Mechanism</b>
<b>HSD</b>	<b>High Speed Data</b>
<b>HTTP</b>	<b>Hypertext Transfer Protocol</b>
<b>Gbps</b>	<b>Gigabits per second (as used in the industry)</b>
<b>IBGP</b>	<b>Interior Border Gateway Protocol</b>
<b>IGP</b>	<b>Interior Gateway Protocols</b>
<b>IP(HSD)</b>	<b>High Speed Data (Broadband Internet Access using DOCSIS)</b>
<b>INNI</b>	<b>Internal Network to Network Interface</b>
<b>IP</b>	<b>Internet Protocol</b>
<b>IP-SG</b>	<b>IP Serving Group</b>
<b>I-SID</b>	<b>[802.1Q] I-Component Service IDentifier</b>
<b>IS-IS</b>	<b>Intermediate System to Intermediate System</b>
<b>L2VPN</b>	<b>Layer 2 Virtual Private Networks</b>
<b>LACP</b>	<b>Link Aggregation Control Protocol</b>
<b>LACPDU</b>	<b>Link Aggregation Control Protocol Data Unit</b>
<b>LAG</b>	<b>Link Aggregation</b>
<b>LCI</b>	<b>Logical CPE Interface</b>
<b>LDP</b>	<b>Label Distribution Protocol</b>
<b>LDP-FEC</b>	<b>Label Distribution Protocol Forward Equivalence Class</b>
<b>LLID</b>	<b>Logical Link Identifier</b>
<b>LOM</b>	<b>Lights Out Management</b>
<b>LSA</b>	<b>Link State Advertisement</b>
<b>MAC</b>	<b>Media Access Control</b>
<b>MEF</b>	<b>Metro Ethernet Forum</b>
<b>MEN</b>	<b>Metro Ethernet Network</b>
<b>MI</b>	<b>MEF INNI Interface at a customer premise</b>
<b>mLDP</b>	<b>Multicast Label Distribution Protocol</b>
<b>MLS</b>	<b>Multi-Layer Switching</b>
<b>MN</b>	<b>MEF INNI Interface to operators MEN</b>
<b>MOTD</b>	<b>Message Of The Day</b>
<b>MPLS</b>	<b>Multi-protocol Label Switching</b>
<b>MSA</b>	<b>Multi-source Agreement</b>
<b>MU</b>	<b>MEF UNI Interface</b>
<b>NE</b>	<b>Network Elements</b>
<b>NEBS</b>	<b>Network Equipment Building Standard</b>
<b>NID</b>	<b>Network Interface Device</b>
<b>NNI</b>	<b>Network to Network Interface</b>
<b>NTP</b>	<b>Network Time Protocol</b>
<b>OAM</b>	<b>EPON Operations Administration and Maintenance</b>
<b>OAMP</b>	<b>Operations Administration Maintenance and Provisioning</b>

<b>ODN</b>	<b>Optical Distribution Network</b>
<b>OID</b>	<b>Object Identifier</b>
<b>OLT</b>	<b>Optical Line Termination</b>
<b>ONU</b>	<b>Optical Network Unit</b>
<b>OSC</b>	<b>Optical Splitter Combiner</b>
<b>OSPF</b>	<b>Open Shortest Path First</b>
<b>PB</b>	<b>Provider Bridging</b>
<b>PBB</b>	<b>Provider Backbone Bridging</b>
<b>PCMM</b>	<b>Packet Cable Multimedia</b>
<b>PDU</b>	<b>Protocol Data Unit</b>
<b>PHY</b>	<b>Physical Layer</b>
<b>PIM</b>	<b>Protocol Independent Multicast</b>
<b>PIM-SM</b>	<b>Protocol Independent Multicast – Sparse Mode</b>
<b>PON</b>	<b>Passive Optical Network</b>
<b>PPP</b>	<b>Point to Point Protocol</b>
<b>PPS</b>	<b>Packets Per Second</b>
<b>QoS</b>	<b>Quality of Service</b>
<b>R</b>	<b>IP Router</b>
<b>RADIUS</b>	<b>Remote Authentication Dial In User Service</b>
<b>RF</b>	<b>Radio Frequency</b>
<b>RFoG</b>	<b>Radio Frequency over Glass</b>
<b>RIP</b>	<b>Routing Information Protocol</b>
<b>sDVA</b>	<b>Standalone Digital Voice Adapter</b>
<b>SCP</b>	<b>Secure Copy</b>
<b>SFP</b>	<b>Small Form-factor Pluggable</b>
<b>SFP+</b>	<b>Small Form-factor Pluggable Plus (+)</b>
<b>SFTP</b>	<b>Secure Shell File Transfer Protocol</b>
<b>SG</b>	<b>Serving Group</b>
<b>SLARP</b>	<b>Serial Line Address Resolution Protocol</b>
<b>SLIP</b>	<b>Serial Line Internet Protocol</b>
<b>SNMP</b>	<b>Simple Network Management Protocol</b>
<b>SSH</b>	<b>Secure Shell</b>
<b>SSM</b>	<b>Source Specific Multicast</b>
<b>Tbps</b>	<b>Terrabit per second</b>
<b>TC</b>	<b>Traffic Class</b>
<b>TFTP</b>	<b>Trivial File Transfer Protocol</b>
<b>TOS</b>	<b>Terms Type of Service</b>
<b>TACACS+</b>	<b>Terminal Access Controller Access-Control System Plus</b>
<b>TPID</b>	<b>Tag Protocol Identifier</b>
<b>ULL</b>	<b>Underwriter Laboratory Listing</b>
<b>UNI</b>	<b>User Network Interface</b>



<b>URI</b>	<b>Uniform Resource Identifier</b>
<b>UTC</b>	<b>Coordinated Universal Time</b>
<b>vCM</b>	<b>Virtual Cable Modem</b>
<b>VLAN</b>	<b>Virtual Local Area Network</b>
<b>VLSM</b>	<b>Variable Length Subnet Masking</b>
<b>VPLS</b>	<b>Virtual Private LAN Service</b>
<b>VPWS</b>	<b>Virtual Private Wire Service</b>
<b>X</b>	<b>IEEE Ethernet Switch (Generic)</b>
<b>XFP</b>	<b>X Form-factor Pluggable</b>
<b>XML</b>	<b>Extensible Markup Language</b>

## 5 IPNE FUNCTIONS (INFORMATIVE)

Existing [DOCSIS]-based CMTSs have a number of functions that are necessary, and which are not specified or explained in the [DOCSIS] or DPoE Specifications. This section provides the rationale and description of the functions required by CMTS and DPoE Systems.

The [DOCSIS] specifications provide a set of standards to ensure interoperability between Cable Modems (CM) and Cable Modem Termination Systems (CMTS). The [DOCSIS] specifications place requirements on and capabilities for the DOCSIS interfaces and the operations, administration, maintenance, and provisioning (OAMP) of CMs so that any operator's systems and any CMTS can operate any CM.

The [DOCSIS] specifications contain requirements for some aspects of CMTS OAMP. These are focused primarily on the interoperability described above. However, [DOCSIS] requirements are silent on the forwarding and signaling architecture for both Ethernet and IP NNI interface that connect the CMTS to the operator's Ethernet and IP networks. [DOCSIS] also provides some minimal requirements for the management of the CMTS entity, but is again silent on entity requirements.

Over their years of experience, cable operators have developed product requirements for their CMTS vendors. This document collects a number of these standard features and places them in the context of standard requirements against the DPoE System. In addition, this document includes new DPoE-specific requirements to provide a baseline of standard product capabilities.

## 6 DPOE SYSTEM IPNE REQUIREMENTS

DOCSIS specifications do not describe the configuration of the CMTS. The DPoE specifications (not including this specification) only identify requirements for the DPoE System but they do not specify methods of configuring the DPoE System. This document specifies only those (missing) requirements not otherwise specified.

### 6.1 Network Element Access Methods and Operations

#### 6.1.1 Command Line Interface

The DPoE System MUST have a Command Line Interface (CLI). The DPoE System MUST have a serial port terminal for the management and operation of the complete DPoE System. The DPoE System MUST make the CLI accessible from a serial port terminal and from configurable IP loopback addresses using the SSH2 protocol. The DPoE System CLI is expected to be identical CLI whether accessed via terminal / serial interface or IP via SSH2. The DPoE System MUST have the capability to support Access Control Lists (ACLs) and Extended Access Control Lists (EACLs) to limit the connection of clients to the SSH2 daemon by source IP address.

The DPoE System CLI is expected to provide a structured command syntax format for input and output in order to support scripting.

The DPoE System CLI MUST provide context sensitive help. The DPoE System SHOULD provide command interactive command completion using the ASCII TAB character when the existing portion of an entered command is unique and can be completed without further information typed, sent or read into the CLI parser.

The DPoE System CLI MUST support a configurable idle-timer to automatically log off clients.

The DPoE System CLI MUST provide a capability to list all clients connected to the CLI (by any means available). The DPoE System CLI MUST provide a method to disconnect selected clients connected to the CLI.

The DPoE System CLI prompt MUST be operator configurable.

The DPoE System MUST support CLI access from any means for at least four (4) sessions simultaneously. The DPoE System MUST support simultaneous access for users with different privileges. The DPoE System MUST allow at least four (4) simultaneous CLI users to enter an active configuration mode simultaneously and enter real-time configuration changes or make changes to a configuration file. The DPoE System MUST inform each connected CLI user that another user has connected to the CLI or been disconnected from the CLI. The DPoE System MUST inform each connected CLI user that another user has entered a configuration mode when in the CLI.

The DPoE System MUST log (if enabled) commands entered from any active CLI connection to a log file. Each DPoE System command log file entry MUST contain the exact command as entered, a time and date stamp, and the login identification used by the operator that entered the command. The DPoE System SHOULD maintain a history of at least the last ten commands entered commands per CLI session. This command history is associated to the CLI session. When the CLI session is ended, the DPoE System is expected to remove the history for that CLI session.

#### 6.1.2 Terminal Access

The DPoE System MUST support VT100 terminal access via serial port with RJ-45 or RS-232 connectors to the CLI.

The DPoE System MAY have more than one port for terminal access. If the DPoE System has more than one port for terminal access, all terminal access ports are expected to provide identical functionality.

#### 6.1.3 Lights Out Management

The DPoE System MAY provide Ethernet-based Lights Out Management (LOM) interface which may use Serial Line Address Resolution Protocol (SLARP), SLIP, PPP, or other means of automatic IP address and IP network configuration to provide console or terminal access.

The DPoE System that optionally provides LOM access MUST provide full CLI access via LOM interface to the DPoE System. The DPoE System MAY have more than one port for LOM. If the DPoE System has more than one LOM port, all LOM ports MUST provide identical functionality.

#### 6.1.4 Secure Login

The DPoE System **MUST** support non-encrypted password access via Telnet if configured.

The DPoE System **MUST** support MD5 encrypted storage of passwords for CLI access (by any means) if configured.

The DPoE System **MUST** support encrypted password access via SSH2 if configured.

The DPoE System **MUST** support Remote Authentication Dial In User Service (RADIUS) for password authentication if configured.

The DPoE System **MUST** support Terminal Access Controller Access-Control System Plus (TACACS+) for password authentication if configured.

The DPoE System **MUST** support at least two (2) operating RADIUS or two (2) operating TACACS+ servers. At any time, only one of operating authentication servers is expected to be active. The DPoE System is expected to be able to forward authentication requests to the currently active authentication server. The details of how DPoE System tracks authentication server status and selects the authentication server to send authentication requests to are outside the scope of this specification.

The DPoE System **MUST** provide a local method for password recovery for passwords stored on the DPoE System. The DPoE System LOM or serial port **MUST** allow access to the password recovery method. The DPoE System **MUST NOT** allow access to the password recovery method over the D, MN, or TU interfaces.

The DPoE System **SHOULD** provide a method to configure (from the CLI and in the configuration file) the DPoE System to limit access to each and every CLI command and each and every configuration command based on the type of secure login (SSH2, RADIUS, TACACS+, Telnet, or local), the operator name (username), and the time of day.

#### 6.1.5 Client Applications

The DPoE System **MUST** provide a Telnet client. The DPoE System **MUST** provide an SSH2 client. The purpose of this functionality is to allow operators logged into a DPoE System to login to another system (DPoE System, CMTS, server, eRouter, eDVA etc.) from the DPoE System.

The DPoE System **MUST** act as a DNS client. The DPoE System **MUST** be configurable to support at least two (2) DNS servers configured by IPv4 address in the configuration file. The DPoE System **MUST** be configurable to support at least two (2) DNS servers configured by IPv6 address in the configuration file.

The DPoE System **MUST** act as an NTP client. The DPoE System **MUST** be configurable to support at least two (2) NTP servers configured by IPv4 address in the configuration file. The DPoE System **SHOULD** be configurable to support at least two (2) NTP servers configured by IPv6 address in the configuration file.

#### 6.1.6 Command Logging

The DPoE System **MUST** provide a means (in the configuration file and at the command line) to enable and disable command logging. The DPoE System **MUST** provide a means to limit the capability to enable and disable command logging to specifically authorized operators based on the login identification.

The DPoE System **MUST** log (if enabled) commands entered from any active CLI connection to configured TACACS+ server (TACACS+ Accounting.) Each DPoE System TACACS+ command log entry **MUST** contain the exact command as entered, a time and date stamp, and the login identification used by the operator that entered the command.

The DPoE System **SHOULD** be capable of displaying entries from the command log, as described above; sorted by any combination of: login identification (name), date, and time.

The DPoE System **MAY** be capable of displaying entries from the command log, as described above; sorted or filtered by classes or categories of command as defined by the DPoE System vendor.

### 6.1.7 XML Management

- The DPoE System MAY support XML-based management. The DPoE System MAY support XML-based management using:XML Configuration Files
- XML/SOAP over HTTP
- XML/SOAP over RSH
- XML with other access methods

If a DPoE System supports XML-based management, it SHOULD have a published XML API using a well-known object architecture such as [NETCONF] custom SOAP objects, etc.

### 6.1.8 Power Saving<sup>7</sup>

If the DPoE System supports the power saving mechanism, the DPoE System MUST provide a CLI mechanism to control the following aspects of the power saving mechanism:

- if the power saving mechanism is supported on the given TU interface, enable / disable the power saving mechanism on the selected TU interface. The example of the respective command is shown below:

```
CLI# power-save cable modem interface <tu> enable / disable
```

- if the power saving mechanism is enabled on the given TU interface and the power saving mechanism is supported for the given ONU (vCM), enable / disable the power saving mechanism for the selected ONU (vCM) instance,

```
CLI# power-save cable modem <mac> enable / disable
```

- if the power saving mechanism is enabled for the given ONU (vCM) is enabled, configure the parameters of the power saving mechanism, including the maximum duration of the sleep cycle, target sleep mode for the ONU, etc.

```
CLI# power-save cable modem <mac> cycle-length <ms>
```

```
CLI# power-save cable modem <mac> sleep-mode <type>
```

### 6.1.9 SNMP

The DPoE System MUST provide a unique text (string) description for the DPoE System in the object:  
.1.3.6.1.2.1.1.0.iso.org.dod.internet.mgmt.mib.system.sysDescr.0.

The DPoE System MUST provide a chassis serial number for each DPoE System chassis. The DPoE System serial number MUST NOT be operator configurable. The DPoE System MUST provide access to the chassis serial number for each chassis in the DPoE System by SNMP.

The DPoE System MUST support [RFC 4273] BGP-4 MIB for the DPoE System and D Interface.

The DPoE System MUST support [RFC 4750] OSPF traps for the DPoE System and D interface.

- The DPoE System MUST provide an industry standard or vendor-specific MIB to provide the following information:
  - Memory utilization
  - CPU utilization
  - Hardware version for all DPoE System components that are modular (chassis, blades, servers, line cards, shelves, power supplies, etc.)
  - Firmware version for all DPoE System components that are modular (chassis, blades, servers, line cards, shelves, power supplies, etc.)

<sup>7</sup> Revised per IPNEv2.0-N-14.0197-1 on 11/18/2014 by JB.

- Software version for all DPoE System components that are modular (chassis, blades, servers, line cards, shelves, power supplies, etc.)
- Fail over notifications for all redundant elements (processors, switches, fabrics, line cards, servers, ports, interfaces, power supplies, etc.)

The DPoE System **MUST** support at least two (2) community strings for read-only. The DPoE System **MUST** support at least two (2) community strings for read-write (RW) that are distinct from the RO community strings.

The DPoE System **SHOULD** provide a method to separately limit or block each of both read and write access to MIB objects by OID based on the received community string for each SNMP message otherwise known as the view-based access control model for SNMP [RFC 2575].

The DPoE System **MUST** support at least two (2) SNMP trap destination (servers or IP addresses). The DPoE System **MAY** support configuring the SNMP trap UDP port number for each trap destination.

The DPoE System **SHOULD** provide a method to individually enable and disable each possible trap required by this specification. The DPoE System **SHOULD** provide a method to assign a severity level for each possible trap.

The DPoE System **MUST** have the capability to enable persistent ifIndexes such that the interface index (when the feature is enabled) is persistent across a DPoE System reboot.

## 6.2 Messages

The DPoE System uses messages to all active login sessions to provide a method of notification to all active sessions. The DPoE System **MUST** provide a message to all active login sessions and create a matching local log entry for each of the following events:

- Configuration change is committed or saved
- An interface is administratively configured up or down
- A new session is started (logged in) or ended (logged out)
- An attempt to login fails

The DPoE System **SHOULD** support the capability to configure the DPoE System to provide messages to all active login sessions and a matching local log entry for all configuration changes and state changes. The DPoE System **MAY** offer the capability to turn on or turn off specific verbose messaging and logging capabilities in addition to the all on or all off capability.

The DPoE System **MUST** provide a warning message to an active login session when that session enters an interactive configuration mode where changes entered can affect the configuration currently in use.

## 6.3 System Configuration File

The DPoE System **MUST** provide a method for the transfer, storage, use, editing, and manipulation of a human-readable configuration file for the entire DPoE System as a single contiguous configuration file.

The DPoE System **MAY** use an XML format configuration file such as that described in [NETCONF]. The DPoE System **SHOULD** provide a method to designate a configuration file as the next active configuration file. The DPoE System **SHOULD** provide a separate method to activate the currently designated configuration file to load and run the system.

The DPoE System **SHOULD** provide a method for storage of a previous configuration (for roll-back or back-out) when configuration changes are made interactively or by file transfer.

The DPoE System **SHOULD** provide a complete revision control system for making, accepting, and providing comments on revision of configuration files.

The DPoE System **SHOULD** provide a method to compare the current (active) configuration and the immediate (previous) configuration, displaying the differences between the two files.

The DPoE System SHOULD provide a method to compare any two stored or saved configuration files, displaying the differences between the two files.

The DPoE System MUST provide a method to edit configuration files at the terminal of the device and over the SSH2 interface that is operable with a text based terminal or terminal window.

## 6.4 DPoE System Executable Software (Images)

The DPoE System MUST operate as a single IP network element such that a single binary software image can be transferred to the system to provide the executable (binary) software image for the entire DPoE System.

The DPoE System executable (binary) software image MAY consist of various modules or other segments of code that the DPoE System can parse and use to manage the software of sub-systems within the DPoE System.

### 6.4.1 System Image Storage and Control

The storage capacity on the DPoE System should be sufficient to store the active DPoE System executable software (image) currently running and at least two other versions of the software. This functionality is useful to allow the operator to rollback or back-out the software to a previous version and download newer versions for software upgrades.

The DPoE System MUST have the capability for the operator to designate which of the available software images to load on the next reboot from among the available software images. As part of the software release program, each published version of the DPoE System executable software (image) needs to include a separate file containing the corresponding MD5 hash computed against the executable image. The DPoE System MUST provide a command to read and compute an MD5 hash from the executable software (image) stored on the DPoE System and compare it to the corresponding MD5 key. The DPoE System MAY run this same executable software (image) file validation against an executable software (image) immediately before loading or running the image.

## 6.5 File Transfer

The DPoE System MUST include an SSH File Transfer Protocol (SFTP) [draft-ietf-secsh-filexfer-13] client to transfer files from an SFTP server. The DPoE System SHOULD support the transfer of a file via a single-line SFTP command. The DPoE System MUST include an SFTP server to receive files from an SFTP client. The DPoE System MUST provide the capability to enable or disable the local SFTP Server.

The DPoE System MUST include an FTP client to transfer files from an FTP server. The DPoE System SHOULD support the transfer of a file via a single-line FTP command. The DPoE System MUST include an FTP server to receive files from an FTP client. The DPoE System CLI MUST provide the capability to enable or disable the local FTP Server.

The DPoE System MUST include a Secure Copy (SCP) client to transfer files from an SCP server to the DPoE System. The DPoE System SHOULD support the transfer of a file via a single-line SCP command.

## 6.6 File Storage and Control

The DPoE System SHOULD store configuration files in an ASCII or UTF-8 formatted file.

### 6.6.1 Integrated

The DPoE System is expected to have integrated (or built-in) storage for configuration files, executable software (images) files, and local log files.

The DPoE System is expected to have sufficient storage capacity to store the active DPoE System configuration file currently running and at least three other configurations for the DPoE System. This functionality is required in order to allow the operator to back-out the configuration to a previous configuration and download, edit, or create new configurations.

The DPoE System is expected to have sufficient storage capacity to store the system configuration files as described above, all local logs, and any crash files, core dumps, or other diagnostic data. As described below, operators can adjust the size of the log files to limit the space required for the potentially unbounded resource demands of logs.

### 6.6.2 Pluggable Storage

The DPoE System SHOULD support a pluggable storage medium capable of the same file storage and control as the integrated file storage and control described above. USB, PCMCIA Flash, Compact Flash, or other non-volatile memory could be used for such storage.

### 6.6.3 Local Log

The DPoE System uses local log as specified in [DPoE-OSSIV2.0].

## 6.7 Logs

On the DPoE System there are requirements for log space to store vCM log events and requirements for log space to store DPoE System log events – hardware, software, and network interface failures – referred to as "platform logs". The DPoE System MUST log all platform logs in a local log that physically resides on the DPoE System. The DPoE System MUST provide an option to store platform logs in non-volatile memory in order to preserve log entries across system failures, administrative, or manual reboot or reloads.

A DPoE System is expected to have many debug commands allowing the operator, for example, to enable a debug for an individual routing protocol or a debug for DHCP proxy. A DPoE System might have a number of separate debug commands accessible from CLI. The DPoE System MUST be configurable to enable all such debug options with a single CLI command such that all debug messages are logged into the "local log. " The DPoE System MUST be configurable to enable all debug options with a single CLI command such that all debug messages are logged into the "local log. "

The DPoE System SHOULD be configurable to set thresholds or threshold limits on performance management statistics to create local log, SNMP trap, and syslog events for all statistics.

The DPoE System MUST be configurable to set the size of the local log file. When the DPoE System's log file reaches the max size, the DPoE System SHOULD keep the only the latest logs, removing older logs in a first-in first-out manner.

## 6.8 Syslog Configuration

The DPoE System MUST support syslog with support for facilities local0 through local7 (facilities 16 through 23). The DPoE System SHOULD offer a method (in the configuration file, at the CLI, and/or with XML) to map specific alarm, fault, error, and informational notifications to each facility (local0 through local7), which is customizable by the operator.

The DPoE System MUST support logging to at least two (2) syslog servers. The DPoE System SHOULD be configurable to filter the syslog events for each syslog server by at least syslog facility.

The DPoE System MUST be configurable to individually block or permit each possible log message from being logged to syslog for all syslog servers.

The DPoE System MAY be configurable to individually block or permit each possible log message from being logged to syslog independently for each individual syslog server.

## 6.9 Network Element Addressing

### 6.9.1 Loopback IP Address

The DPoE System MUST support the configuration and operation of at least one (1) loopback interface. The DPoE System MUST support the configuration and operation of at least one (1) IPv4 host address and one IPv6 host address per loopback interface. Thus the loopback interface might be configured single-stack IPv4 or IPv6 or dual



stack with IPv4 and IPv6 configured. The DPoE System SHOULD support the configuration and operation of at least four (4) loopback interfaces Loopback IP addresses are configured as host addresses and have an all 1's mask as shown in the example below.

Example loopback address configuration:

```
! Loopback for SNMP
interface loopback0
description SNMP address
ipv4 address 10.1.1.1 255.255.255.255
ipv6 address 2001:db8:ff2e:f154::1/128
!
! Loopback for Routing
interface loopback1
description D interface forwarding
ipv4 address 1.1.1.1 255.255.255.255
ipv6 address 2001:db8:ff2e:f154::beef/128
```

### 6.9.2 I-BEB

The DPoE System is required to act as an I-BEB as specified in [DPoE-MULPIv2.0] and [DPoE-MEFv2.0]. The DPoE System MUST provide the capability to configure a single I-BEB address for the DPoE System. The DPoE System MAY provide the capability to configure an I-BEB address per line-card in the DPoE System. The DPoE System MUST provide the capability to configure the I-BEB from the CLI and in the configuration file. The DPoE System MAY provide the capability to configure the I-BEB with XML.

Example format of a CLI or configuration file command:

```
ibeb <hhhh>.<hhhh>.<hhhh>
```

Where <hhhh>.<hhhh>.<hhhh> is the assigned MAC address.

Here is an example with a MAC address:

```
ibeb 0000.FF3C.ABCD
```

The I-BEB address on the DPoE System is the B-SA that D-ONUs using [802.1Q] will use when encapsulating ingress traffic at a D-ONU S interface. The I-BEB address on the DPoE System is the B-DA of ingress traffic at the MN interface that is coming from other D-ONUs (through a DPoE System) that have used [802.1Q] encapsulation and configured the B-DA via the DHCP relay process described in [DPoE-MULPIv2.0].

A DPoE System uses a single I-BEB address whether there is one or more than one MN interface. If an operator uses more than one MN interface, then the same I component Backbone Edge Bridge (I-BEB) could be reachable across more than one interface.

### 6.9.3 IPv4 Addressing

The DPoE System MUST support IPv4 network and netmask entry at the CLI and in configurations using either of the following two formats shown by example:

Universal Address	1.1.1.0	255.255.255.0
VLSM Short-Form	1.1.1.0/24	

### 6.9.4 IPv6 Addressing

The DPoE System MUST support IPv6 address text representation at the CLI and in configurations as defined in A Recommendation for IPv6 Address Text Representation [RFC 5952]. The DPoE System MUST be able to parse IPv6 addresses correctly in any of the below formats when configured via any configuration method available.

EXAMPLE 1: 2001:db8:0:0:1:0:0:1/64

EXAMPLE 2: 2001:0db8:0:0:1:0:0:1/64

EXAMPLE 3: 2001:db8::1:0:0:1/64

EXAMPLE 4: 2001:db8::0:1:0:0:1/64

EXAMPLE 5: 2001:0db8::1:0:0:1/64

EXAMPLE 6: 2001:db8:0:0:1::1/64

EXAMPLE 7: 2001:db8:0000:0:1::1/64

EXAMPLE 8: 2001:DB8:0:0:1::1/64

The DPoE System **MUST** display IPv6 addresses in the short IPv6 form with the numerical network mask value as shown below:

EXAMPLE 9: 2001:db8::1:0:0:1/64

## 6.10 Management Addresses

- The DPoE System **SHOULD** provide the capability to designate the following IP service proxies, Application Layer Gateways (ALG), and IP signaling and forwarding to each loopback with the CLI, in the configuration file, and via XML (if XML is supported):
  - IP forwarding (IP routing)
  - SSH2/SFTP
  - FTP
  - TFTP
  - SCP (RCP + SSH2)
  - HTTP
  - NTP
  - Telnet
  - DNS (CLIENT)
  - SNMPv2/SNMPv3

For example, an operator may choose to allow SSH2 access only to a particular (loopback) IP address on the DPoE System to enhance IPNE security. In another example, an operator may choose to allow FTP on a particular (loopback) IP address in order to limit access to file transfers.

The DPoE System **MUST** support IPv4 IP Precedence marking of all IPv4 traffic on the D interface by configuration based on these parameters in any combination:

- Source IPv4 address
  - Including Management (Loopback) IPv4 Address
  - D interface IP addresses
- Transport Layer Protocol
  - Source Transport Layer Protocol Port
    - Transport Layer Protocol port for the corresponding IP service, proxy, ALG, or daemon

The DPoE System **MUST** support IPv4 Diff-Serv Code Point (DSCP) [RFC 2474] marking of all IP traffic on the D interface by configuration based on these parameters in any combination:

- Source IP address
  - Including Management (Loopback) IPv4 Address
  - D interface IP addresses
- Transport Layer Protocol
- Source Transport Layer Protocol Port
  - Transport Layer Protocol port for the corresponding IP service, proxy, ALG, or daemon

The DPoE System **SHOULD** support IPv6 Traffic Class (TC) marking of all IPv6 traffic on the D interface by configuration based on these parameters in any combination:

- Source IPv6 address
  - Including Management (Loopback) IPv6 Address
  - D interface IPv6 addresses
- Transport Layer Protocol
- Source Transport Layer Protocol Port
  - Transport Layer Protocol port for the corresponding IP service, proxy, ALG, or daemon

The DPoE System **MUST** support IPv4 ACLs to limit or block access to management based on:

- Source IPv4 address
- Source Transport Layer Protocol Port
- Transport Layer Protocol
- Destination IPv4 Address
- Destination Transport Layer Protocol Port

The DPoE System **MUST** support IPv6 ACLs to limit or block access to management based on:

- Source IPv6 address
- Source Transport Layer Protocol Port
- Transport Layer Protocol
- Destination IPv6 Address
- Destination Transport Layer Protocol Port

## 6.11 Documentation Requirements

The DPoE System documentation should describe at least the following:

- Physical Dimensions
  - Length, width, depth, and weight of each chassis or shelf
  - Length, width, depth, and weight of all sub-systems, cards, modules, etc.
  - The physical dimensions should indicate clearance required for connectors including network interfaces, power, and safety (grounding) connectors

- The physical dimensions should clearly indicate whether the dimensions for weight, size, and clearance include pluggable optical modules or not in the product documentation.
- The physical dimensions should be documented in both text and 2D (two-dimensional) drawings
- The physical dimensions should include an estimated gross weight calculation for a fully-loaded system including the heaviest possible (including optional) line cards and modules and should clearly state the assumptions of such a system configuration used to provide such an estimate.
- Redundant power configuration
- Power supply load sharing
- Power supply source voltage, frequency, and current draw for AC and DC. Power factor (for AC supplies).
- Module or card insertion, removal, and hot-swap procedures
- Failover process for redundant modules or cards
- Release notes (bug lists, resolved, and un-resolved)
- User reference
- Installation (Software/Image)
- Cabling
- Rack mount
- Interface reference
- Troubleshooting
- Technical support contact information
- Software upgrade (Method of Operation)
- Environmental requirements for safe and warranted operation include at least:
  - Operating temperature range
  - Operating humidity range
  - Operating altitude
  - Air quality requirements (if applicable)
  - Storage temperature range
  - Storage humidity range
- Regulatory compliance as required but at least including:
  - FCC Class and other markings for lasers
  - FCC markings for RF emissions if applicable
    - Underwriters Laboratory Listing (ULL)

The DPoE System documentation is to be available online (but may require secure access). The DPoE System documentation is to be available for download via FTP or SFTP (but may require secure access). The DPoE System documentation should be available in Portable Document Format (PDF). The DPoE System documentation is to be available in a packaged document format that can be viewed online, on a computer, or printed.

## 6.12 IP Services

The DPoE System **MUST** support the following IP service daemons, helpers, proxies, or Application Layer Gateways:

- SSH2/SFTP
- FTP
- SCP (RCP + SSH2)
- TFTP
- HTTP
- NTP
- Telnet
- DNS Proxy (Server)
- SNMPv2
- BOOTP Relay
- DHCP Relay

These are so called "small servers" and are distinct from the client requirements in Section 6.15. Each of these provides a service where the DPoE System acts like a server (or host) providing that service to other clients. Those clients may be other hosts, other DPoE Systems, CMTS, routers, switches, or any other host or network element.

The DPoE System **MAY** support the following IP service daemons, helpers, or ALGs:

- PCMM
- DSG Proxy

The DPoE System **MUST** support UTC Time Zone setting for NTP. The DPoE System **SHOULD** support the ability to configure the NTP server via IPv4 address, IPv6 address, or FQDN.

The DPoE System **MUST** support at least four (4) helper IP addresses for each DHCP, BOOTP, DNS, and other helpers.

The DPoE System **MUST** operate as a DNS proxy, forwarding all DNS queries to DNS servers configured. The DPoE System **MUST** support DNS operating over IPv6. The DPoE System **MUST** perform AAAA queries for IPv6 address resolution. The DPoE System **MUST** have a configurable parameter to query for a IPv4-only address resolution (A), IPv6-only address resolution (AAAA) or dual-stack resolution querying for both A and AAAA records. The DPoE System **MUST** support A queries over both IPv4 and IPv6. The DPoE System **MUST** support AAAA queries over both IPv4 and IPv6.

### 6.12.1 Other Daemons

The DPoE System **MUST** support the capability to enable and disable each and every IP service or protocol daemon (as listed above) at the CLI or in the system configuration file

### 6.12.2 DHCP Relay Configuration

The DPoE System **MUST** implement a DHCP relay (helper) to implement DHCP as specified in [DPoE-MULPIv2.0]. The DPoE System **MUST** support the ability to configure the BOOTP and DHCP Relay (helpers or proxies) via IPv4 address or IPv6 address. The DPoE System **SHOULD** support the ability to configure the BOOTP and DHCP Relay (helpers or proxies) via FQDN.

The DPoE System **MUST** use the I-BEB configured from Section 6.9.2 to populate the DHCP relay-agent for the system capabilities option specified in [eDOCSIS], for the DPoE PBB sub-option (code 4) as specified in [CL-SP-CANN-DHCP-Reg], "DPoE System DHCPv4 PBB service option" Requirements.

The vCMs existing on the DPoE System will periodically renew their DHCP leases. The DPoE System MUST provide a method of limiting the rate of DHCP lease renewals by providing a configurable limit of the number of lease renewals permitted on the DPoE System, for each individual helper (relay) for a moving window for which the period (in seconds) is configured.

### 6.12.2.1 DHCP DAC Relay Requirements

The DPoE System MUST provide the ability to enable or disable the insertion of the CL\_BOOTFILE\_URI into DHCP messages as described in [DPoE-DEMARCv2.0].

The DPoE System MUST provide the ability to configure the CL\_BOOTFILE\_URI within the DPoE System configuration. An example of the DAC file transfer object is displayed below. This DAC file transfer object would be associated with a serving group interface.

Dac file-transfer

```
Address-family [ipv4-only|ipv6-only|dual-stack]
Method [SFTP|HTTPS]
Server [ipv4|ipv6] x.x.x.x [or] xxxx::xxxx [or] FQDN
```

The DAC file-transfer address-family object is used to indicate whether the DPoE System should utilize DNS AAAA record lookups (for IPv6), A record lookups (for IPv4), or both.

If the DAC file transfer server is configured for an FQDN, the DPoE System MUST perform DNS resolution prior to insertion into the CL\_BOOTFILE\_URI option.

The DPoE System SHOULD cache the DNS response for the file-transfer server up to the advertised TTL.

The DPoE System MUST never add more than a single instance of the CL\_BOOTFILE\_URI option to a single DHCPv4 offer or DHCPv6 reply.

## 6.13 Physical Product Requirements

The following requirements are for the physical aspects of the DPoE System.

### 6.13.1 General Requirements

The DPoE System MUST have hot-swappable line cards for all line cards used within a single chassis.

Centralized components or sub-systems within the DPoE System (such as power supplies, fabrics, switches, and processor cards) SHOULD be redundant and field replaceable.

DPoE System SHOULD implement redundant options to distribute, move, or fail-over all services and functions in one (1) second or less. Any option that takes longer than one (1) second should not be identified as redundant.

DPoE System functions that are redundant SHOULD offer a method to manually force a fail-over or otherwise switch service for any redundant capability.

The DPoE System SHOULD be Network Equipment Building Standard (NEBS) Level 3 Compliant.

### 6.13.2 Power Requirements

The DPoE System SHOULD have redundant power supplies.

The DPoE System SHOULD draw power (load share) across all power supplies rather than operating with a primary and backup or switching implementation. Load sharing is helpful to distribute and manage overall power system reliability in facilities.

### 6.13.3 Rack Mount Requirements

The DPoE System MUST be rack mountable in an EIA/ECA-310 rack or cabinet.

#### 6.13.4 Cabling

The DPoE System MAY have fiber and twisted-pair Ethernet cable management integrated. The DPoE System MUST NOT require external lashing for interfaces or power connectors.

The DPoE System SHOULD support SC/UPC and LC/UPC connectors for any integrated (not modular) interfaces for MN or D.

#### 6.13.5 Grounding

The DPoE System MUST have a terminal connector for electrical safety grounding. The DPoE System MUST have a wire terminal for electrical (safety) ground bonding.

#### 6.13.6 Environmental Requirements

The DPoE System is expected to be capable of operating in the temperature range of 0 to 40 degrees Celsius continuously. The DPoE System is expected to be capable of operating in temperatures up to 50 degrees Celsius for up to 24 hours.

The DPoE System is expected to be capable of operating from 5% to 95% humidity.

The DPoE System is expected to be capable of operating at altitudes from -200 feet (below sea level) to 10,000 feet (above sea level).

### 6.14 Message of the Day

The DPoE System MUST provide a method to configure a Message Of The Day (MOTD) via the configuration file. The DPoE System MUST display the MOTD each and every time a secure connection (login) to the CLI is authenticated regardless of the protocol used for the connection. The DPoE System SHOULD provide a minimum of 2048 characters in multiple lines for the MOTD.

### 6.15 Broadband Intercept

The DPoE System SHOULD support broadband intercept using one or more of the following methods:

- [IPFIX]
- Port Mirroring
- ACL Based IP Port Mirroring
- [CBI2.0]

### 6.16 Diagnostics

Diagnostic functions assist the operator in the operations, administration, and maintenance of the DPoE System. Diagnostic functions are used both interactively and scripted.

#### 6.16.1 System Diagnostics

The DPoE System MUST provide a CLI command that dumps all necessary system information (such as configuration, logs, settings, states, etc.) to the CLI for debugging, troubleshooting, and reporting.

#### 6.16.2 IP Statistics

The DPoE System MUST track and support the following statistics per direction for the D and TU interfaces:

- Bits Per Second (BPS) (per interface)
- Packets Per Second (PPS) (per interface)
- IP Subnets in Use (count)

- ACL Filters in use (count and list of ACL numbers)

The DPoE System **MUST** provide a method to display and reset these statistics from a CLI. The DPoE System **MAY** provide a method to obtain and reset these statistics via an XML (API).

### 6.16.3 Ethernet Diagnostics<sup>8</sup>

The DPoE System **SHOULD** support [802.1ag] Connectivity Fault Management (CFM) diagnostics for the MN interfaces. The DPoE System **MUST** support [802.3], Clause 57 Link diagnostics on D-ONUs by providing a method to operate D-ONU S interface loopback as specified in [DPoE-OAMv2.0].

## 6.17 Certificate Entry

This section intentionally left blank.

## 6.18 Power Saving<sup>9</sup>

If the DPoE System supports the power saving mechanism, the DPoE System **MUST** provide a CLI mechanism to control the following aspects of the power saving mechanism:

- if the power saving mechanism is supported on the given TU interface, enable / disable the power saving mechanism on the selected TU interface. The example of the respective command is shown below:
- CLI# power-save cable modem interface <tu> enable / disable
- if the power saving mechanism is enabled on the given TU interface and the power saving mechanism is supported for the given ONU (vCM), enable / disable the power saving mechanism for the selected ONU (vCM) instance,
- CLI# power-save cable modem <mac> enable / disable
- if the power saving mechanism is enabled for the given ONU (vCM) is enabled, configure the parameters of the power saving mechanism, including the maximum duration of the sleep cycle, target sleep mode for the ONU, etc.
- CLI# power-save cable modem <mac> cycle-length <ms>
- CLI# power-save cable modem <mac> sleep-mode <type>

---

<sup>8</sup> Revised per IPNEv2.0-N-14.0170-1 on 7/11/14 by JB.

<sup>9</sup> Revised per IPNEv2.0-N-14.0197-1 on 11/18/14 by JB.



## 7 EPON-SPECIFIC IPNE REQUIREMENTS

In addition to the common requirements, there are some additional DPoE specific requirements for the DPoE System element management, included in the following subsections.

### 7.1 EPON Performance<sup>10</sup>

A DPoE System is expected to be capable of forwarding at least 950 Mbps downstream and 850 Mbps upstream on a 1G-EPON TU with sixty-four (64) D-ONUs registered.

A DPoE System is expected to be capable of forwarding at least 1800 Mbps downstream and 900 Mbps upstream on a 2G-EPON TU with sixty-four (64) D-ONUs registered.

A DPoE System is expected to be capable of forwarding at least 8.7 Gbps downstream and 8.3 Gbps upstream on a 10/10G-EPON TU with sixty-four (64) D-ONUs registered.

### 7.2 EPON Configuration

The DPoE System SHOULD provide a CLI command for any DPoE System capabilities to enable and disable TU interfaces or control other EPON settings that the DPoE System may offer.

The DPoE System MUST provide a CLI command to configure the default Nominal Polling Interval for use when a Nominal Polling Interval is not specified within the CM configuration file.

#### 7.2.1 10G-EPON and 1G-EPON Compatibility Settings<sup>11</sup>

The DPoE System MUST provide CLI commands to indicate whether a TU interface is operating as 10/10G-EPON, 10/1G-EPON, 2/1G-EPON, or 1G-EPON.

#### 7.2.2 ONU Rate Mode Capability

A D-ONU that supports 2G-EPON SHOULD support two rate modes:

1G Mode: downstream 1Gbps, upstream 1Gbps.

2G Mode: downstream 2Gbps, upstream 1Gbps.

A D-ONU that supports 2G-EPON SHOULD report its rate mode capability to the 2G-OLT via the extended OAM message defined in [DPoE-OAMv2.0].

For D-ONUs that do not support 2G-EPON, the rate mode reporting function is optional.

The D-ONU reports its rate mode capability via the extended attributes of ONU Capabilities defined in [DPoE-OAMv2.0]

#### 7.2.3 2G-EPON Compatibility Requirements

A DPoE System that supports 2G-EPON SHOULD be backward compatible to a DPoE System that only supports 1G-EPON. The detailed compatibility requirements are as below:

A 2G-OLT in a DPoE System SHOULD support manual rate mode configuration via the network management system (i.e., manually configuring OLT to operate in 2G Mode or 1G Mode).

A D-ONU that supports 2G-EPON MUST select its operation mode (either 2G Mode or 1G Mode) according to OLT downstream operation rate.

The detailed compatible scenarios are shown in Figure 5.

<sup>10</sup> Revised per IPNEv2.0-N-13.0104-1 on 10/4/13 and IPNEv2.0-N-14.0186-1 on 7/11/14 by JB.

<sup>11</sup> Revised per IPNEv2.0-N-14.0186-1 on 7/11/14 by JB.

1. A D-ONU that supports 1G Mode can join a DPoE System operating at 1G, and operates as a 1G-EPON ONU on the same single OLT PON, not requiring any changes for existing 1G-EPON OLTs and 1G-EPON ONUs. During the power on and registration process, D-ONUs that support 2G-EPON SHOULD detect the 1G downstream signal and automatically implement initialization to work in 1G Mode. See scenarios C and E.
2. If an OLT that supports 2G-EPON is manually configured in a DPoE System to operate in 1G Mode, a D-ONU that only supports 1G-EPON can access this PON interface without any changes to the existing D-ONUs. A D-ONU that supports 2G-EPON SHOULD detect the 1G downstream signal and automatically implement initialization to operate in 1G Mode. See scenarios B and D.
3. If an OLT that supports 2G-EPON is manually configured in a DPoE System to operate in 2G Mode, a D-ONU that only supports 1G-EPON cannot access this PON interface. A D-ONU that supports 2G-EPON SHOULD detect the 2G downstream signal and automatically implement initialization to work in 2G Mode. See scenario F.

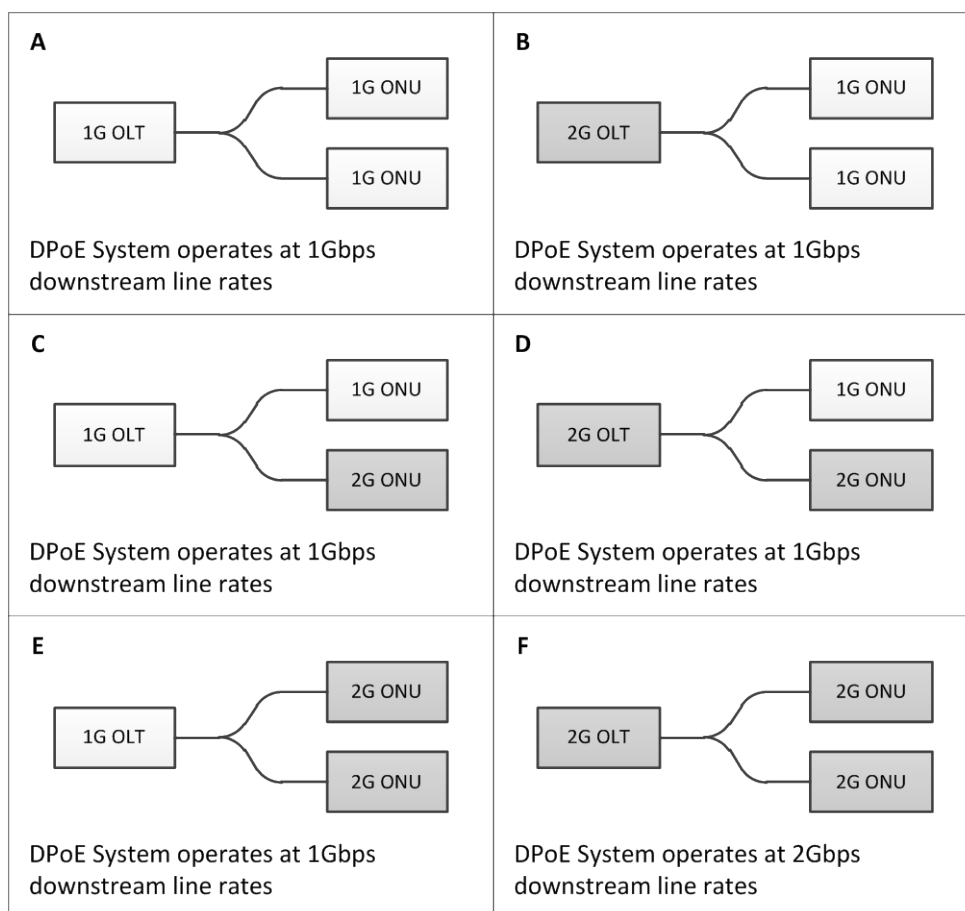

**Figure 5 - 2G-EPON System Backward Compatibility with 1G-EPON System**

## 7.2.4 EPON OAM Configuration

This object controls the rate at which OAM messages are sent on an EPON (TU) interface per LLID.

Attribute Name	Type	Value Range	Units	Default Value
Minimum OAM Rate	Int	0 .. 255	PDU/s/sec	1
Maximum OAM Rate Mode	ENUM	Disabled Enabled	NA	Disabled
Maximum OAM Rate	Int	1 .. 65535	PDU/s/sec	30
OAM Response Timeout	Int	1 .. 255	Secs	1

The DPoE System SHOULD provide a command to view the operating OAM PDU rate.

The DPoE System MUST provide a CLI command to globally set the max OAM PDU rate.

## 7.2.5 EPON (TU) Interface Objects

The attributes listed in the sections that follow are defined per EPON (TU) Interface on the DPoE System

### 7.2.5.1 EPON (TU) Interface

The DPoE System MUST support configuration of the following attribute for each EPON and 10G-EPON TU interface:

Attribute Name	Type	Value Range	Units	Default Value
Admin State	ENUM	up down testing See [RFC 2863]	NA	up

The DPoE System MUST support configuration of the following attributes for each EPON TU interface:

Attribute Name	Type	Value Range	Units	Default Value
Upstream FEC Mode	ENUM	Disabled Enabled Per ONU <sup>1</sup>	NA	Enabled
Downstream FEC Mode	ENUM	Disabled Enabled Per ONU <sup>1</sup>	NA	Enabled
Note 1 'Per ONU' indicates that FEC will be enabled or disabled based on how the ONU is provisioned.				

The DPoE System SHOULD support configuration of the following attributes for each 10G-EPON TU interface:

Attribute Name	Type	Value Range	Units	Default Value
Upstream FEC Mode	ENUM	Disabled Enabled Per ONU <sup>1</sup>	NA	Enabled
Downstream FEC Mode	ENUM	Disabled Enabled Per ONU <sup>1</sup>	NA	Enabled
Note 1 'Per ONU' indicates that FEC will be enabled or disabled based on how the ONU is provisioned.				

The DPoE System MUST provide a CLI command to globally enable or disable Forward Error Correction (FEC) for EPON TU interface. The DPoE System SHOULD provide a CLI command to globally enable or disable Forward Error Correction (FEC) for 10G-EPON TU interface. The DPoE System MUST provide a CLI command to enable

or disable FEC per EPON TU. The DPoE System SHOULD provide a CLI command to enable or disable FEC per 10G-EPON TU. The DPoE System MUST prefer the per-TU configuration setting over the global setting if the two are in conflict. If there are multiple TULs that operate over a single TU the per-TU FEC configuration MUST apply to all TULs operating over that TU.

The DPoE System MUST support configuration of the following attributes for each 2G-EPON interface:

Attribute Name	Type	Value Range	Units	Default Value
Speed	ENUM	1 Gbps 2 Gbps DS/1 Gbps US	NA	1 Gbps

## 7.2.6 EPON TUL Interface Objects

The attributes listed in the sections that follow are defined per EPON TUL Interface on the DPoE System.

### 7.2.6.1 EPON TUL Interface

The DPoE System MUST support configuration of the following attributes for each EPON TUL interface:

Attribute Name	Type	Value Range	Units	Default Value
Number of LLIDs Supported	Int (RO)	1 .. 32767	NA	NA

### 7.2.6.2 Loop Timing

The DPoE System MUST support the following attributes related to Loop Timing for EPON TUL interfaces:

Attribute Name	Type	Value Range	Units	Default Value
Minimum Propagation Delay	Int	0 .. 65535	16 ns TQ	0
Maximum Propagation Delay	Int	0 .. 65535	16 ns TQ	6250
ONU Delay	Int	3125 .. 65535	16 ns TQ	3125

### 7.2.6.3 MPCP Configuration

The DPoE System MUST support the following attributes related to configuring the use of MPCP on the EPON for EPON TUL interfaces:

Attribute Name	Type	Value Range	Units	Default Value
Discovery Period	Int	10 .. 65530	msecs	1000
Grant Size in Discovery Gate	Int	42 .. 65535	16 ns TQ	8160
Deregistration Timeout	Int	0 .. $2^{32} - 1$	msecs	1000

## 7.2.7 Fault Management<sup>12</sup>

The DPoE System SHOULD support a CLI command to enable or disable the D-ONU Remote Loopback mode per D-ONU as specified by [802.3], Clause 57.

## 7.2.8 LLDP Configuration<sup>13</sup>

The DPoE System MUST have a configurable TTL for LLDP messages originated from D-ONUs. The DPoE System SHOULD set the default TTL for LLDP messages to be 2 seconds.

<sup>12</sup> Revised per IPNEv2.0-N-14.0141-1 on 5/20/14 by JB.

<sup>13</sup> Revised per IPNEv2.0-N-14.0141-1 on 5/20/14 by JB.

### 7.3 Virtual Cable Modem Display and Configuration<sup>14</sup>

The DPoE System MUST provide a CLI 'show' command to show the registration status, authentication status, operating interfaces, and the data rate (10/10G-EPON, 10/1G-EPON, 2/1G-EPON, or 1G-EPON) for a D-ONU based on a provided D-ONU MAC address.

The DPoE System MUST support a 'show' command that shows interfaces configured on each D-ONU.

The DPoE System MUST support a 'show' command that shows received optical power for each D-ONU.

The DPoE System MUST support a 'show' command that shows the S-VLAN ID, if applicable, for each active S1 interface on each D-ONU.

Example Show vCM:

```

CLI# show vcm
Interface SID      State  Rec      Interface  CPE or eSAFE address  SVID/  MAC address
                Power
tu0      10      <str>  0.25     online CMCI  10.1.1.25             0000.0000.0001
                11      M*      0000.FFFF.0001
                12      LCI     10.30.2.1
tu0      13      <str>  0.28     online M*   0000.FFFF.0002       102    0000.0000.0002
tu0      14      <str>  0.30     online M*   0000.FFFF.0003       103    0000.0000.0003

```

In this example, <str> is a coded string to indicate an EPON or DPoE registration state.

Example Show d-onu <MAC>:

```

CLI# show d-onu 0000.0000.0001
tu0      10      <str>  0.25     online CMCI  10.1.1.25             1/1    0000.0000.0001
                11      MU      0000.FFFF.0001       101/*
                12      LCI     10.30.2.1             1/2

```

The DPoE System MUST provide a CLI command that shows all virtual cable-modems.

The DPoE System MUST provide a CLI command to cause the dynamic configuration update in the same manner as if the dpoeVcmDynCfgNow MIB object were set via SNMP.

The DPoE System MUST provide a CLI command to display the current status of the power saving mechanism for all TU interfaces on the DPoE System. Example of "show cable interface power-save" command is shown below.

```

CLI#show cable interface power-save
interface      power saving status
tu0            enabled
tu1            disabled
tu2            not supported

```

The DPoE System MUST provide a CLI command to display the current status of the power saving mechanism for selected vCMs on the DPoE System, including the sleep period and the sleep mode. Example of "show cable modem power-save" command is shown below. This command should support display per selected vCM instance and per selected TU interface.

```

CLI# show cable modem power-save
MAC address   IP address   power saving status  sleep mode   sleep period
0025.dc53.4ff0 97.76.238.89 enabled          rx           10ms
0025.dc53.4ff4 97.76.238.19 enabled          rx/tx        20ms
0025.dc53.4ff1 97.76.238.91 disabled          n/a          n/a
0025.dc53.4ff2 97.76.238.93 not supported      n/a          n/a

```

<sup>14</sup> Revised per IPNEv2.0-N-14.0141-1 on 5/20/14 and IPNEv2.0-N-14.0186-1 on 7/11/14 by JB. Revised per IPNEv2.0-N-14.0197-1 on 11/18/14 by JB.

## 7.4 EPON Diagnostics

The DPoE System **MUST** support basic EPON debug capabilities such as EPON ONU registration logging and optical receive power as defined in [SFF-8472] and [SFF-8077i]. The DPoE System **SHOULD** support rolling counters for the received EPON OAM PDUs. The DPoE System **SHOULD** support displaying the rate at which EPON OAM PDUs are received per second across a 30 second window. Such EPON debugging should be operator configurable to be enabled and disabled on per TU interface or per ONU MAC address, or for the entire DPoE System.

## 7.5 Multi-Source Agreement Transceivers

The DPoE System TU interface **SHOULD** support one of the Small Form Factor Committee Multi-Source Agreement (MSA) standards for pluggable transceivers such as SFP, SFP+, or XFP. Modular transceiver interfaces provide operators with the flexibility to select, install, or change the proper optical transceiver for current needs on the TU interface.

## 7.6 VCM Logging

The DPoE System **MUST** support logging (local log and syslog) for severe error ONU logging as follows:

- Report D-ONUs that register, de-register, and re-register more than N times in T time, where N and T are operator configurable.
- Report the last known optical power and signal parameters available for a failed D-ONU registration.

## 8 DPOE PROTOCOL SPECIFIC SUPPORT

### 8.1 MULPI Parameters

#### 8.1.1 Bundling

Virtual bundles are a logical construct used in DOCSIS for a set of configurations that are applied to one or more cable interfaces. While widely used in DOCSIS, there is no standard for this practice in DOCSIS.

Bundling is the mechanism by which multiple TU interfaces can be associated to one (or more) IP serving groups. Alternatively, a DPoE System could be configured to have some set of TULs associated with one bundle and some other non-overlapping set of TULs associated with another bundle.

Below is an example of the configuration to instantiate a bundle on a DPoE System:

```
interface bundle 1
Description TU0-1
!
interface tul0
bundle 1

interface tul1
bundle 1
!
interface bundle 2
Description TU2-3
interface tul2
bundle 2
!
interface tul3
bundle 2
```

A DPoE System **MUST** support the configuration of all TULs on the DPoE System to the same bundle.

A DPoE System **MUST** support the configuration of the smaller of either at least 4 TULs or the total number of TULs on the DPoE System to a single bundle.

A DPoE System **SHOULD** support at least 4 distinct bundles.

#### 8.1.2 IP Serving Groups<sup>15</sup>

IP Serving Group (IP-SG) configurations are largely an organizational function that allows an operator to group a set of similar service flows together (representing similar services). IP(HSD) IP-SGs are used to forward traffic to a common IP interface on the router within the DPoE System. L2(HSD) IP-SGs are used to forward traffic to an external interface. Such functionality is achieved today in shipping DOCSIS CMTS products using vendor-specific mechanisms. However, detailed requirements for such mechanisms are not part of DOCSIS specifications This section describes the configuration capabilities required for the IP-SG.

A sample configuration for a serving group configuration is below:

```
interface tul0
bundle 1
!
interface tul3
bundle 1
!
interface bundle 1.1
Description "Example bundle configuration for default IP-HSD"
default
    docsis attribute-mask 80000001
    [ip configuration parameters]
!
interface bundle 1.2
```

<sup>15</sup> Revised per IPNEv2.0-N-14.0141-1 on 5/20/14 and per IPNEv2.0-N-15.0207-1 on 4/13/15 by JB.

```

Description "Example bundle configuration for default MTA"
  docsis attribute-mask 80000002
  [ip configuration parameters]
!
interface bundle 1.3
Description "Example bundle configuration for DEMARC Auto Config (DAC)"
s-vlan 1003
  docsis attribute-mask 80000004
  multipoint enabled
  bundle-type dac

  [ip configuration parameters]

```

The DPoE System MUST provide CLI configuration command to configure a serving group as shown above. The serving groups 1.1 and 1.2 define IPHSD services whereas the serving group 1.3 defines an L2HSD service.

Also note in the example above the definition of the "docsis attribute-mask" object. In [MULPIv3.0] this object is the SF Required Attribute Mask (TLV24/25.31.) This object might be present in the CM configuration file or it could be referenced via a Service Class object in the CM configuration file. The attribute mask in an SF encoding is used to associate an SF with a particular IP-SG. An instance of an L2HSD service is associated with a "docsis attribute-mask" object either directly (part of the interface bundle definition) or indirectly, through the service class definition.

When an SF does not contain an SF Required Attribute Mask as part of its provisioning, the SF is considered to be part of the IP-SG with the "default" keyword in the configuration, as shown above for "bundle 1.1".

When an S-VID is configured as part of an IP serving group for IP(HSD), the DPoE System OLT MUST add the S-VID, along with the default S-TPID value of 0x88a8, with S-PCP set to 0x0 and S-DEI set to 0x0 to the frame before forwarding the frame to the DPoE System router.

The DPoE System MUST use the configured SF Required Attribute Mask (TLV24/25.31) to associate provisioned IP(HSD) service flows with serving group.

Finally, in the example above note the definition of the "bundle type" object. This object in the configuration example is the configuration of the serving group to associate dynamically configured DAC service-flows to the DAC bundle interface or sub-interface.

The DPoE System MUST support an interface bundle that is configured as the IP interface for all dynamically created DAC SFs. The dynamically created DAC SFs would use the S-VID pool associated with the interface bundle to dynamically generate the S-VID and C-VID used for purposes of encapsulating Ethernet frames from the DEMARC management entity to the router within the DPoE System. The example above shows the bundle-type DAC object as the configuration object to identify the interface bundle as the DAC IP interface.

### 8.1.3 IP(HSD) and L2HSD Services

Users may optionally configure IP(HSD) and L2HSD services. IP(HSD) services provide routing functionalities within the DPoE System whereas L2HSD services are L2 bridges forwarding traffic to an external interface. The configuration of both services are similar with the following key differences:

- The DPoE System MUST NOT include an S-VID definition in the Serving Group definition for an IP-HSD service. If such an S-VID definition exists, the DPoE System MUST instantiate an L2HSD service.
- L2HSD Serving groups may include an optional field that allows user-to-user communication when configured. The field format follows.
  - multipoint enabled|disabled
  - If the optional field is 'disabled' or left blank, the DPoE System MUST NOT allow user-to-user communication for the related SG. Conversely, if the optional field is 'enabled', the DPoE System MUST allow user-to-user communication.



It is important to note that L2HSD services are similar to the L2VPN based L2 bridges. The operators can provision such VLAN-based L2 services using either method. However, the S-VIDs used for such services MUST be distinct and unique among the L2HSD and L2VPN services.

#### 8.1.4 VPN S-VID Allocation

When operating in the simplified MPLS provision mode (per [DPoE-ARCHv2.0]), the DPoE System MUST be able to dynamically allocate S-VID(s) from the configured reserved pool of S-VID(s). Such dynamically allocated S-VID(s) are then used to encapsulate traffic in TRAN-trails spanning from the MU interface on the D-ONU to the MN<sub>i</sub> interface on the DPoE System. The DPoE System MUST support the configuration of an S-VID pool for use for VPN allocations. The following is an example of such a configuration:

```
VPN pool s-vlan [VID-Range]
```

This specification is intentionally silent on the configuration context for this CLI configuration object.

## 8.2 MEF Parameters<sup>16</sup>

### 8.2.1 Encapsulation and Tagging

The DPoE System MUST provide 'show' commands to show the type of encapsulation in use for each S interface configured and active on D-ONUs. The DPoE System MUST provide a 'show' command to show all interfaces operating with PBB encapsulation in a summary.

This example would show PBB forwarding active, by port, on TUL number 0:

```
show interface tul0 pbb
```

This example would show PBB forwarding active, by port, all TUL interfaces:

```
show interface pbb
```

The DPoE System MUST provide a 'show' command to show all PB tagging.

This example would show PB forwarding active, by port for all TUL interfaces:

```
show interface pb
```

The DPoE System MUST provide a 'show' command to show all MU and MI interfaces operating with PB tagging in a summary.

This example would show PB forwarding active, by port, on TUL number 0:

```
show interface tul0 pb
```

This example would show PB forwarding active, by port, all TUL interfaces:

```
show interface pb
```

### 8.2.2 TPID Translation

The DPoE System SHOULD provide a 'show' command to show all TPID translation in use on the system or by interface.

This example would show TPID translation by port on TUL number 0:

```
show interface tul0 xtpid
```

This example would show TPID translation by port on all TUL interfaces:

```
show interface xtpid
```

---

<sup>16</sup> Revised per IPNEv2.0-N-14.0141-1 on 5/20/14 by JB.

### 8.2.3 I-BEB

The DPoE System MUST provide a 'show' command to show the I-BEB configured for the DPoE System.

This example would show the I-BEB configured for the DPoE System:

```
show ibeb
```

## 9 COMBINED IP(HSD) AND MEF NNI FORWARDING REQUIREMENTS

Both the D and MN interfaces on a DPoE System share Ethernet interface and forwarding requirements identified in this section.

### 9.1 Ethernet Interface Requirements

The DPoE System MUST be capable of forwarding Ethernet frames on the D and MN interfaces using [802.1D] and [802.1Q] including Untagged, C-Tagged, S-Tagged, I-Tagged, and B-Tagged frames.

#### 9.1.1 Link Aggregation (LAG)

The DPoE System MUST support [802.1ax]Link Aggregation on the D and MN or combined D and MN interfaces for all network-to-network traffic. The DPoE System MUST support LAG for the smaller of either eight (8) ports or the maximum number of D and MN ports on the DPoE System. The latter would, for example, apply to a DPoE System that might have only 7 or less ports.

The DPoE System MUST support [802.1ax]LAG for all Gigabit Ethernet ports or all 10 Gigabit Ethernet ports. The DPoE System MUST NOT support [802.1ax]across both Gigabit Ethernet ports and 10 Gigabit Ethernet ports.

The DPoE System MUST support Link Aggregation Control Protocol (LACP) as defined in[802.1ax]. The DPoE System SHOULD support the configuration of both fast periodic Link Aggregation Control Protocol Data Units (LACPDU) transmissions and slow periodic LACPDU transmissions. The DPoE System MUST (as configured) support forwarding on all LAG members. The DPoE System SHOULD support active-standby forwarding where some number of the links in a LAG bundle are configured to be active forwarding and some links are configured to be in standby.

#### 9.1.2 D and MN Interface Data Rates<sup>17</sup>

A DPoE System with 1G-EPON and/or 2G-EPON only MUST support Gigabit Ethernet ports for the D and MN<sub>e</sub> interfaces.

A DPoE System with 1G-EPON only SHOULD support 10 Gigabit Ethernet ports for the D and MN<sub>e</sub> interfaces.

A DPoE System with 10G-EPON (10/1G-EPON or 10/10G-EPON) MUST support 10Gigabit Ethernet or greater interface speed for the D and MN<sub>e</sub> interfaces.

A DPoE System with 10/1G-EPON or 10G-EPON MAY support 1Gigabit Ethernet ports for the D and MN<sub>e</sub> interfaces.

A DPoE System SHOULD support modular MSA-compliant Ethernet interfaces for the MN<sub>e</sub> and D interfaces.

#### 9.1.3 NNI Link Aggregation

The DPoE System MUST allow the D and MN interfaces to operate over a combined (trunked) Ethernet interface, using [802.1Q] VLAN tags to separate the two sets of logical interfaces.

---

<sup>17</sup> Revised per IPNEv2.0-N-14.0186-1 on 7/11/14 by JB.

### 9.1.3.1 NNI Link Aggregation Egress Tagging

If a DPoE System is configured to combine D and MNe using [802.1Q] that tag MUST be applied as an outer (trunking) tag in addition to existing PB or PBB tags. A DPoE System multiplexing the logical D and MNe interfaces into a single Ethernet interface MUST NOT remove or re-write any existing tags upon egress from MNe or D.

D-ONUs can accept frames that are tagged by the customer. In addition to accepting customer tagged frames, D-ONUs can be configured to add up to two additional PB tags. With the addition of an optional outer tag (described herein) for NNI link aggregation, egress frames may contain up to four (4) [802.1Q] tags.

D-ONUs can accept frames that are tagged by the customer. In addition to accepting customer tagged frames, D-ONUs can be configured to add PBB encapsulation (tagging). With the addition of an optional outer tag (described herein) for NNI link aggregation, egress frames may contain a combination of up to (2) PB Tags and (2) PBB-Tag.

### 9.1.3.2 NNI Link Aggregation Ingress Tagging

A DPoE System MAY be configured to encapsulate D and MN<sub>e</sub> using a defined [802.1Q] (trunking) outer tag.

If a DPoE System is configured to combine D and MNe using [802.1Q] that (trunking) outer tag MUST be removed before passing the frame to the logical D or MN interface.

## 9.2 IP Forwarding Requirements

IP forwarding requirements apply to the D interface, TUL interface, and S1 interfaces as described below. TUL interfaces used for IP(HSD) can also be concurrently used for Metro Ethernet services. When TUL interfaces are configured for IP(HSD) service, the IP forwarding requirements only apply to IP(HSD) services and therefore only to S1 interfaces configured as CMCI or LCI interfaces.

### 9.2.1 IP Interfaces

The DPoE System MUST support Variable Length Subnet Masking (VLSM) on all IP interfaces. The DPoE System MUST support IPv4 subnet masks of any length, including the /31 subnet mask length, on the D interface. The DPoE System MUST Support IPv6 subnet masks of any length on the D and MNi interface including the /127 subnet mask length.

#### 9.2.1.1 Multinet

The DPoE System MUST support at least eight (8) IPv4 and eight (8) IPv6 subnetworks for each IP-SG. The DPoE System MUST support at least four (4) IPv4 subnetworks and four (4) IPv6 subnetworks for each D interface.

#### 9.2.1.2 Access-Lists

The DPoE System MUST support ACLs and EACLs on every IP interface on the DPoE System to limit and control access to any IPv4/IPv6 address and port combination based on source IPv4/IPv6 address, source transport layer protocol port, destination IPv4/IPv6 address, and destination transport layer protocol port for all IPv4/IPv6 addresses configured on the DPoE System including loopback addresses (if configured), interface addresses, vCM addresses and CPE addresses assigned for any active CMCI interfaces.

The DPoE System SHOULD be configurable to apply such ACLs or EACLs to all or only to specific D interfaces. This will allow operators to use different ACLs on different interfaces if desired.

The DPoE System MAY support EACL for traffic on the D interface based on TCP State.

The DPoE System MUST support Layer 2 ACLs on the D and MNe interfaces. The DPoE System MUST support the following parameters for Layer 2 ACLs:

- MAC
  - Source Address
  - Destination Address

- MAC Address Ranges
  - Source Address
  - Destination Address
- [802.1Q]
  - S-VID
  - C-VID
  - I-SID
  - B-VID
  - S-TPID
  - C-TPID
  - I-TPID
  - B-TPID

The DPoE System MUST support logging of ACL matches. The DPoE System MUST support enabling and disabling of logging of ACL matches per ACL. The DPoE System SHOULD support logging per ACL entry. The DPoE System SHOULD support the enabling and disabling of per-ACL Entry logging messages per ACL entry. The DPoE System SHOULD be configurable such that ACL matches be only logged to remote logging server while all other local logging events are still logged locally.

### 9.2.2 IP(HSD) Multicast<sup>18</sup>

IP(HSD) Multicast support between the D-ONU and DPoE System is implemented based on the [DOCSIS] model. The specific interaction between how the [DOCSIS] model interacts with EPON is defined in [DPoE-MULPIv2.0].

The configuration objects for multicast group management are defined in [MULPIv3.0] and, as a result, will not be described here.

The DPoE System MUST have CLI configuration commands for the Group Configuration (GC), Group QoS Configuration (GQC), IP Multicast Profile and IP Multicast Join Authorization Rule objects defined in [MULPIv3.0].

DPoE System MUST support at least two Join Authorization rules per IP Multicast Profile. The DPoE System SHOULD support at least 16 Join Authorization rules per IP Multicast Profile. More detail on the IP Multicast Profile can be found in [MULPIv3.0].

The DPoE System MUST have a configuration object that enables the SG interface to support IGMPv3 and IGMPv2 simultaneously.

The DPoE System MUST have a configuration object that enables the SG interface to support MLDv2 and MLDv1 clients simultaneously.

The DPoE System MUST have a configuration object that globally enables or disables IP multicast forwarding.

The DPoE System MUST have a standard configuration element for the default Group Service Flow (GSF).

In addition to the default GSF, the DPoE System MUST have a "control" GSF utilized for IPv4 and IPv6 control traffic.

The DPoE System MUST set the control GSF IPv4 default classifier to 224.0.0.0/24. The DPoE System MUST set the control GSF IPv6 default classifier to ffx2::/16.

---

<sup>18</sup> Revised per IPNEv2.0-N-14.0141-1 on 5/20/14 by JB.

The DPoE System SHOULD have a configuration object to allow an operator to change the default classifier for the control GSF.

### 9.2.3 SF and MESP QoS Assignment

The DOCSIS Service Class is referenced within the CM configuration file and points to a configured Service Class on the DPoE System, The DOCSIS Service Class may also be referenced from a SG to allocate QoS parameters for service flows that are dynamically created by the DPoE System.

The DOCSIS Service Class is defined in [MULPIv3.0].

The DPoE System MUST support a DOCSIS Service Class, which includes (at a minimum) the following configurable elements:

- Service Class Name
- ToS Overwrite
- SF Required Attribute Mask (TLV24/25.31)
- SF Forbidden Attribute Mask (TLV 24/25.32)
- Priority
- Type: DOCSIS QoS Profile (DQP) | Metro Ethernet Service Profile (MESP)
- DQP values:
  - Service Flow Scheduling Type to include RTPS and Best Effort
  - Upstream Maximum Sustained Traffic Rate
  - Downstream Maximum Sustained Traffic Rate
  - Maximum Traffic Burst
- MESP values:
  - Committed Information Rate
  - Committed Burst Size
  - Excess Information Rate
  - Excess Burst Size

The DPoE System MAY more configuration elements within the service class beyond those enumerated here.

## 9.3 Routing and Forwarding

### 9.3.1 Route Distribution

The DPoE System MUST support IP route redistribution from every active IP routing protocol to every other IP routing protocol.

The DPoE System MUST support IP route redistribution of connected and static routes to every IP routing protocol.

The DPoE System SHOULD support the redistribution of at least 8,000 routes from any IP routing protocol into every other IP routing protocol.

### 9.3.2 Bi-Directional Forwarding Detection

The DPoE System MUST support Bi-Directional Forwarding Detection (BFD) as specified in [RFC 5880], [RFC 5881], and [RFC 5882] on the D interface.

The DPoE System MUST provide configurable timers for BFD.

The DPoE System MUST support timers as low as 50 milliseconds.

The DPoE System SHOULD support timers as low as 15 milliseconds.

The DPoE System MUST support BFD with OSPFv2 as a client.

The DPoE System MUST support BFD with IS-IS as a client.

The DPoE System MUST support BFD with OSPFv3 as a client.

The DPoE System MUST support BFD with static routes as a client.

The DPoE System MUST support BFD with PIM as a client.

The DPoE System MUST support BFD with LDP as a client.

The DPoE System MUST support BFD with iBGP as a client.

### 9.3.3 Equal Cost Multi-Path

The DPoE System MUST support Equal Cost Multi-Path (ECMP) for IP forwarding based on all IP routing protocols and static routes (including default route and default network).

The DPoE System MUST support load balancing across equal paths for IPv4, IPv6, and MPLS flows.

The DPoE System SHOULD support an MPLS label stack up to four labels deep for purposes of ECMP flow-based load balancing.

The DPoE System SHOULD support the use of source and destination IPv4 address, protocol, and source and destination upper layer protocol port as parameters for purposes of ECMP flow-based load balancing.

The DPoE System SHOULD support the use of source and destination IPv6 address, protocol, and source and destination upper layer protocol port as parameters for purposes of ECMP flow-based load balancing.

The DPoE System MUST support the minimum of at least four (4) MAX-PATHS for ECMP.

The DPoE System SHOULD support the minimum of at least sixteen (16) MAX-PATHS for ECMP.

### 9.3.4 Policy Based Routing

Policy based routing is routing decisions based on the information within the IP header other than destination IP address based lookup only.

The DPoE System MUST support policy based routing decisions based on the source IPv4 address.

The DPoE System SHOULD support policy based routing decisions based on the source IPv6 address.

### 9.3.5 Static Routes

The DPoE System MUST support static IPv4 routes configured by the configuration file or at the CLI.

The DPoE System MUST support static IPv6 routes configured by the configuration file or at the CLI.

The DPoE System MUST provide the capability to provide a protocol weight for each and every static route such that operators can make a decision whether the static route is preferred over the same prefix learned by other means.

The DPoE System MUST provide the capability to remove static routes from the active forwarding routes (but keep the configuration file the same) when BFD detects a next-hop failure.

### 9.3.6 Default Route

The DPoE System MUST support the configuration of a static route to which all traffic not otherwise reachable by other routing protocols or static routes should be forwarded by default.

The DPoE System MUST support at least four (4) default routes.

The DPoE System MUST support BFD for default routes just as for static routes.

The DPoE System MUST provide the capability to remove default routes from the active forwarding routes (but keep the configuration file the same) when BFD detects a next-hop failure.

### 9.3.7 Interior Gateway Protocols (IGPs)

The DPoE System MUST support IS-IS [ISO/IEC 10589] for IGP routing.

The DPoE System MUST support OSPFv2 ([RFC 2328] and [RFC 3623]) for IGP routing.

The DPoE System MUST support OSPFv3 [RFC 5340] for IGP routing.

The DPoE System MUST support route redistribution between IGPs.

The DPoE System MUST support route redistribution between IGPs and BGP.

The DPoE System MUST support a route policy language for limiting IP route distribution into the routing protocols.

The DPoE System MUST support a route policy language for configuration of IP route distribution between routing protocols.

The DPoE System MUST support the capability to run IS-IS, OSPFv2 and OSPFv3 on the same DPoE System simultaneously.

The DPoE System MUST provide the capability to remove OSPFv2, OSPFv3, or IS-IS adjacencies from the link state database (but keep the adjacency configured) when BFD detects an adjacency failure.

The DPoE System MUST keep running BFD and upon recovery from the link failure, should re-establish the adjacency and admit the route to the link state database.

The DPoE System SHOULD support IP FRR as defined in Basic Specification for IP Fast Reroute: Loop-Free Alternates [RFC 5286].

The DPoE System SHOULD support IP FRR with Remote LFA.

The DPoE System MUST support LDP IGP Synchronization [RFC 5443].

The DPoE System SHOULD support LDP Session Protection.

The DPoE System MAY support LDP IGP Synchronization for Broadcast Networks [RFC 6138].

#### 9.3.7.1 OSPF

The DPoE System MUST support OSPF "not so stubby" areas [RFC 3101].

The DPoE System MUST support the ability to set tag values per IP subnet in type 7 Link State Advertisements (LSAs).

The DPoE System MUST support point-to-point links without a designated router (DR).

The DPoE System MUST label routes redistributed into OSPF as type 5/7 LSAs.

The DPoE System MUST support Graceful OSPF Restart [RFC 3623].

The DPoE System SHOULD support OSPFv3 Graceful Restart [RFC 5187].

The DPoE System MUST support a configurable OSPF autocost reference bandwidth of between 100 megabits per second and 1 Terabit per second.

The DPoE System MAY support a configurable OSPF autocost reference bandwidth greater than 1 Terabit per second (Tbps).

The DPoE System MAY support Multi-Topology Routing in OSPF [RFC 4915].

The DPoE System MAY support advertising IPv4 prefixes inside of OSPFv3 as defined in Support of Address Families in OSPFv3 [RFC 5838].

The DPoE System MUST support OSPFv2 neighbor MD5 authentication.



The DPoE System SHOULD support the ability to configure LSA pacing for OSPFv2.

The DPoE System SHOULD support the ability to configure LSA pacing for OSPFv3.

The DPoE System SHOULD support the ability to enable prefix prioritization such that the DPoE System would, for instance, prioritize converging all loopback prefixes (IPv4 /32s or IPv6 /128s) before all other prefix lengths.

The DPoE System SHOULD support the ability to configure a delay (hold timer) between the time a link-state change is detected and OSPF runs the SPF algorithm.

The DPoE System SHOULD support the ability to configure a progressive backoff system for that delay with a max-wait value.

### 9.3.7.2 IS-IS

The DPoE System MUST support multiple-topology IS-IS (M-IS-IS) as specified in [RFC 5120].

The DPoE System MUST support MT extensions for LSP in order to support multiple-topology as specified in [RFC 5311].

The DPoE System MUST support Routing IPv6 with IS-IS [RFC 5308].

The DPoE System MUST support a configurable IS-IS autocost reference bandwidth of between 100 megabits per second and 1Tterabit per second.

The DPoE System MAY support a configurable IS-IS autocost reference bandwidth greater than 1 Tbps.

The DPoE System SHOULD support IS-IS BFD-Enabled TLV [RFC 6213] to enable IS-IS to react appropriately to a BFD-detected forwarding plane failure.

The DPoE System SHOULD support the ability to configure LSA pacing for IS-IS.

The DPoE System SHOULD support the ability to enable prefix prioritization such that the DPoE System would be able to:

- Prioritize converging all loopback prefixes (IPv4 /32s or IPv6 /128s) before all other prefix lengths.
- Prioritize converging prefixes tagged with certain value before all other prefixes.

The DPoE System SHOULD support the ability to configure a delay (hold timer) between the time a link-state change is detected and IS-IS runs the Djikstra algorithm.

The DPoE System SHOULD support the ability to configure a progressive backoff system for that delay with a max-wait value.

### 9.3.8 BGP

The DPoE System MUST support BGP [RFC 4271] for the distribution of route throughout an Autonomous System.

The DPoE System MUST support iBGP.

The DPoE System MUST be able to perform as a route reflector client as specified in [RFC 4456].

The DPoE System MUST be capable of operating as a BGP route reflector as specified in [RFC 4456].

The DPoE System MUST support iBGP peering with at least sixteen (16) peers.

The DPoE System MAY support BGP confederations [RFC 5065].

The DPoE System MUST implement BGP Support for Four-octet AS Number Space [RFC 4893].

The DPoE System MUST support the configuration of the standard two-octet BGP autonomous system number and the four-octet BGP autonomous system concurrently.

The DPoE System MUST support the MD5 signature option [RFC 2385].

The DPoE System MAY support the TCP Authentication Option for BGP [RFC 5925].

The DPoE System MUST support Graceful Restart Mechanism for BGP [RFC 4724].

The DPoE System SHOULD support BGP Route Dampening [RFC 2439].

The DPoE System MUST support Route Refresh Capability for BGP-4 [RFC 2918].

The DPoE System SHOULD support BGP Prefix Independent Convergence.

The DPoE System MUST support community tagging for announced and received prefixes with iBGP [RFC 1997].

The DPoE System MUST support community tagging with the BGP Extended Community Attribute [RFC 4360].

The DPoE System MUST support the concurrent tagging of at least sixteen (16) communities for each announced or received route for prefix for iBGP.

The DPoE System SHOULD support The Generalized TTL Security Mechanism (GTSM) [RFC 5082] for BGP.

### **9.3.8.1 MP-BGP Family Support**

The DPoE System MUST support the Multiprotocol Extensions for BGP-4 [RFC 4760].

The DPoE System MUST be configurable with an IPv4 peer address.

The DPoE System MUST be configurable with an IPv6 peer address.

The DPoE System MUST be able to recurse to an IPv4 BGP next-hop addresses for any supported MP-BGP address family.

The DPoE System MUST be able to recurse to an IPv6 BGP next-hop address for any supported MP-BGP address family.

The DPoE System MUST support the Use of BGP-4 Multiprotocol Extensions for IPv6 Inter-Domain Routing [RFC 2545].

The DPoE System MUST support Carrying Label Information in BGP-4 [RFC 3107].

The DPoE System MUST support Graceful Restart Mechanism for BGP with MPLS [RFC 4781].

The DPoE System MUST support MP-BGP family IPv4 Unicast.

The DPoE System MUST support MP-BGP family IPv4 Multicast.

The DPoE System MUST support MP-BGP family IPv4 Labeled Unicast.

The DPoE System MUST support MP-BGP family IPv6 Unicast.

The DPoE System MUST support MP-BGP family IPv6 Multicast.

The DPoE System MUST support MP-BGP family IPv6 Labeled Unicast.

The DPoE System MUST support MP-BGP family L2VPN.

The DPoE System MUST support peer group or neighbor group configurations to shorten and simplify BGP peering policy.

### **9.3.8.2 BGP Route Policy Requirements**

The DPoE System MUST support route policy controls including prefix filtering, filter lists, and route maps.

The DPoE System MUST support basic comparative logic for policy controls including at least:

- Less Than
- Less Than or Equal To
- Greater Than
- Greater Than or Equal To
- Equal To

The DPoE System SHOULD use VLSM or CIDR subnet length notation in the form of:

`/<masklen>`

Where <masklen> is the length of the subnetwork mask.

The DPoE System MUST support the following policy control settings:

- IP TOS
- DSCP
- Local Preference
- Metric
- Metric Type
- Weight
- Next Hop (NH)
- Origin
- Tag
- Traffic Index

The DPoE System MUST support blocking, filtering, suppression, aggregation, and summarization of IP routes based on BGP policy matches.

### 9.3.9 Multicast

Much of the multicast control plane that exists on the DPoE system is instrumented between the IP serving group and the CMCI. Those specific requirements, such as IGMPv2, IGMPv3, MLDv1, and MLDv2 are covered in [DPoE-MULPIv2.0], in [MULPIv3.0] and in this document under Section 9.5. The requirements between the DPoE System and the MSO network to request a multicast flow is specified below.

The DPoE System MUST support Source-Specific Multicast (SSM) for IP [RFC 4607].

The DPoE System MUST allow any prefix within the Class D (224.0.0.0/4) IPv4 address range to be configured as an SSM range.

The DPoE System MUST allow any IPv6 Multicast prefix within the FF00::/8 to be configured as an SSM range.

[RFC 4607] notes that the 232/8 is designated as the SSM range. Similarly [RFC 4607] notes that FF30::/32 is reserved for SSM use.

The DPoE System MUST allow a mechanism to change the default SSM range to any other prefix.

#### 9.3.9.1 Protocol Independent Multicast

The DPoE System MUST support Protocol Independent Multicast – Sparse Mode: Protocol Specification Revised [RFC 4601].

The DPoE System SHOULD support Anycast-RP Using Protocol Independent Multicast [RFC 4610].

The DPoE System SHOULD support Authentication and Confidentiality in Protocol Independent Multicast Sparse-Mode Link-Local Messages [RFC 5796].

The DPoE System MUST support Protocol Independent Multicast Routing in the Internet Protocol Version 6 as described in [RFC 4601].

The DPoE System SHOULD allow the configuration of static multicast groups such that the DPoE System always receives the configured multicast source and group (S,G) whether or not there are any downstream listeners – PIM or IGMP – who have requested that group.

The DPoE System SHOULD support configuration commands that enable SM group to SSM group mapping.

### **9.3.9.2 MP-BGP Multicast**

The DPoE System MUST be able to recurse to an IPv4 or an IPv6 BGP next-hop from a received advertisement for a BGP IPv4 or IPv6 family unicast or multicast prefix and generate the necessary PIM joins toward the Shortest Path Tree.

### **9.3.9.3 MPLS Multicast**

This specification does not include requirements for support of MPLS labeled multicast.

### **9.3.9.4 Multicast Troubleshooting Requirements**

The DPoE System MUST have a CLI command to display the PIM neighbors.

The DPoE System MUST have a CLI command to display the multicast routing table to display the selected Reverse Forward Path to the source and show all output interfaces in an output interface list for the specific multicast source, group in question.

The DPoE System MUST have a CLI command to display the multicast forwarding table which displays the ingress rate from the source interface and the egress rate toward each of the output interfaces in the output interface list for the multicast source, group in question.

The DPoE System SHOULD have a CLI command to display the number of PIM messages sent and received per logical interface per minute.

The DPoE System SHOULD have a CLI command to display the number of IGMP messages sent and received per logical interface per minute.

The DPoE System SHOULD have a CLI command to display the number of MLD messages sent and received per logical interface per minute.

## **9.3.10 Multi-Protocol Label Switching (MPLS)**

MPLS is defined in [RFC 3031], [RFC 3032], [RFC 3270], [RFC 3443], [RFC 5462] and [RFC 6178].

The DPoE System MUST support Multiprotocol Label Switching Architecture [RFC 3031].

The DPoE System MUST support MPLS Label Stack Encoding [RFC 3032].

The DPoE System MUST support Multi-Protocol Label Switching Support of Differentiated Services [RFC 3270].

The DPoE System MUST support Time To Live Processing in Multi-Protocol Label Switching Networks [RFC 3443].

The DPoE System MUST support Label Edge Router Forwarding of IPv4 Option Packets [RFC 6178].

The DPoE System MUST support MPLS label switching on the D and MNi interfaces.

The DPoE System MUST operate as an MPLS Label Edge Router and as an MPLS Label Switching Router.

The DPoE System MUST support LSP Ping and LSP Traceroute as defined in Detecting Multi-Protocol Label Switching (MPLS) Data Plane Failures [RFC 4379].

The DPoE System SHOULD support the appending of MPLS information to ICMP messages as defined in ICMP Extensions for Multi-Protocol Label Switching [RFC 4950].

The DPoE System MUST allow the operator to configure the mapping between the outer VLAN tag (PB or PBB Tag) PCP value and the MPLS Traffic Class value.

The DPoE System default MUST be that the values are copied from the outer VLAN tag PCP field directly into the MPLS Traffic Class field.

The DPoE System MUST perform this operation even if the DPoE System is removing the outer VLAN tag that carried the PCP value.

The DPoE System MUST perform this operation in the reverse direction when the DPoE system is adding the outer VLAN tag.

### **9.3.10.1 OSSI**

The DPoE System MUST support the Multiprotocol Label Switching (MPLS) Label Switching Router Management Information Base [RFC 3813]

The DPoE System MUST support the Multiprotocol Label Switching Forward Equivalence Class To Next Hop Label Forwarding Entry (FEC-To-NHLFE) Management Information Base [RFC 3814].

The DPoE System MUST support the Definition of Managed Objects for the Multiprotocol Label Switching Label Distribution Protocol [RFC 3815].

### **9.3.10.2 Label Distribution Protocol (LDP)**

The DPoE System MUST support Label Distribution Protocol (LDP) [RFC 5036] on the D and MNi interfaces.

The DPoE System SHOULD be configurable to operate in either Downstream on Demand or Downstream Unsolicited advertisement mode per logical interface.

The DPoE System MUST default to advertising only the LDP Forward Equivalence Class of host routes (/32s for IPv4 and /128s for IPv6.)

The DPoE System MUST provide a mechanism to allow the advertisement of LDP Forward Equivalence Class of all labeled prefixes.

The DPoE System SHOULD support TCP MD5 authenticity and integrity based on the use of the TCP MD5 Signature Option specified in [RFC 2385] per LDP neighbor.

The DPoE System SHOULD support Graceful Restart Mechanism for LDP [RFC 3478].

The DPoE System SHOULD support LDP Fast Reroute (FRR) as defined in a Basic Specification for IP Fast Reroute: Loop-Free Alternates [RFC 5286].

The DPoE System SHOULD support GTSM for LDP [RFC 5082].

### **9.3.10.3 IP/MPLS Debug**

The DPoE System MUST provide IP routing debug tools including:

- Local log and syslog for IP routing state changes for adjacencies
- Local log and syslog for LDP state changes for adjacencies.
- Local log and syslog for configuration changes that affect IP routing protocols

The DPoE System SHOULD provide IP routing debug tools including local log and syslog for IP routing "events", where an "event" is defined as a state change in an IP routing protocol.

The DPoE System SHOULD provide a configurable IP routing debug tool for "trace" capability for each IP routing protocol (independently). The IP routing debug tool SHOULD show received messages, state changes, parameters, and statistics in near real time to the console, to the local log, and to syslog (if logging is enabled for trace in the configuration for IP routing debug).

### **9.3.10.4 Virtual Private Wire Service**

The DPoE System MUST support "Pseudowire Emulation Edge to Edge (PWE3) Control Word for Use over an MPLS PSN" as defined in [RFC 4385].

The DPoE System MUST support [RFC 4447] "Pseudowire Setup and Maintenance Using the Label Distribution Protocol (LDP)".

The DPoE System MUST support "Encapsulation Methods for Transport of Ethernet over MPLS Networks" as defined in [RFC 4448].

The DPoE System MUST implement [RFC 5085] "Pseudowire Virtual Circuit Connectivity Verification (VCCV): A Control Channel for Pseudowires" to support MPLS CC Channel Types 1 and 3.

The DPoE System MUST implement [RFC 5085] "Pseudowire Virtual Circuit Connectivity Verification (VCCV): A Control Channel for Pseudowires" to support MPLS PW CV Types 1 (ICMP Ping) and 2 (LSP Ping).

The DPoE System MUST support "Flow Aware Transport of Pseudowires over an MPLS Packet Switched Network" as defined in [RFC 6391].

The DPoE System MUST provide a configurable Pseudowire Class object.

The DPoE System Pseudowire Class object name MUST be a configurable text string between 1 and 15 characters.

The DPoE System Pseudowire Class object MUST include the following configuration capabilities:

- PW MTU
- Pseudowire Type: 0x0004|0x0005
- Control Word: On|Off
- FAT PW: On|Off
- Pseudowire Redundancy Reversion: On|Off
- Pseudowire Redundancy Reversion Time:
- MAC-Withdraw: On|Off

#### **9.3.10.5 VPLS**

The DPoE System MUST support VPLS as defined in [RFC 4762], Virtual Private LAN Service (VPLS) Using Label Distribution Protocol (LDP) Signaling.

The DPoE System MUST support the Provisioning, Auto-Discovery, and Signaling in Layer 2 Virtual Private Networks as defined in [RFC 6074].

The DPoE System MUST implement MP-BGP Discovery for LDP-signaled VPLS.

The DPoE System MAY support VPLS as defined in [RFC 4761], Virtual Private LAN Service (VPLS) Using BGP for Auto-Discovery and Signaling.

The DPoE System MUST provide a configurable VPLS Class object.

The DPoE System VPLS Class object name MUST be a configurable text string between 1 and 15 characters.

The DPoE System VPLS Class object MUST include the following configuration capabilities:

- Per-VSI MAC Limit:
  - VSI Mac Limit Exceeded Action: Flood|Drop Unknown Unicast
- Per VSI MAC High Water Mark:
  - MAC Aging Time
  - VPLS MTU
  - Control Word: On|Off
  - VPLS MAC Address Withdrawal: On|Off
  - PW Type 0x0004|0x0005

The DPoE System VPLS Class object SHOULD include the following configuration capabilities:

- Learning: On|Off
- VSI PIM Snooping: On|Off

- VSI IGMP Snooping: On|Off
- Learning Mode: Qualified|Unqualified
- FAT PW: On|Off

## 9.4 Host Routing

The DPoE System typically treats IP(HSD) clients on the D-ONU CMCI interface as hosts on the DPoE System IP router.

### 9.4.1 IPv4 Host Routing

#### 9.4.1.1 ARP

The DPoE System **MUST** support ARP as defined in [RFC 826].

The DPoE System **SHOULD** support ARP throttling.

The DPoE System **SHOULD** support a defense mechanism against ARP spoofing, ARP cache poisoning, or ARP poison routing attacks such as ARP Security or Dynamic ARP Inspection.

The DPoE System **MUST** be configurable to disable Address Resolution Protocol (ARP) individually for each IPv4 interface on the DPoE System.

#### 9.4.1.2 IGMP

The DPoE System **MUST** support Internet Gateway Multicast Protocol (IGMP) version 2 [RFC 2236].

The DPoE System **MUST** support IGMP version 3 [RFC 3376].

The DPoE System **MUST** support IGMP version 3 for Source Specific Multicast [RFC 4605].

The DPoE System **SHOULD** provide a CLI and configuration file mechanism to rate limit the number of received IGMP messages per minute.

The DPoE System **SHOULD** provide a CLI command to show the number of IGMP messages received per minute.

The DPoE System **MUST** provide a CLI command to display all IGMP clients currently requesting a specific multicast group or source and multicast group.

The DPoE System **MUST** provide a CLI command to display all IGMP clients currently requesting a specific multicast group or source and multicast group for which they are not authorized.

### 9.4.2 IPv6 Host Routing

#### 9.4.2.1 Address Discovery

The DPoE System **MUST** support IPv6 neighbor discovery protocol (NDP) [RFC 2461].

The DPoE System **SHOULD** support NDP throttling.

The DPoE System **SHOULD** support a defense mechanism against NDP spoofing.

The DPoE System **SHOULD** support Secure Neighbor Discovery [RFC 3971].

The DPoE System **MUST** be configurable to disable NDP individually for each IPv6 interface on the DPoE System.

The DPoE System **MUST** support stateless address autoconfiguration (SLAAC) [RFC 4862].

The DPoE System **MUST** support IPv6 Prefix Delegation as described in [RFC 3769].

### 9.4.2.2 MLD

The DPoE System MUST support Multicast Listener Discovery (MLD) version 1 for IPv6 [RFC 2710].

The DPoE System MUST support MLD version 2 for IPv6 [RFC 3810].

The DPoE System MUST support Source Address Selection for the MLD protocol [RFC 3590].

The DPoE System MUST provide a CLI command to display all MLD clients currently requesting a specific multicast group or source and multicast group.

The DPoE System MUST provide a CLI command to display all MLD clients currently requesting a specific multicast group or source and multicast group for which they are not authorized.

## 9.5 CMCI Routing

A DPoE System MUST support Routing Information Protocol version 2 (RIPv2) [RFC 2453] for dynamic IP address learning from a CPE running RIP.

The DPoE System MUST support BGP-4 for dynamic IP address learning from a CPE running BGP-4.

The DPoE System MUST act as an IP router (peer) to the CPE running RIP.

A DPoE System MUST provide RIPv2 Cryptographic Authentication [RFC 4822].

A DPoE System MUST support Routing Information Protocol next generation (RIPng) [RFC 2080].

As RIPng operates over IPv6, RIPng relies on the IPv6 Authentication Header as defined in [RFC 2402] rather than a separate RIP Cryptographic Authentication mechanism as defined for RIPv2.

The DPoE System MUST support static IPv4 routing to next-hops connected to the CMCI interface.

The DPoE System MUST support static IPv6 routing to next-hops connected to the CMCI interface.

The DPoE System MUST support source policy based routing for IPv4 source addresses where the packets arrive on the TUL.

The DPoE System MUST support source policy based routing for IPv6 source addresses where the packets arrive on the TUL.

This version of the specification does not automate RIPv2, RIPng, or static route configuration.

## 9.6 VCM Host Provisioning

The DPoE System MUST have a CLI command to set the default vCM provisioning mode to IPv4-only or IPv6-only.

If this value is not set via CLI, the DPoE System MUST make the default vCM provisioning mode IPv4-only.

## 9.7 Network Timing Support

Network timing and clock are increasingly becoming a fundamental requirement for Ethernet services and for emulated services over an Ethernet or IP-based transport. Synchronous Ethernet [G.8262/Y.1362] and [1588v2] are two examples of such timing protocols. This section details the configuration and feature requirements for high precision network-based time of day, phase, and frequency synchronization.

The DPoE System MUST support [1588v2] as a boundary clock.

The DPoE System MAY support [G.8262/Y.1362].

---

<sup>19</sup> Revised per IPNEv2.0-N-14.0166-2 on 7/11/14 by JB.



### 9.7.1 Network Timing Profile

The timing configuration (i.e., [1588v2]) to a CMCI on a D-ONU is instrumented via CM configuration file TLV defined in [DPoE-MULPIv2.0] (Timing Profile Name TLV73.1) that associates a specific CMIM to a Timing configuration profile configured locally on the DPoE System.

The DPoE System **MUST** provide configuration to enable 1588v2 to support ToD, phase and frequency on the D-ONU.

The following is a CLI example for the timing profile – this timing profile is referenced by CM configuration TLV 73.1:

```
Timing profile name
  Domain [DOMAIN_ID]
  TOD format [FORMAT]
  Protocol enable
    SyncE
    1588v2
```

The DPoE System configurable Timing Profile Name **MUST** be a string of 2 to 16 characters to align with TLV 73.1 as defined in [DPoE-MULPIv2.0].

### 9.7.2 Global Timing Configuration

The DPoE System **MUST** have a configuration to support an IP-based [1588v2] connection to a grandmaster clock for a single configured domain.

The DPoE System **SHOULD** support the configuration of at least four timing domains with redundant connections to grandmaster clocks for each of those domains.

To operate network time protocols across EPON at a great precision, +-50ns for example, an operator may need to adjust the  $N_{up}/N_{down}$  parameters (described in [DPoE-MULPIv2.0]). The  $N_{up}/N_{down}$  essentially provides the refractive index across the fiber optic medium at a specific wavelength. The table below provides informative suggested refractive indexes across a common fiber optic medium for EPON.

**Table 3 - Index of Refraction for Common EPON Fiber Optic Media**

Fiber Medium	Wavelength	Refractive Index ( $N_{up}/N_{down}$ )
SMF-28e	1260nm	1.46682
SMF-28e	1310nm	1.46692
SMF-28e	1490nm	1.46728
SMF-28e	1550nm	1.4674
SMF-28e	1570nm	1.467454

The DPoE System **MUST** support a configuration object to adjust the  $N_{up}/N_{down}$  per TUL.

## Appendix I CMTS Example Configuration File A (Informative)

Following is the majority of a complete configuration file for a typical DOCSIS 2.0 CMTS used in production today. When <angle brackets> are used, the actual text in the configuration file varies among operators or was removed to make the configuration generic to all operators. Other comments indicate if other sections were purposefully omitted to keep the example brief and readable.

```

!!!!
!
! DOCSIS 2.0 Example Configuration File A
!
!!!!
no service pad
service timestamps debug datetime
service timestamps log datetime
service password-encryption
service sequence-numbers
!
hostname <hostname>.<Site Name>.<State>
!
boot-start-marker
boot system flash <device name>:<image name.bin>
boot system flash
!
no logging console
enable secret
!
aaa new-model
aaa authentication login default group radius local
aaa authorization config-commands
aaa authorization exec default group tacacs+ none
aaa authorization commands 15 default group tacacs+ none
aaa accounting exec default start-stop group tacacs+
aaa accounting commands 0 default stop-only group tacacs+
aaa accounting commands 1 default stop-only group tacacs+
aaa accounting commands 15 default stop-only group tacacs+
aaa accounting system default start-stop group tacacs+
!
cable admission-control preempt priority-voice
cable flap-list aging 1440
cable modem max-cpe 6
cable modem vendor 00.<nn>.<nn> "Vendor Name"
! additional cable modem vendor <nn>.<nn>.<nn> "Vendor Name" for each MAC range for each vendor
!
! Modulation profiles (omitted)
!
cable service class 100 name
cable service class 100 upstream
cable service class 100 tos-overwrite 20 20
cable service class 100 priority 1
cable service class 100 max-rate <Peak Rate>
cable service class 100 max-burst <PB Bucket Size>
cable service class 100 max-concat-burst 3044
cable service class 101 name
cable service class 101 downstream
cable service class 101 priority 1
cable service class 101 max-rate <Peak Rate>
cable service class 101 max-burst <PB Bucket Size>
cable service class 102 name
cable service class 102 upstream
cable service class 102 tos-overwrite 20 20
cable service class 102 priority 1
cable service class 102 max-rate <Peak Rate>
cable service class 102 max-burst <PB Bucket Size>
cable service class 102 max-concat-burst 4096
cable service class 103 name
cable service class 103 downstream
cable service class 103 priority 1
cable service class 103 max-rate <Peak Rate>
cable service class 103 max-burst <PB Bucket Size>

```

```
cable service class 104 name
cable service class 104 upstream
cable service class 104 tos-overwrite 20 20
cable service class 104 priority 1
cable service class 104 max-rate <Peak Rate>
cable service class 104 max-burst <PB Bucket Size>
cable service class 104 max-concat-burst 16384
cable service class 105 name
cable service class 105 downstream
cable service class 105 priority 1
cable service class 105 max-rate <Peak Rate>
cable service class 105 max-burst <PB Bucket Size>
!
cable service class 106 name
cable service class 106 upstream
cable service class 106 tos-overwrite 20 20
cable service class 106 priority 0
cable service class 106 max-rate <Peak Rate>
cable service class 106 max-burst <PB Bucket Size>
cable service class 106 max-concat-burst 3044
cable service class 107 name
cable service class 107 downstream
cable service class 107 priority 0
cable service class 107 max-rate <Peak Rate>
cable service class 107 max-burst <PB Bucket Size>
cable service class 108 name
cable service class 108 upstream
cable service class 108 tos-overwrite 20 20
cable service class 108 priority 0
cable service class 108 max-rate <Peak Rate>
cable service class 108 max-burst <PB Bucket Size>
cable service class 108 max-concat-burst 4096
cable service class 109 name
cable service class 109 downstream
cable service class 109 priority 0
cable service class 109 max-rate <Peak Rate>
cable service class 109 max-burst <PB Bucket Size>
cable service class 110 name
cable service class 110 upstream
cable service class 110 tos-overwrite 20 20
cable service class 110 priority 0
cable service class 110 max-rate <Peak Rate>
cable service class 110 max-burst <PB Bucket Size>
cable service class 110 max-concat-burst 16384
cable service class 111 name
cable service class 111 downstream
cable service class 111 priority 0
cable service class 111 max-rate <Peak Rate>
cable service class 111 max-burst <PB Bucket Size>
cable service class 112 name
cable service class 112 upstream
cable service class 112 tos-overwrite 20 20
cable service class 112 priority 1
cable service class 112 max-rate <Peak Rate>
cable service class 112 max-burst <PB Bucket Size>
cable service class 112 max-concat-burst 16384
cable service class 113 name
cable service class 113 downstream
cable service class 113 priority 1
cable service class 113 max-rate <Peak Rate>
cable service class 113 max-burst <PB Bucket Size>
cable service class 114 name
cable service class 114 upstream
cable service class 114 tos-overwrite 20 20
cable service class 114 priority 0
cable service class 114 max-rate <Peak Rate>
cable service class 114 max-burst <PB Bucket Size>
cable service class 114 max-concat-burst 16384
cable service class 115 name
cable service class 115 downstream
cable service class 115 priority 0
cable service class 115 max-rate <Peak Rate>
```

```
cable service class 115 max-burst <PB Bucket Size>
!
cable service class 122 name
cable service class 122 upstream
cable service class 122 max-concat-burst 8192
cable service class 122 tos-overwrite 20 20
cable service class 122 max-rate <Peak Rate>
cable service class 122 max-burst <PB Bucket Size>
cable service class 122 priority 1
cable service class 123 name
cable service class 123 downstream
cable service class 123 max-rate <Peak Rate>
cable service class 123 max-burst <PB Bucket Size>
cable service class 123 priority 1
cable service class 124 name
cable service class 124 upstream
cable service class 124 max-concat-burst 8192
cable service class 124 tos-overwrite 20 20
cable service class 124 max-rate <Peak Rate>
cable service class 124 max-burst <PB Bucket Size>
cable service class 124 priority 0
cable service class 125 name
cable service class 125 downstream
cable service class 125 max-rate <Peak Rate>
cable service class 125 max-burst <PB Bucket Size>
cable service class 125 priority 0
!
cable service class 126 name
cable service class 126 upstream
cable service class 126 max-concat-burst 8192
cable service class 126 tos-overwrite 20 20
cable service class 126 max-rate <Peak Rate>
cable service class 126 max-burst <PB Bucket Size>
cable service class 126 priority 1
cable service class 127 name
cable service class 127 downstream
cable service class 127 max-rate <Peak Rate>
cable service class 127 max-burst <PB Bucket Size>
cable service class 127 priority 1
cable service class 128 name
cable service class 128 upstream
cable service class 128 max-concat-burst 8192
cable service class 128 tos-overwrite 20 20
cable service class 128 max-rate <Peak Rate>
cable service class 128 max-burst <PB Bucket Size>
cable service class 128 priority 0
cable service class 129 name
cable service class 129 downstream
cable service class 129 max-rate <Peak Rate>
cable service class 129 max-burst <PB Bucket Size>
cable service class 129 priority 0
!
cable service class 130 name
cable service class 130 upstream
cable service class 130 tos-overwrite 28 28
cable service class 130 priority 2
cable service class 131 name
cable service class 131 upstream
cable service class 131 tos-overwrite 58 58
cable service class 131 priority 2
cable service class 132 name
cable service class 132 upstream
cable service class 132 tos-overwrite b8 b8
cable service class 132 priority 2
cable service class 133 name
cable service class 133 downstream
cable service class 133 priority 2
!
cable service class 134 name
cable service class 134 downstream
cable service class 134 max-rate 13200000
cable service class 134 max-burst 3044
```

```

cable service class 134 priority 1
cable service class 135 name
cable service class 135 upstream
cable service class 135 max-concat-burst 3044
cable service class 135 tos-overwrite 70 70
cable service class 135 max-rate 2200000
cable service class 135 max-burst 3044
cable service class 135 priority 1
!Legacy
cable service class 201 name
cable service class 201 upstream
cable service class 201 tos-overwrite 20 20
cable service class 201 priority 1
cable service class 202 name
cable service class 202 upstream
cable service class 202 tos-overwrite 70 70
cable service class 202 priority 1
!DMCA Notification
cable service class 203 name
cable service class 203 upstream
cable service class 203 tos-overwrite 0 24
cable service class 203 max-rate 1000000
cable service class 203 max-burst 3044
cable service class 203 priority 1
!
no cable qos permission create
no cable qos permission update
cable qos permission modems
cable multicast group-encryption 1 algorithm 56bit-des
cable multicast group-qos default scn def_sclass aggregate
!
cable submgmt default filter-group cpe upstream 2
cable submgmt default filter-group cpe downstream 1
cable submgmt default filter-group cm upstream 4
cable submgmt default filter-group cm downstream 3
cable submgmt default filter-group mta upstream 10
cable submgmt default filter-group mta downstream 9
cable submgmt default filter-group ps upstream 2
cable submgmt default filter-group ps downstream 1
cable submgmt default active
cable default-tos-qos10 tos-overwrite 0x20 0x20
cable load-balance group 1 threshold load 3
cable load-balance group 1 threshold load minimum 1
cable load-balance group 2 threshold load 3
cable load-balance group 2 threshold load minimum 1
cable load-balance group 3 threshold load 3
cable load-balance group 3 threshold load minimum 1
!
cable sflog max-entry 59999 entry-duration 3600
cable metering destination <IPDR coll IP Addr> 2000 2 15 non-secure
cable metering source-interface loopback 0
!
ip subnet-zero
no ip source-route
no ip gratuitous-arps
ip telnet source-interface Loopback0
ip tcp path-mtu-discovery
no ip finger
!
ip tftp source-interface Loopback0
ip ftp source-interface Loopback0
no ip domain lookup
ip domain-name <state.operator.net>
ip name-server
ip name-server
ip dhcp relay information option
no ip dhcp relay information check
!
no ip bootp server
crypto key generate rsa general-keys modulus 1024
ip ssh time-out 60
packetcable

```

```
packetcable multimedia
multilink bundle-name authenticated
call rsvp-sync
!
key chain ubr-rip
  key 1
    key-string 7
username <name> <password>
access-list 20 remark For SNMP
!
no crypto isakmp enable
!
buffers small permanent 1000
buffers small max-free 1500
buffers middle permanent 1000
buffers middle max-free 1500
!
interface Loopback0
  ip address <Loopback IP> 255.255.255.255
!
interface GigabitEthernet0/1
  description <remote side interface/port>
  ip address <IP address & subnet mask>
  no ip redirects
  no ip unreachableables
  no ip proxy-arp
  ip ospf hello-interval 1
  ip ospf network point-to-point
  ip ospf cost <1 for the Sandvine interface, 3 for the other>
  load-interval 30
  no ip mroute-cache
  duplex full
  speed 1000
  media-type <gbic or rj45>
  no negotiation auto
  hold-queue 1024 in
  hold-queue 1024 out
!
interface GigabitEthernet0/2
  description <remote side interface/port>
  ip address <IP address & subnet mask>
  no ip redirects
  no ip unreachableables
  no ip proxy-arp
  ip ospf hello-interval 1
  ip ospf network point-to-point
  ip ospf cost <1 for the xxxxx interface, 3 for the other>
  load-interval 30
  no ip mroute-cache
  duplex full
  speed 1000
  media-type <gbic or rj45>
  no negotiation auto
  hold-queue 1024 in
  hold-queue 1024 out
!
interface GigabitEthernet0/3
  no ip address
  shutdown
  duplex auto
  speed auto
  media-type rj45
  no negotiation auto
!
interface Bundle10
  ip address <secondary subnet and mask> secondary
  ip address <primary subnet and mask>
  ip rip receive version 2
  ip rip authentication mode md5
  ip rip authentication key-chain ubr-rip
  no cable arp filter request-send
  no cable arp filter reply-accept
```

```
ip igmp access-group 70
cable source-verify dhcp
cable dhcp-parse option-43
cable dhcp-parse option-60
cable dhcp-giaddr primary
cable helper-address <helper address>
cable helper-address <helper address>
!
router ospf 65300
router-id <loopback 0 IP address>
log-adjacency-changes
redistribute rip metric 20 metric-type 1 subnets route-map COMM-SVC-NETS
passive-interface default
no passive-interface GigabitEthernet0/1
no passive-interface GigabitEthernet0/2
network 0.0.0.0 255.255.255.255 area 1
!
router rip
version 2
passive-interface default
network <ip network>
network <ip network>
network <ip network>
distribute-list 35 in bundle10
no auto-summary
!
ip classless
no ip http server
no ip http secure-server
ip tacacs source-interface Loopback0
!
ip radius source-interface Loopback0
logging trap notifications
logging facility local6
logging source-interface Loopback0
logging
!
nls resp-timeout 1
cpd cr-id 1
route-map COMM-SVC-NETS permit 35
match ip address 35
!
snmp-server trap-source Loopback0
snmp-server view reset-view cdxCmCpeEntry.8 included
snmp-server view set-utilization-mib docsIfCmtsObjects.8 included
snmp-server community view block_bad_mib RO 20
snmp-server community view block_bad_mib RW 20
snmp-server view block_bad_mib iso included
snmp-server view block_bad_mib docsQosPHSEntry excluded
snmp-server view block_bad_mib ccqmEnfRuleViolateEntry excluded
snmp-server view block_bad_mib ccqmCmtsIfBwUtilEntry excluded
snmp-server view block_bad_mib ccacUsConfigRevEntry excluded
snmp-server view block_bad_mib ccacUsRevEntry excluded
snmp-server view block_bad_mib ccacDsRevEntry excluded
snmp-server community view set-utilization-mib RW 20
snmp-server community view reset-view RW 21
snmp-server location <location name>
snmp-server contact <location contact>
snmp-server queue-length 20
snmp-server chassis-id <chassis host name>
snmp-server enable traps snmp linkdown linkup coldstart warmstart
no snmp-server enable traps tty
no snmp-server enable traps config
snmp-server enable traps entity
snmp-server enable traps envmon shutdown supply temperature voltage
no snmp-server enable traps cable
snmp-server enable traps rtr
snmp-server enable traps alarms major
snmp-server host <NOC Trap Server #1>
snmp-server host <NOC Trap Server #2>
tacacs-server host
tacacs-server host
```

```

tacacs-server key 7
radius-server host auth-port 1645 acct-port 1646 key 7
radius-server host auth-port 1645 acct-port 1646 key 7
radius-server retransmit 0
radius-server timeout 3
radius-server authorization permit missing Service-Type
cops listener access-list vty-access
banner motd ^C
*****
WARNING

This system is solely for the use of authorized <operator> employees and
<>

LOCATION : Site name, State

*****^C
privilege exec level 0 squeeze
privilege exec level 0 slip
privilege exec level 0 systat
privilege exec level 0 ping docsis
privilege exec level 0 ping
privilege exec level 0 send
privilege exec level 5 terminal monitor
privilege exec level 0 terminal length
privilege exec level 0 terminal
privilege exec level 0 show interfaces Cable6/1 modem
privilege exec level 0 show interfaces Cable6/1 sid
privilege exec level 0 show interfaces Cable6/0 modem
privilege exec level 0 show interfaces Cable6/0 sid
privilege exec level 0 show interfaces Cable5/1 modem
privilege exec level 0 show interfaces Cable5/1 sid
privilege exec level 0 show interfaces Cable5/0 modem
privilege exec level 0 show interfaces Cable5/0 sid
privilege exec level 0 show interfaces Cable4/1 modem
privilege exec level 0 show interfaces Cable4/1 sid
privilege exec level 0 show interfaces Cable4/0 modem
privilege exec level 0 show interfaces Cable4/0 sid
privilege exec level 0 show interfaces Cable3/1 modem
privilege exec level 0 show interfaces Cable3/1 sid
privilege exec level 0 show interfaces Cable3/0 modem
privilege exec level 0 show interfaces Cable3/0 sid
privilege exec level 0 show interfaces
privilege exec level 0 show
privilege exec level 0 clear cable host
privilege exec level 0 clear cable
privilege exec level 0 clear
privilege exec level 0 show cable flap-list sort-flap
privilege exec level 0 show cable flap-list Cable6/1 sort-flap
privilege exec level 0 show cable flap-list Cable6/0 sort-flap
privilege exec level 0 show cable flap-list Cable5/1 sort-flap
privilege exec level 0 show cable flap-list Cable5/0 sort-flap
privilege exec level 0 show cable flap-list Cable4/1 sort-flap
privilege exec level 0 show cable flap-list Cable4/0 sort-flap
privilege exec level 0 show cable flap-list Cable3/1 sort-flap
privilege exec level 0 show cable flap-list Cable3/0 sort-flap
privilege exec level 0 show cable flap-list
privilege exec level 0 show cable modem
privilege exec level 0 show cable qos profile
privilege exec level 0 show cable qos
privilege exec level 0 show cable
!
line con 0
 session-timeout 15 output
 stopbits 1
line aux 0
 no exec
line vty 0 4
 access-class vty-access in
 session-timeout 15 output
 transport input all
line vty 5 15

```



```
access-class vty-access in
session-timeout 15 output
transport input all
!
scheduler allocate 4000 400
ntp access-group peer 40
ntp source Loopback0
ntp update-calendar
ntp server
ntp server
end
```

## Appendix II CMTS Example Configuration B (Informative)

### II.1 CMTS Example Configuration B File with Explanations

Following is the majority of a complete configuration file for a typical DOCSIS 1.1 CMTS used in production today with explanatory text added following each bang "!" symbol. When <angle brackets> are used, the actual text in the configuration file varies among operators or was removed to make the configuration generic to all operators. Other comments indicate if other sections were purposefully omitted to keep the example brief and readable.

```

!!!!
!
! DOCSIS 1.1 Example Configuration File B
!
!!!!
no service single-slot-reload-enable
service nagle
service sequence-numbers
no service pad
service timestamps debug datetime msec localtime show-timezone
service timestamps log datetime msec localtime show-timezone
service password-encryption
no ip bootp server
no ip gratuitous-arps
no service tcp-small-servers      ! default, does not show in
! configuration
no service udp-small-servers      ! default, does not show in
! configuration
no scheduler heapcheck process    ! default, does not show in
! configuration.  If enabled, will
! show towards the end of the
! configuration
scheduler allocate 4000 400      ! Improves processing of interrupts
! when large numbers of modems are
! online; default 4000 400
no ip forward-protocol udp        ! improve modem registration times
hostname <local Hostname>        ! local hostname
!
boot system flash disk: <image name>.bin
boot bootldr bootflash: <image name>.bin
!
! TACACS Configuration
hostname <hostname>
no ip domain lookup
ip domain name <domain name>.<sub-domain>.com
aaa new-model
!
! SSH Enable
crypto key zeroize rsa
crypto key generate rsa
line vty 0 15
transport input all
transport output all
!
! Global Cable Commands
! The following command causes the CMTS to enforce a MAX-CPE value of 10 for each cable modem.  If a
value
! greater than 10 is specified in the modem configuration file, the higher value will be enforced.
Note: The
! default value of 1 for max-cpe will not show in the running configuration.
! cable modem max-cpe 10
no cable qos permission create      ! default IOS entries
no cable qos permission update
cable qos permission modems
ip dhcp relay information option     ! Insert relay information in DHCP
! This following command modifies the non-packetcable DOCSIS 1.1 service flow timeout behavior.  It
allows a
! user-definable Active QoS Timeout to be set from the CMTS to prevent stale service flows.  See Cisco
! documentation for detailed information on this configurable timer.
cable service flow activity-timeout 300

```

```
!  
! Buffer Configuration  
! The following configurations more optimally tune the buffers than that of default such that buffer  
failures  
! are minimized:  
buffers small permanent 310  
buffers small max-free 515  
buffers small min-free 65  
buffers middle permanent 258  
buffers middle max-free 360  
buffers middle min-free 80  
buffers big permanent 528  
buffers big max-free 828  
buffers big min-free 180  
buffers verybig permanent 42  
buffers verybig max-free 43  
buffers verybig min-free 6  
!  
! Flap-List Configuration  
! The following configuration tunes the operation of the flap-list command.  
cable flap-list insertion-time 180  
cable flap-list power-adjust threshold 3  
! Power adjust using different |thresholds requires a locally |created CR and should be |temporary  
until the  
! plant has |been stabilized.  
cable flap-list aging 1440  
cable flap-list size 8191  
!  
! Network Time  
! omitted from this example  
!  
! Global Routing Commands  
ip subnet-zero  
no ip source-route  
ip cef  
ip classless  
!  
! Name Resolution  
no ip finger  
ip domain-lookup          ! Default, does not show in  
! configuration  
ip domain-name <local domain name>  
ip name-server <primary server> | Only one name server  
!  
! Multicast Routing  
ip multicast-routing  
ip multicast route-limit 250  
  no cable ip-multicast-echo      ! default, does not show in  
! configuration  
!  
! Route Authentication Key Strings  
key chain ubr-rip          ! Key string for Static IP Solution  
  key 1  
    key-string <key string 1>  
  key 2  
    key-string <key string 2>  
! Note: Multiple key strings are supported. Key ID must match. Key-string should be 16 alphanumeric  
characters ! or less.  
!  
! Generic Interface Configuration  
interface <interface name and index>  
  description <description>      ! include destination and circuit ID info if applicable  
  no ip directed-broadcast      ! Does not show in running-config  
  no ip proxy-arp  
  no ip redirects  
  keepalive  
  no ip mroute-cache  
!  
! Loopback Interface Configuration  
! The loopback interface is a virtual interface that is independent of all hardware interfaces. Since  
this
```

```

! interface will always be "up", it is used by SNMP and routing protocols to gather information. The
netmask
! should be /32. The Description text should include serial number, model of router, local contact and
contact
! phone number, and the location of the equipment. It is not necessary to include the generic interface
! configuration on a loopback as all commands are not fully supported nor needed.
!
interface loopback0
description <s/n, Contact, phone #, location>
ip address <ip address> <netmask>
!
! Fast Ethernet Interface Configuration
! The following commands apply only to the Fast Ethernet port on the uBR's I/O controller.
interface fastethernet 0/0
duplex full      ! Ensure hub or switch is set to full duplex
ip ospf cost 20 ! Needed to ensure fastethernet is
! not used for transit traffic |(except when used for legacy      | equipment or uBR to uBR
|
! connections)
!
! NPE-G1 Gigabit Ethernet Interfaces
! The following commands apply only to the 3 onboard Gigabit Ethernet interfaces on the NPE-G1
processor. If
! you want to use these interfaces to replace the Fast Ethernet interfaces on the existing I/O
controller, you
! will have to configure the new interfaces before they can be used to access the network. If you are
also
! removing the existing I/O controller, you will need to remove the configuration for its Fast Ethernet
! interfaces. Note, The RJ-45 ports and GBIC ports are both reported in software as GigabitEthernet
0/1,
! GigabitEthernet 0/2, and GigabitEthernet 0/3. Only one of the pair of interface ports can be used at
a time.
! For example, you can use either the GBIC 0/2 port or the RJ-45 0/2 port, but not both. All generic
interface
! configurations still apply but are not shown below (e.g. ospf cost, priority).
!
interface GigabitEthernet<slot/port> ! Configure for FastEthernet
! using rj45
duplex full      ! Force full duplex operation
speed 100        ! Force 100 Mbps operation
media-type rj45 ! Set media to use rj45
no negotiation auto
!
interface GigabitEthernet<slot/port> ! Configure for Gigabit Ethernet
! using gbic
duplex full      ! Force full duplex operation
speed 1000       ! Force 1000 Mbps operation
media-type gbic ! Set media to use gbic
no negotiation auto
!
! Dedicated Access
! The dedicated access solution for commercial services customers using the 3550 can be connected
directly as a ! Fast Ethernet connection to one of the GigabitEthernet ports available on the NPE-G1.
This connection MUST
! be configured as FastEthernet only provided the following conditions are met:
! 1.   Hubsite must not have an existing aggregation router connected to the distribution network,
i.e.
! 10720, 75XX, or 12XXX.
! 2.   CMTS must have an NPE-G1 processor running at a n monthly max CPU five minute average of less
than 50%
! (as reported by MRTG).
! 3.   Uplink to CMTS is limited to a single full-duplex 100Mb/sec FastEthernet segment. GE is not
permitted.
! Standard OSPF configurations still apply.
!
! Generic Cable Interface Configuration
interface Cable <slot>/<port> ! Commands should be repeated for all cable interfaces.
!
no ip unreachable      | To prevent unnecessary ICMP replies
no cable ip-multicast-echo | Disable multicast echoing( on all master bundles.
!
cable shared-secret <z> <authen-key string>

```

```

! Used to reduce theft of service by non-subscribers. It works by using a single shared-secret key
configured
! in both the CMTS and the DOCSIS config file that is sent down to cable modems prior to them coming
online
!
cable map-advance dynamic      !re-enable dynamic map advance on
                               !all line cards. This command is the
                               !default and does not show in the
                               ! running configuration.
!
cable arp filter request-send 4 2
cable arp filter reply-accept 4 2      !ARP filtering limits ARP traffic per SID. This must be
configured on all downstream interfaces including both master and slave interfaces
! Cable Interface Downstream Configuration (without Bundling)
interface cable <ds interface>/0      ! Commands should be repeated for all interfaces.
! Each cable interface should be configured with at least one primary and one secondary address. The
primary
! address must always be used for cable modems. The secondary addresses are used for customer premise
! equipment. Please contact <> if your configuration does not match this standard.
! Under circumstances when the primary cable modem scope becomes insufficient to support all devices
and needs
! to be expanded, a secondary CM scope may be configured to allow for additional growth. The <>
operations
! manual should be consulted for configuration guidelines.
! All ingress interfaces should be configured to verify the reverse path of incoming packets. This is
done to
! prevent "spoofing" attacks. Ingress interfaces would be those interfaces, which connect the Road
Runner
! network to either customers or other public networks. This is different from the "cable source-
verify"
! feature, however the two perform a similar function.
!
! Multinet
ip address <address> <mask> secondary  | CM (secondary added for growth)
ip address <address> <mask> secondary  | CPE (secondary)
ip address <address> <mask>          | Cable Modem (primary)
!
cable insertion-interval automatic
cable dhcp-giaddr primary          ! If this is not the case, please
!
ip verify unicast reverse-path allow-self-ping
cable helper-address <primary cpe dhcp server> host
cable helper-address <secondary cpe dhcp server> host
cable helper-address <primary cm dhcp server> cable-modem
cable helper-address <secondary cm dhcp server> cable-modem
!
! RIP
ip rip authentication mode md5
ip rip authentication key-chain <key string name>
default cable downstream rate-limit      ! Does not show in configuration
cable downstream annex B
!
! The downstream modulation may be set to either 64QAM or 256QAM depending on the capabilities of the
local RF
! plant (256qam is the preferred setting). Please contact <> before changing from 64QAM to 256QAM due
to the
! increased carrier to noise ratio requirements.
! cable downstream modulation <64qam or 256qam> | 256qam preferred
cable downstream interleave-depth 32
cable downstream frequency <ds frequency>      | Note this is a comment only and
cable privacy kek life-time 604800            | Default, does not show in
cable privacy kek grace-time 600              | Default, does not show in
cable privacy tek life-time 43200             | Default, does not show in
cable privacy tek grace-time 600              | Default, does not show in
!
no cable downstream rf-power
! Cable Interface Downstream Configuration (with Bundling)
! Cable Interface Bundling allows multiple interfaces to share a single IP network number. A given
CMTS may
! have multiple bundles depending on the number of hosts per interface. For example, a newly deployed
CMTS

```

```

! could have all four interfaces in a single bundle.  If after a period of time, the user population
could be
! segmented into two groups of 500 to 700 users, each using two interfaces, it would be more efficient
to split
! the configuration into two bundles.  The commands used with Interface Bundling are identical to
those used
! without Interface Bundling with some minor exceptions.
! The bundled interfaces must be assigned to a Virtual Bundle by the commands:
interface cable <ds interface>/0
cable bundle <bundle id>
! The remaining configuration of the bundled interfaces would be identical to the configuration used on
the
! unbundled interface without the layer-3 configurations such as:
! 1.  IP addresses are not required
! 2.  Cable Helper addresses are not required
! 3.  RIPv2 authentication is not required
! 4.  Source-Verify and Lease-Timer functions
! 5.  PIM
! 6.  Access-lists (ACLs)
! 7.  Sub-interfaces
! 8.  Cable ARP filters
! The upstream configuration does not change in any way if bundling is enabled.
!
! Virtual Bundle Interface
! In IOS 12.3(17b)BC4, Virtual Bundle Interface supports bundled cable interfaces to allow multiple
cable ! interfaces to share a single IP network number.  Virtual interface bundling supports and
governs the following ! Layer 3 settings for the bundle member interfaces:
! 1.  IP address scopes
! 2.  Cable Helper addresses
! 3.  RIPv2 authentication
! 4.  Source-Verify and Lease-Timer functions
! 5.  PIM
! 6.  Access-lists (ACLs)
! 7.  Sub-interfaces
! 8.  Cable ARP filters
! Ex:
interface Bundle1
    ip address 10.200.200.1 255.255.255.0 secondary
    ip address 10.200.111.1 255.255.255.0 secondary
    ip address 10.200.112.1 255.255.255.0 secondary
    ip address 24.28.219.1 255.255.255.128 secondary
    ip address 10.200.2.1 255.255.255.0
    ip verify unicast reverse-path allow-self-ping
    ip rip send version 2
    ip rip receive version 2
    ip rip authentication mode md5
    ip rip authentication key-chain ubr-rip
    ip pim sparse-mode
    cable arp filter request-send 4 2
    cable arp filter reply-accept 4 2
    no cable ip-multicast-echo
    cable dhcp-giaddr primary
    cable helper-address 10.203.3.6
!
! The bundled cable interfaces must be assigned to a Virtual Bundle by the commands:
interface cable <ds interface>/0
cable bundle <bundle id>
!
interface Cable3/0
cable bundle 1
!
interface Cable3/1
    cable bundle 1
!
! Cable Interface Upstream Configuration
cable upstream <us channel> description <Fiber Node(s) connected>
cable upstream <us channel> frequency <us frequency>      ! All upstream should be configured
cable upstream <us channel> power-level 0                ! Please work with local RF team to
cable upstream <us channel> channel-width 3200000
no cable upstream <us channel> shutdown
cable upstream <us channel> data-backoff 3 5            ! Default, does not show in configuration.
cable upstream <us channel> connector <physical port number>

```

```

! Unless Virtual Interfaces (VI) are
! configured, the <us channel> and
! <physical port number> should match
cable upstream minislots-size 2
cable upstream <us channel> range-backoff 3 6 ! improves registration times
!
! MC16U/X and MC28U/X Card Configuration
interface cable <interface>/<downstream port>
cable downstream frequency <ds frequency>
cable downstream frequency <ds frequency>
cable downstream rf-power 52
cable downstream rf-shutdown
no cable downstream rf-shutdown
cable upstream <us channel> ingress-noise-cancellation 200 ! default
cable upstream <us channel> channel-width <1st width> <2nd width> ! 1st and 2nd must
! be same value
cable upstream <us channel> modulation-profile <index number> ! see Appendix A
! for new index #s
cable upstream <#> range-backoff 3 6 ! range backoff
cable upstream <us channel> sl60-atp-workaround
!
! OSPF Configuration
router ospf <PID> ! The OSPF PID should match the local
! autonomous system number used for
! BGP
log-adjacency-changes
redistribute rip metric 20 subnets route-map COMM-SVC-NETS |
passive-interface default ! Suppress routing updates on all interfaces
no passive-interface GigabitEthernet0/2 ! Unsuppress routing updates on WAN interface to
establish ospf adjacency
network <network> <wildcard> area 0 ! There should be one net statement
! per connected network
no redistribute static ! Default, does not show in
no redistribute connected ! Default, does not show in
! configuration. Directly connected
! interfaces that are to be
! advertised in OSPF should be
! explicitly configured
neighbor 24.93.33.114 priority 1
!
! BGP Configuration
router bgp <Public AS>
no synchronization
bgp log-neighbor-changes
bgp graceful-restart restart-time 120 ! Nonstop forwarding Awareness
bgp graceful-restart stalepath-time 360
bgp graceful-restart
network <CPE-NETS> mask <MASK>
network <VOIP-NETS> mask <MASK>
network <Residential-AOL> mask <MASK>
network <Residential-Earthlink> mask <MASK>
network <IP NET's needed in BGP> mask <mask>
network <LOCAL-NETS> mask <MASK>
redistribute rip route-map COMM-SVC-NETS
neighbor AGGREGATE-L3-RR-CLIENT peer-group
neighbor AGGREGATE-L3-RR-CLIENT remote-as <Public AS>
neighbor AGGREGATE-L3-RR-CLIENT password <password>
neighbor AGGREGATE-L3-RR-CLIENT update-source Loopback0
neighbor AGGREGATE-L3-RR-CLIENT next-hop-self
neighbor AGGREGATE-L3-RR-CLIENT send-community
neighbor AGGREGATE-L3-RR-CLIENT soft-reconfiguration inbound
neighbor AGGREGATE-L3-RR-CLIENT route-map CMTS-REG out
neighbor <AGG Router #1 IP> peer-group AGGREGATE-L3-RR-CLIENT
neighbor <AGG Router #2 IP> peer-group AGGREGATE-L3-RR-CLIENT
no auto-summary
!
ip bgp-community new-format
!
! RIP Configuration
Router RIP
Version 2

```

```

passive-interface default      | Specify passive for all interfaces. You must configure WAN interfaces
non-passive.
network 10.0.0.0
no network 24.0.0.0           | Public Address Space. Default, |does not show in configuration
distribute-list 40 in
no auto-summary
!
! Route Maps
! Route Maps should be used whenever one set of routing information is redistributed into another set
of
! routing information. Redistribution is currently required for the Static IP solution. Access list
40 is
! used to define the networks which are permitted to be redistributed for Commercial Services.
! Route-Map COMM-SVC-NETS permit 10 | a route map similar to that used | for RIP redistribution
MAY be ! used | for redistribution as long as it | corresponds to an approved ACL
  Match ip address 40
!
route-map COMM-SVC-NETS permit 10
  match ip address 40
  set community DIV:6000
!
route-map CMTS-REG permit 5
  match ip prefix-list <prefix list name>
  set community DIV:4003
route-map CMTS-REG permit 10
  match ip prefix-list <prefix list name>
  set community DIV:5000
route-map CMTS-REG permit 15
  match ip prefix-list <prefix list name>
  set community DIV:5001
route-map CMTS-REG permit 20
  match ip prefix-list <prefix list name>
  set community DIV:4000
route-map CMTS-REG permit 25
  match ip prefix-list <prefix list name>
  set community DIV:3001
route-map CMTS-REG permit 30
  match ip prefix-list <prefix list name>
  set community DIV:4002
route-map CMTS-REG permit 35
  match ip prefix-list <prefix list name>
  set community DIV:4001
route-map CMTS-REG permit 40
  match ip prefix-list <prefix list name>
  set community DIV:4004
route-map CMTS-REG permit 45
  match ip prefix-list <prefix list name>
!
ip prefix-list <prefix list name> seq 5 permit <IP NET>
ip prefix-list <prefix list name> seq 5 permit <IP NET>
ip prefix-list <prefix list name> seq 5 permit <IP NET>
ip prefix-list <prefix list name> seq 5 permit <IP NET>
ip prefix-list <prefix list name> seq 10 permit <IP NET>
ip prefix-list <prefix list name> seq 5 permit <IP NET>
ip prefix-list <prefix list name> seq 10 permit <IP NET>
ip prefix-list <prefix list name> seq 5 permit <IP NET>
ip prefix-list <prefix list name> seq 10 permit <IP NET>
ip prefix-list <prefix list name> seq 5 permit <IP NET>
ip prefix-list <prefix list name> seq 10 permit <IP NET>
ip prefix-list <prefix list name> seq 5 permit <IP NET>
!
! SYSLOG Configuration
logging source-interface Loopback0
logging buffered 512000 ! Set log file size
logging facility local6
logging <primary logging server>
! logging defaults to level 7. Refer |to Monitoring Servers Definition for |Network Devices Deployment
Standard ! for a complete list of poller IP |Address
! logging <secondary logging server> | Refer to Monitoring servers |Definition for Network Devices
! Deployment Standard for a complete |list of syslog collector IP address
logging <local server> ! optional third local logging server

```



```

logging host <ip address>      ! this command may appear after defining a logging server in the step
above
logging monitor warnings      ! this command limits the logging messages that are displayed on
terminal lines -
!                               other then the console line - to messages with a level up to and including
the
!                               specified level argument.
logging trap informational    ! Syslog level
no logging console
cable logging badipsource     ! log "badipsrc" msgs to different log
cable logging layer2events 512000 ! log docsis msgs to different log
!
! Access Control Lists
Access-list compile
access-list 5 permit <ip address> <address mask>      ! ACL 5 is used to limit VTY access to network
devices
access-list 5 permit <local.subnet> <wildcard> ! Local VTY permits
access-list 6 permit <ip address> <address mask>
! This list should not be changed.
! It should be the same on all
! routers in the network
access-list 7 permit <ip address> <wildcard> ! List for Regional SNMP access |(optional)
access-list 8 permit <ip address> <wildcard> ! List for Affiliate SNMP access |(optional)
access-list 15 permit <ip address> <wildcard> | Used for legacy equipment

access-list 40 permit <ip address> <wildcard> ! List for static IP networks
!
! SNMP Configuration
snmp-server engineID local <auto-generated Key> ! Auto generated by router, not configurable
snmp-server contact <contact>
snmp-server location <address>
snmp-server chassis-id <server name>
no snmp-server community public RO
snmp-server community <snmp string> RO 6
snmp-server community <snmp string> RO 7
snmp-server community <Affiliate string> RO 8 ! ACL 8 lists Affiliate hosts
snmp-server trap-source Loopback0
snmp-server host <trap collector> <snmpstring> | needed for each collector
snmp-server ifindex persist | Interface index (ifindex) is retained when router is rebooted.
snmp-server enable traps snmp
snmp-server enable traps config
snmp-server enable traps entity
snmp-server enable traps cable
snmp-server enable traps bgp
snmp-server enable traps pim neighbor-change rp-mapping-change invalid-pim-message
snmp-server enable traps ipmulticast
snmp-server enable traps envmon
snmp-server enable traps rtr
snmp-server enable traps atm pvc
snmp-server enable traps tty ! sometimes default
!
! Message of the Day
banner motd ^
                *****Warning Notice*****
This system is restricted solely to <operator>? authorized users for
<cut>
                ***** Network Operations Center <telephone #> *****
^
!
! Virtual Terminal Lines
Virtual Terminal access
Line console 0
No password ! Default, does not show in
! configuration
exec prompt timestamp ! Gives NTP timestamp when doing CLI
line vty 0 4
exec prompt timestamp ! Gives NTP timestamp when doing CLI
default session-timeout
default exec-timeout
access-class 5 in

```

```

line vty 5 10 | additional vty added to support |multiple access for trouble shooting |and Polling at
the same time
  default session-timeout
  default exec-timeout
  access-class 5 in
!
! Crash Dumps
! As a temporary troubleshooting measure (usually at the request of the vendor), it is approved to
place the
! following command into the configuration:
! exception crashinfo file slot0: | slot0:/disk0: for NPE other then |G1. G1's use disk2:
!
! Packet Cable Multi-Media (PCMM)
access-list 6 permit host <ip address> | grant SNMP RO access from PCMM server
packetcable authorize vanilla-docsis-mta | enable PCMM
packetcable multimedia | enable PCMM
ip access-list extended cops | specify acl to allow access
  permit ip host <VIP1 address of regional MPE> host <ubr's loopback address>
  permit ip host <VIP2 address of regional MPE> host <ubr's loopback address>
cops listener access-list cops | apply the acl to the PCMM process

! Modulation Profile(omitted)
! Channel Width (omitted)
! Modulation Profile in interface example (omitted)
!
! Activating DHCP Relay
! The cable relay agent is for use with DOCSIS-based DHCP servers that use option 82 to automatically
map the
! Ethernet MAC address of a host (end user PC) with the cable modem to which it is connected.
!
! With the cable relay agent activated, the Cisco uBR7200 series will insert the cable modem MAC
address into a
! DHCP packet when a packet is received from a cable modem or another host. The Cisco uBR7200 series
will then
! forward the packet to a DHCP server.
! To activate the cable relay agent on each interface, use the following command global command:
ip dhcp relay information option
!
! Tool Access
ip rcmd rsh-enable
ip rcmd remote-host cmit xx.xx.xx.xx cmit
! CMIT is the name of the remote |client and xx is the ip address |of the unit the client is |accessing
from.
! There could be |multiple entries for each ip |address and client permitted |access.
privilege exec level 1 clear
privilege exec level 1 clear cable
privilege exec level 1 clear cable flap-list
privilege exec level 1 clear cable host
privilege exec level 1 show controller
privilege exec level 1 show cable qos
privilege exec level 1 show cable modem
privilege exec level 1 show cable modem detail
privilege exec level 1 show cable modem verbose
privilege exec level 1 show cable modem offline
privilege exec level 1 show interfaces cable6/0 modem
privilege exec level 1 show interfaces cable6/1 modem
privilege exec level 1 show interfaces cable5/0 modem
privilege exec level 1 show interfaces cable5/1 modem
privilege exec level 1 show interfaces cable4/0 modem
privilege exec level 1 show interfaces cable4/1 modem
privilege exec level 1 show interfaces cable3/0 modem
privilege exec level 1 show interfaces cable3/1 modem
privilege exec level 1 show cable modem 0000.0000.0000 verbose
!
! (CALEA configuration omitted)
! (CBI configuration omitted)
!
! Spectrum Groups (omitted)
!

```

## II.2 CMTS Example Configuration File B

Following is the majority of a complete configuration file for a typical DOCSIS 1.1 CMTS used in production today. When <angle brackets> are used, the actual text in the configuration file varies among operators or was removed to make the configuration generic to all operators. Other comments indicate if other sections were purposefully omitted to keep the example brief and readable.

```
!!!!
!
! DOCSIS 1.1 Example Configuration File B
!
!!!!
!
service nagle
no service pad
service timestamps debug datetime msec show-timezone
service timestamps log datetime msec show-timezone
service password-encryption
!
hostname <hostname>
!
boot-start-marker
boot system disk0:<image name>.bin
boot system disk2:<image2 name>.bin
boot bootldr bootflash:<image3 name>.bin
boot-end-marker
!
logging buffered 512000 debugging
enable secret 5 <secret key>
!
clock timezone EST -5
clock summer-time EDT recurring
fastether transmit store_and_forward enable
no cable admission-control preempt priority-voice
cable flap-list size 8191
cable flap-list power-adjust threshold 3
cable flap-list aging 1440
cable source-verify leasequery-filter downstream 10 5
cable modem max-cpe 10
cable modem vendor 00.<nn>.<nn> VendorNameCM
!
! Modulation profiles (omitted)
!
cable service flow activity-timeout 300
no cable qos permission create
no cable qos permission update
cable qos permission modems
cable logging badipsources 10000
cable logging layer2events 512000
cable time-server
cable dsg client-list 1 id-index 1 mac-addr 0001.a6d0.0b1e
cable dsg client-list 1 id-index 2 ca-system-id E00
cable dsg client-list 2 id-index 1 mac-addr 0001.a6d0.0b01
cable dsg client-list 2 id-index 2 mac-addr 0001.a6d0.0b1e
cable dsg client-list 2 id-index 3 ca-system-id E00
cable dsg client-list 3 id-index 1 application-id 2
cable dsg client-list 11 id-index 1 ca-system-id 700
cable dsg client-list 12 id-index 1 ca-system-id 701
cable dsg client-list 13 id-index 1 application-id 18
cable dsg client-list 14 id-index 1 broadcast 2
cable dsg client-list 99 id-index 1 mac-addr 0001.a6fe.0000
cable dsg client-list 99 id-index 2 ca-system-id E00
cable dsg client-list 100 id-index 1 mac-addr 0001.a6ff.0064
cable dsg client-list 100 id-index 2 ca-system-id E00
cable dsg client-list 101 id-index 1 mac-addr 0001.a6ff.0065
cable dsg client-list 101 id-index 2 ca-system-id E00
cable dsg client-list 102 id-index 1 mac-addr 0001.a6ff.0066
cable dsg client-list 102 id-index 2 ca-system-id E00
cable dsg tg 1 channel 30
cable dsg tg 1 channel 50
cable dsg tg 1 channel 50 ucid 1 2
```

```

cable dsg tg 1 channel 60
cable dsg tg 2 channel 30
cable dsg tg 3 channel 50
cable dsg tg 3 channel 50 ucid 3 4
cable dsg tg 3 channel 60
cable dsg tg 3 channel 60 ucid 2
cable dsg tg 3 channel 61
cable dsg tg 4 channel 50
cable dsg tg 5 channel 60
cable dsg tg 5 channel 61
cable dsg tg 11 channel 30
cable dsg tg 11 channel 51
cable dsg tg 11 channel 60
cable dsg tg 11 channel 61
cable dsg tg 12 channel 30
cable dsg tg 12 channel 51
cable dsg tg 12 channel 51 ucid 1 2
cable dsg tg 12 channel 60
cable dsg tg 12 channel 61
cable dsg tg 13 channel 51
cable dsg tg 13 channel 51 ucid 3 4
cable dsg tg 13 channel 60
cable dsg tg 13 channel 61
cable dsg tg 14 channel 30
cable dsg tg 15 channel 51
cable dsg tg 16 channel 60
cable dsg tg 16 channel 61
cable dsg tg 100 channel 60
cable dsg tg 100 channel 61
cable dsg tg 999 channel 999
cable dsg tunnel 1 mac-addr 1001.0dcd.0001 tg 1 clients 1
cable dsg tunnel 2 mac-addr 1001.0dcd.0002 tg 2 clients 2
cable dsg tunnel 3 mac-addr 1001.0dcd.0003 tg 3 clients 1
cable dsg tunnel 4 mac-addr 1001.0dcd.0004 tg 4 clients 2
cable dsg tunnel 5 mac-addr 1001.0dcd.0005 tg 5 clients 2
cable dsg tunnel 6 mac-addr 1001.0dcd.0030 tg 100 clients 3
cable dsg tunnel 11 mac-addr 1001.0dcd.0011 tg 11 clients 11
cable dsg tunnel 12 mac-addr 1001.0dcd.0012 tg 12 clients 12
cable dsg tunnel 13 mac-addr 1001.0dcd.0013 tg 13 clients 12
cable dsg tunnel 14 mac-addr 1001.0dcd.0014 tg 11 clients 13
cable dsg tunnel 15 mac-addr 1001.0dcd.0015 tg 14 clients 14
cable dsg tunnel 16 mac-addr 1001.0dcd.0016 tg 15 clients 14
cable dsg tunnel 17 mac-addr 1001.0dcd.0017 tg 16 clients 14
cable dsg tunnel 100 mac-addr 0100.5e41.fd64 tg 100 clients 99
cable dsg tunnel 102 mac-addr 0100.5e41.fd66 tg 100 clients 101
cable dsg tunnel 103 mac-addr 0100.5e41.fd67 tg 100 clients 100
cable dsg tunnel 104 mac-addr 0100.5e41.fd68 tg 100 clients 102
cable dsg tunnel 105 mac-addr 0100.5e41.fd69 tg 100 clients 100
cable dsg tunnel 106 mac-addr 0100.5e41.fd6a tg 100 clients 100
cable dsg tunnel 107 mac-addr 0100.5e41.fd6b tg 100 clients 102
cable dsg tunnel 108 mac-addr 0100.5e41.fd6c tg 100 clients 101
cable dsg tunnel 9998 mac-addr 9998.9998.9998 tg 999 clients 14
cable dsg tunnel 9999 mac-addr 9999.9999.9999 tg 999 clients 12
cable dsg cfr 1 dest-ip <ip address> tunnel 1 priority 0 src-ip <ip address> in-dcd yes
cable dsg cfr 2 dest-ip <ip address> tunnel 2 priority 0 src-ip <ip address> in-dcd yes
cable dsg cfr 3 dest-ip <ip address> tunnel 3 priority 0 src-ip <ip address> in-dcd yes
cable dsg cfr 4 dest-ip <ip address> tunnel 4 priority 0 src-ip <ip address> in-dcd yes
cable dsg cfr 5 dest-ip <ip address> tunnel 5 priority 0 src-ip <ip address> in-dcd yes
cable dsg cfr 6 dest-ip <ip address> tunnel 6 priority 1 src-ip <ip address> in-dcd yes
cable dsg cfr 11 dest-ip <ip address> tunnel 11 priority 0 src-ip <ip address> in-dcd yes
cable dsg cfr 12 dest-ip <ip address> tunnel 12 priority 0 src-ip <ip address> in-dcd yes
cable dsg cfr 13 dest-ip <ip address> tunnel 13 priority 0 src-ip <ip address> in-dcd yes
cable dsg cfr 14 dest-ip <ip address> tunnel 14 priority 0 src-ip <ip address> in-dcd yes
cable dsg cfr 15 dest-ip <ip address> tunnel 15 priority 0 src-ip <ip address> in-dcd yes
cable dsg cfr 16 dest-ip <ip address> tunnel 16 priority 0 src-ip <ip address> in-dcd yes
cable dsg cfr 17 dest-ip <ip address> tunnel 17 priority 0 src-ip <ip address> in-dcd yes
cable dsg cfr 100 dest-ip <ip address> tunnel 100 priority 0 src-ip <ip address> in-dcd yes
cable dsg cfr 102 dest-ip <ip address> tunnel 102 priority 0 src-ip <ip address> in-dcd yes
cable dsg cfr 103 dest-ip <ip address> tunnel 103 priority 0 src-ip <ip address> in-dcd yes
cable dsg cfr 104 dest-ip <ip address> tunnel 104 priority 0 src-ip <ip address> in-dcd yes
cable dsg cfr 105 dest-ip <ip address> tunnel 105 priority 0 src-ip <ip address> in-dcd yes
cable dsg cfr 106 dest-ip <ip address> tunnel 106 priority 0 src-ip <ip address> in-dcd yes

```

```

cable dsg cfr 107 dest-ip <ip address> tunnel 107 priority 0 src-ip <ip address> in-dcd yes
cable dsg cfr 108 dest-ip <ip address> tunnel 108 priority 0 src-ip <ip address> in-dcd yes
cable dsg cfr 9998 dest-ip <ip address> tunnel 9998 priority 0 src-ip <ip address> in-dcd yes
cable dsg cfr 9999 dest-ip <ip address> tunnel 9999 priority 0 src-ip <ip address> in-dcd yes
cable dsg timer 1 Tdsg1 2 Tdsg2 60 Tdsg3 30 Tdsg4 180
cable load-balance group 1
cable load-balance group 2 method utilization
cable load-balance group 2 threshold load 10 enforce 20
cable load-balance group 3 method utilization
cable load-balance group 3 threshold load 10 enforce 20
cable load-balance group 5 method utilization
cable load-balance group 5 dcc-init-technique 4
cable load-balance group 5 threshold load 10 enforce 20
cable load-balance group 6 method utilization
cable load-balance group 6 dcc-init-technique 4
cable load-balance group 6 threshold load 10 enforce 20
cable load-balance group 6 policy us-groups-across-ds
!
cable config-file ADSG-staging
  service-class 1 max-upstream 2000
  service-class 1 max-downstream 10000
  service-class 1 max-burst 1600
  cpe max 2
!
aaa new-model
!
!
aaa authentication login default group tacacs+ enable
aaa authentication enable default enable
aaa authorization config-commands
aaa authorization exec default group tacacs+ none
aaa authorization commands 15 default group tacacs+ none
aaa accounting exec default start-stop group tacacs+
aaa accounting commands 1 default start-stop group tacacs+
aaa accounting commands 15 default start-stop group tacacs+
aaa accounting network default start-stop group tacacs+
aaa accounting system default start-stop group tacacs+
aaa session-id common
ip subnet-zero
no ip source-route
no ip gratuitous-arps
!
!
ip cef
ip tftp source-interface Loopback0
ip domain name <domain name>.<sub-domain>.com
ip host riverstone <ip address>
ip name-server <ip address>
ip name-server <ip address>
ip name-server <ip address>
ip dhcp relay information option
!
ip dhcp pool ADSG-eCM
  network <ip address> <netmask>
  bootfile ADSG-staging.bin
  next-server <ip address>
  default-router <ip address>
  option 2 hex ffff.aaaa
  option 4 ip <ip address>
  option 7 ip <ip address>
!
ip dhcp pool ADSG-host
  network <ip address> <netmask>
  default-router <ip address>
!
no ip bootp server
ip multicast-routing
ip multicast route-limit 250
ip igmp limit 500
ip igmp ssm-map enable
no ip igmp ssm-map query dns
ip igmp ssm-map static VLC3 <ip address>

```

```

ip igmp ssm-map static groups1 <ip address>
ip igmp ssm-map static VLC1 <ip address>
ip igmp ssm-map static VLC2 <ip address>
packetcable authorize <list name>
packetcable multimedia
!
! Certificate Entry
!
crypto ca trustpoint DOCSIS-ROOT-CERT
!
crypto ca trustpoint CN==<vendor name>,-OU==<vendor address>,-OU-
==DOCSIS,-O==<short vendor name>,-C==US
! followed by other vendor certificates
!
crypto ca trustpoint ffffffffffffffffffffffffffffffffffffffffff
!
crypto ca certificate chain DOCSIS-ROOT-CERT
certificate ca ffffffffffffffffffffffffffffffffffffffffff
ffffffff ffffffff ffffffff ffffffff ffffffff ffffffff ffffffff ffffffff
ffffffff ffffffff ffffffff ffffffff ffffffff ffffffff ffffffff ffffffff
ffffffff ffffffff ffffffff ffffffff ffffffff ffffffff ffffffff ffffffff
ffffffff ffffffff ffffffff ffffffff ffffffff ffffffff ffffffff ffffffff
ffffffff ffffffff ffffffff ffffffff ffffffff ffffffff ffffffff ffffffff
ffffffff ffffffff ffffffff ffffffff ffffffff ffffffff ffffffff ffffffff
ffffffff ffffffff ffffffff ffffffff ffffffff ffffffff ffffffff ffffffff
ffffffff ffffffff ffffffff ffffffff ffffffff ffffffff ffffffff ffffffff
ffffffff ffffffff ffffffff ffffffff ffffffff ffffffff ffffffff ffffffff
ffffffff ffffffff ffffffff ffffffff ffffffff ffffffff ffffffff ffffffff
ffffffff ffffffff ffffffff ffffffff ffffffff ffffffff ffffffff ffffffff
ffffffff ffffffff ffffffff ffffffff ffffffff ffffffff ffffffff ffffffff
ffffffff ffffffff ffffffff ffffffff ffffffff ffffffff ffffffff ffffffff
ffffffff ffffffff ffffffff ffffffff ffffffff ffffffff ffffffff ffffffff
ffffffff ffffffff ffffffff ffffffff ffffffff ffffffff ffffffff ffffffff
ffffffff ffffffff ffffffff ffffffff ffffffff ffffffff ffffffff ffffffff
ffffffff ffffffff ffffffff ffffffff ffffffff ffffffff ffffffff ffffffff
ffffffff ffffffff ffffffff ffffffff ffffffff ffffffff ffffffff ffffffff
ffffffff ffffffff ffffffff ffffffff ffffffff ffffffff ffffffff ffffffff
ffffffff ffffffff ffffffff ffffffff ffffffff ffffffff ffffffff ffffffff
ffffffff ffffffff ffffffff ffffffff ffffffff ffffffff ffffffff ffffffff
quit
!
! followed by additional certificates
!
key chain ubr-rip
key 1
key-string 7 000000000000
key 2
key-string 7 000000000000
!
buffers small permanent 310
buffers small max-free 515
buffers small min-free 65
buffers middle permanent 258
buffers middle max-free 360
buffers middle min-free 80
buffers big permanent 528
buffers big max-free 828
buffers big min-free 180
buffers verybig permanent 42
buffers verybig max-free 43
buffers verybig min-free 6
!

```

```
interface Loopback0
  description <loopback interface description>
  ip address <ip address> <netmask>
  no ip redirects
  no ip proxy-arp
  no ip mroute-cache
  no keepalive
!
interface FastEthernet0/0
  no ip address
  no ip redirects
  no ip proxy-arp
  load-interval 30
  shutdown
  duplex full
!
interface GigabitEthernet0/1
  no ip address
  shutdown
  duplex auto
  speed auto
  media-type rj45
  negotiation auto
!
interface GigabitEthernet0/2
  no ip address
  shutdown
  duplex auto
  speed auto
  media-type rj45
  negotiation auto
!
interface GigabitEthernet0/3
  no ip address
  shutdown
  duplex auto
  speed auto
  media-type rj45
  negotiation auto
!
interface Cable3/0
  description SPECIAL CLIENT AREA INTERFACE
  no ip address
  load-interval 30
  cable shared-secret 7 00000000000000000000
  cable enable-trap cmonoff-notification
  cable enable-trap cmonoff-interval 600
  no cable packet-cache
  cable bundle 99
  cable downstream rate-limit
  cable downstream annex B
  cable downstream modulation 256qam
  cable downstream interleave-depth 32
  cable downstream frequency 603000000
  cable downstream channel-id 30
  cable downstream description SA + Moto non-straddled
  cable downstream dsg tg 1 channel 30
  cable downstream dsg tg 2 channel 30
  cable downstream dsg tg 11 channel 30
  cable downstream dsg tg 12 channel 30
  cable downstream dsg tg 14 channel 30
  cable upstream 0 description CLIENT AREA
  cable upstream 0 frequency 33008000
  cable upstream 0 channel-width 3200000
  cable upstream 0 minislots-size 2
  cable upstream 0 power-level 0
  cable upstream 0 range-backoff 3 6
  cable upstream 0 modulation-profile 9
  cable upstream 0 load-balance group 2
  no cable upstream 0 shutdown
  cable upstream 1 description CLIENT AREA
  cable upstream 1 frequency 20704000
```

```

cable upstream 1 channel-width 3200000
cable upstream 1 minislots-size 2
cable upstream 1 power-level 0
cable upstream 1 range-backoff 3 6
cable upstream 1 modulation-profile 9
cable upstream 1 load-balance group 2
no cable upstream 1 shutdown
cable upstream 2 frequency 33008000
cable upstream 2 channel-width 3200000
cable upstream 2 minislots-size 2
cable upstream 2 power-level 0
cable upstream 2 range-backoff 3 6
cable upstream 2 modulation-profile 9
no cable upstream 2 shutdown
cable upstream 3 frequency 33008000
cable upstream 3 channel-width 3200000
cable upstream 3 minislots-size 2
cable upstream 3 power-level 0
cable upstream 3 range-backoff 3 6
cable upstream 3 modulation-profile 9
no cable upstream 3 shutdown
cable upstream 4 frequency 33008000
cable upstream 4 channel-width 3200000
cable upstream 4 minislots-size 4
cable upstream 4 power-level 0
cable upstream 4 range-backoff 3 6
cable upstream 4 modulation-profile 8
no cable upstream 4 shutdown
cable upstream 5 frequency 33008000
cable upstream 5 channel-width 3200000
cable upstream 5 minislots-size 4
cable upstream 5 power-level 0
cable upstream 5 range-backoff 3 6
cable upstream 5 modulation-profile 8
no cable upstream 5 shutdown
no keepalive
!
interface Cable4/0
description SPECIAL CLIENT AREA INTERFACE
no ip address
cable shared-secret 7 00000000000000000000
cable enable-trap cmonoff-notification
cable enable-trap cmonoff-interval 600
no cable packet-cache
cable bundle 99
cable downstream annex B
cable downstream modulation 256qam
cable downstream interleave-depth 32
cable downstream frequency 615000000
cable downstream channel-id 40
no cable downstream rf-shutdown
cable upstream 0 description CLIENT AREA
cable upstream 0 connector 0
cable upstream 0 frequency 10000000
cable upstream 0 ingress-noise-cancellation 200
cable upstream 0 docsis-mode tdma-atdma
cable upstream 0 channel-width 3200000 3200000
cable upstream 0 minislots-size 2
cable upstream 0 range-backoff 3 6
cable upstream 0 modulation-profile 143
cable upstream 0 load-balance group 2
no cable upstream 0 shutdown
cable upstream 1 description CLIENT AREA
cable upstream 1 connector 1
cable upstream 1 frequency 14000000
cable upstream 1 ingress-noise-cancellation 200
cable upstream 1 docsis-mode tdma-atdma
cable upstream 1 channel-width 3200000 3200000
cable upstream 1 minislots-size 2
cable upstream 1 range-backoff 3 6
cable upstream 1 modulation-profile 143
cable upstream 1 load-balance group 2

```



```
no cable upstream 1 shutdown
cable upstream 2 connector 2
cable upstream 2 frequency 22000000
cable upstream 2 ingress-noise-cancellation 200
cable upstream 2 docsis-mode tdma-atdma
cable upstream 2 channel-width 3200000 3200000
cable upstream 2 minislot-size 2
cable upstream 2 range-backoff 3 6
cable upstream 2 modulation-profile 143
cable upstream 2 load-balance group 3
cable upstream 2 shutdown
cable upstream 3 connector 3
cable upstream 3 frequency 18000000
cable upstream 3 ingress-noise-cancellation 200
cable upstream 3 docsis-mode tdma-atdma
cable upstream 3 channel-width 3200000 3200000
cable upstream 3 minislot-size 2
cable upstream 3 range-backoff 3 6
cable upstream 3 modulation-profile 143
cable upstream 3 load-balance group 3
cable upstream 3 shutdown
!
interface Cable4/1
description SPECIAL CLIENT AREA INTERFACE
no ip address
shutdown
cable shared-secret 7 00000000000000000000
cable enable-trap cmonoff-notification
cable enable-trap cmonoff-interval 600
no cable packet-cache
cable bundle 99
cable downstream annex B
cable downstream modulation 256qam
cable downstream interleave-depth 32
cable downstream frequency 603000000
cable downstream channel-id 41
no cable downstream rf-shutdown
cable upstream 0 connector 4
cable upstream 0 frequency 26000000
cable upstream 0 ingress-noise-cancellation 200
cable upstream 0 docsis-mode tdma-atdma
cable upstream 0 channel-width 3200000 3200000
cable upstream 0 minislot-size 2
cable upstream 0 range-backoff 3 6
cable upstream 0 modulation-profile 143
cable upstream 0 load-balance group 2
no cable upstream 0 shutdown
cable upstream 1 connector 5
cable upstream 1 frequency 30000000
cable upstream 1 ingress-noise-cancellation 200
cable upstream 1 docsis-mode tdma-atdma
cable upstream 1 channel-width 3200000 3200000
cable upstream 1 minislot-size 2
cable upstream 1 range-backoff 3 6
cable upstream 1 modulation-profile 143
cable upstream 1 load-balance group 2
no cable upstream 1 shutdown
cable upstream 2 connector 6
cable upstream 2 frequency 34000000
cable upstream 2 ingress-noise-cancellation 200
cable upstream 2 docsis-mode tdma-atdma
cable upstream 2 channel-width 3200000 3200000
cable upstream 2 minislot-size 2
cable upstream 2 range-backoff 3 6
cable upstream 2 modulation-profile 143
cable upstream 2 load-balance group 3
cable upstream 2 shutdown
cable upstream 3 connector 7
cable upstream 3 frequency 38000000
cable upstream 3 ingress-noise-cancellation 200
cable upstream 3 docsis-mode tdma-atdma
cable upstream 3 channel-width 3200000 3200000
```

```

cable upstream 3 minislot-size 2
cable upstream 3 range-backoff 3 6
cable upstream 3 modulation-profile 143
cable upstream 3 load-balance group 3
cable upstream 3 shutdown
!
interface Cable5/0
description STANDARD PURPOSE INTERFACE
no ip address
cable shared-secret 7 00000000000000000000
cable enable-trap cmonoff-notification
cable enable-trap cmonoff-interval 600
no cable packet-cache
cable bundle 1
cable downstream rate-limit
cable downstream annex B
cable downstream modulation 256qam
cable downstream interleave-depth 32
cable downstream frequency 603000000
cable downstream channel-id 50
cable downstream description SA straddled
cable downstream dsd tg 1 channel 50
cable downstream dsd tg 3 channel 50
cable downstream dsd tg 4 channel 50
no cable downstream rf-shutdown
cable upstream 0 connector 0 shared
cable upstream 0 frequency 10000000
cable upstream 0 ingress-noise-cancellation 200
cable upstream 0 channel-width 3200000 3200000
cable upstream 0 minislot-size 2
cable upstream 0 range-backoff 3 6
cable upstream 0 modulation-profile 49
cable upstream 0 load-balance group 2
cable upstream 0 shutdown
cable upstream 1 connector 0 shared
cable upstream 1 frequency 14000000
cable upstream 1 ingress-noise-cancellation 200
cable upstream 1 channel-width 3200000 3200000
cable upstream 1 minislot-size 2
cable upstream 1 range-backoff 3 6
cable upstream 1 modulation-profile 49
cable upstream 1 load-balance group 2
no cable upstream 1 shutdown
cable upstream 2 connector 2 shared
cable upstream 2 frequency 22000000
cable upstream 2 ingress-noise-cancellation 200
cable upstream 2 channel-width 3200000 3200000
cable upstream 2 minislot-size 2
cable upstream 2 range-backoff 3 6
cable upstream 2 modulation-profile 49
cable upstream 2 load-balance group 2
cable upstream 2 shutdown
cable upstream 3 connector 2 shared
cable upstream 3 frequency 18000000
cable upstream 3 ingress-noise-cancellation 200
cable upstream 3 channel-width 3200000 3200000
cable upstream 3 minislot-size 2
cable upstream 3 range-backoff 3 6
cable upstream 3 modulation-profile 49
cable upstream 3 load-balance group 2
no cable upstream 3 shutdown
!
interface Cable5/1
description STANDARD PURPOSE INTERFACE
no ip address
cable shared-secret 7 00000000000000000000
cable enable-trap cmonoff-notification
cable enable-trap cmonoff-interval 600
no cable packet-cache
cable bundle 1
cable downstream rate-limit
cable downstream annex B

```

```

cable downstream modulation 256qam
cable downstream interleave-depth 32
cable downstream frequency 615000000
cable downstream channel-id 51
cable downstream description Moto straddled
cable downstream dsg tg 11 channel 51
cable downstream dsg tg 12 channel 51
cable downstream dsg tg 13 channel 51
cable downstream dsg tg 15 channel 51
no cable downstream rf-shutdown
cable upstream 0 connector 4 shared
cable upstream 0 frequency 26000000
cable upstream 0 ingress-noise-cancellation 200
cable upstream 0 channel-width 3200000 3200000
cable upstream 0 minislot-size 2
cable upstream 0 range-backoff 3 6
cable upstream 0 modulation-profile 49
cable upstream 0 load-balance group 3
no cable upstream 0 shutdown
cable upstream 1 connector 4 shared
cable upstream 1 frequency 30000000
cable upstream 1 ingress-noise-cancellation 200
cable upstream 1 channel-width 3200000 3200000
cable upstream 1 minislot-size 2
cable upstream 1 range-backoff 3 6
cable upstream 1 modulation-profile 49
cable upstream 1 load-balance group 3
no cable upstream 1 shutdown
cable upstream 2 connector 6 shared
cable upstream 2 frequency 34000000
cable upstream 2 ingress-noise-cancellation 200
cable upstream 2 channel-width 3200000 3200000
cable upstream 2 minislot-size 2
cable upstream 2 range-backoff 3 6
cable upstream 2 modulation-profile 49
cable upstream 2 load-balance group 3
cable upstream 2 shutdown
cable upstream 3 connector 6 shared
cable upstream 3 frequency 38000000
cable upstream 3 ingress-noise-cancellation 200
cable upstream 3 channel-width 3200000 3200000
cable upstream 3 minislot-size 2
cable upstream 3 range-backoff 3 6
cable upstream 3 modulation-profile 49
cable upstream 3 load-balance group 3
cable upstream 3 shutdown
!
interface Cable6/0
description P.ARNTS TEST
no ip address
cable enable-trap cmonoff-notification
cable enable-trap cmonoff-interval 600
no cable packet-cache
cable bundle 1
cable downstream rate-limit
cable downstream annex B
cable downstream modulation 256qam
cable downstream interleave-depth 32
cable downstream frequency 603000000
cable downstream channel-id 60
cable downstream description SA + Moto non-straddled
cable downstream dsg timer 1
cable downstream dsg tg 11 channel 60
cable downstream dsg tg 12 channel 60
cable downstream dsg tg 16 channel 60
cable downstream dsg tg 100 channel 60
no cable downstream rf-shutdown
cable upstream 0 description P.ARNTS TEST
cable upstream 0 connector 0 shared
cable upstream 0 frequency 10000000
cable upstream 0 ingress-noise-cancellation 200
cable upstream 0 channel-width 3200000 3200000

```

```

cable upstream 0 minislot-size 2
cable upstream 0 power-level 15
cable upstream 0 range-backoff 3 6
cable upstream 0 modulation-profile 41
cable upstream 0 load-balance group 2
no cable upstream 0 shutdown
cable upstream 1 description P.ARNTS TEST
cable upstream 1 connector 0 shared
cable upstream 1 frequency 14000000
cable upstream 1 ingress-noise-cancellation 200
cable upstream 1 channel-width 3200000 3200000
cable upstream 1 minislot-size 2
cable upstream 1 power-level 15
cable upstream 1 range-backoff 3 6
cable upstream 1 modulation-profile 41
cable upstream 1 load-balance group 2
no cable upstream 1 shutdown
cable upstream 2 connector 2
cable upstream 2 frequency 18000000
cable upstream 2 ingress-noise-cancellation 200
cable upstream 2 channel-width 3200000 3200000
cable upstream 2 minislot-size 2
cable upstream 2 power-level 15
cable upstream 2 range-backoff 3 6
cable upstream 2 modulation-profile 41
cable upstream 2 load-balance group 3
no cable upstream 2 shutdown
cable upstream 3 connector 3
cable upstream 3 frequency 22000000
cable upstream 3 ingress-noise-cancellation 200
cable upstream 3 channel-width 3200000 3200000
cable upstream 3 minislot-size 2
cable upstream 3 power-level 15
cable upstream 3 range-backoff 3 6
cable upstream 3 modulation-profile 41
cable upstream 3 load-balance group 3
no cable upstream 3 shutdown
cable privacy accept-self-signed-certificate
cable load-balance group 1
!
interface Cable6/1
description MC28U
no ip address
cable shared-secret 7 00000000000000000000
cable enable-trap cmonoff-notification
cable enable-trap cmonoff-interval 600
no cable packet-cache
cable bundle 1
cable downstream rate-limit
cable downstream annex B
cable downstream modulation 256qam
cable downstream interleave-depth 32
cable downstream frequency 609000000
cable downstream channel-id 61
cable downstream description SA + Moto non-straddled
cable downstream dsg timer 1
cable downstream dsg tg 11 channel 61
cable downstream dsg tg 12 channel 61
cable downstream dsg tg 16 channel 61
cable downstream dsg tg 100 channel 61
no cable downstream rf-shutdown
cable upstream 0 connector 4
cable upstream 0 frequency 26000000
cable upstream 0 ingress-noise-cancellation 200
cable upstream 0 channel-width 3200000 3200000
cable upstream 0 minislot-size 2
cable upstream 0 range-backoff 3 6
cable upstream 0 modulation-profile 41
cable upstream 0 load-balance group 2
no cable upstream 0 shutdown
cable upstream 1 connector 5
cable upstream 1 frequency 30000000

```



```

interface Bundle99
description SPECIAL CLIENT AREA BUNDLE
ip address <ip address> <netmask> secondary
ip address <ip address> <netmask> secondary
ip address <ip address> <netmask>
ip access-group 157 in
ip verify unicast reverse-path allow-self-ping
ip rip authentication mode md5
ip rip authentication key-chain ubr-rip
ip pim sparse-mode
ip igmp static-group <group ip> source <ip address>
ip igmp static-group <group ip> source <ip address>
ip igmp static-group <group ip> source <ip address>
ip igmp static-group <group ip> source <ip address>
ip igmp static-group <group ip> source <ip address>
ip igmp static-group <group ip> source <ip address>
cable arp filter request-send 4 2
cable arp filter reply-accept 4 2
no cable ip-multicast-echo
cable dhcp-giaddr primary
cable helper-address <ip address>
cable helper-address <ip address>
!
router ospf <ospf id>
router-id <ip address>
log-adjacency-changes
passive-interface default
no passive-interface SRP1/0
network <network> <bit mask> area 1
network <network> <bit mask> area 1
network <network> <bit mask> area 1
network <network> <bit mask> area 1
network <network> <bit mask> area 1
network <network> <bit mask> area 1
network <network> <bit mask> area 1
network <network> <bit mask> area 1
network <network> <bit mask> area 1
!
router rip
version 2
passive-interface default
network 10.0.0.0
distribute-list 40 in
no auto-summary
!
router bgp <asn>
no synchronization
bgp log-neighbor-changes
bgp graceful-restart restart-time 120
bgp graceful-restart stalepath-time 360
bgp graceful-restart
network <ip address> mask <netmask>
network <ip address> mask <netmask>
network <ip address> mask <netmask>
network <ip address> mask <netmask>
redistribute rip route-map COMM-SVC-NETS
neighbor RR-client peer-group
neighbor RR-client remote-as <asn>
neighbor RR-client update-source Loopback0
neighbor RR-client next-hop-self
neighbor RR-client send-community
neighbor RR-client soft-reconfiguration inbound
neighbor RR-client route-map CMTS-REG out
neighbor <ip address>peer-group RR-client
neighbor <ip address>peer-group RR-client
no auto-summary
!
ip classless
ip route <ip address> <network mask> FastEthernet0/0
no ip http server
no ip http secure-server
ip tacacs source-interface Loopback0

```

```
!  
ip pim rp-address <ip address>div-multicast  
ip pim ssm range SSM-ALLOW-SRV  
!  
ip prefix-list <list name> seq 5 permit <ip network>/<short mask>  
ip prefix-list <list name> seq 10 permit <ip network>/<short mask>  
!  
ip prefix-list VOIP-NETS seq 5 permit <ip network>/<short mask>  
ip prefix-list VOIP-NETS seq 10 permit <ip network>/<short mask>  
!  
ip access-list standard SSM-ALLOW-SRV  
  permit <ip network><ip network mask>  
  permit <ip network><ip network mask>  
  permit <ip network><ip network mask>  
ip access-list standard VLC1  
  permit <ip address>  
  permit <ip address>  
  permit <ip address>  
ip access-list standard VLC2  
  permit <ip address>  
  permit <ip address>  
  permit <ip address>  
ip access-list standard VLC3  
  permit <ip address>  
  permit <ip address>  
  permit <ip address>  
  permit <ip address>  
  permit <ip address>  
  permit <ip address>  
  permit <ip address>  
  permit <ip address>  
  permit <ip address>  
  permit <ip address>  
ip access-list standard div-multicast  
  permit <ip network> <ip network mask>  
  permit <ip network><ip network mask>  
ip access-list standard groups1  
  permit <ip address>  
  permit <ip address>  
ip access-list standard groups2  
  permit <ip address>  
!  
ip access-list extended cops  
  permit ip host <ip address> host <ip address>  
  permit ip host <ip address> host <ip address>  
  permit ip host <ip address> host <ip address>  
  permit ip host <ip address> host <ip address>  
  permit ip host <ip address> host <ip address>  
  permit ip host <ip address> host <ip address>  
  permit ip host <ip address> host <ip address>  
  permit ip host <ip address> host <ip address>  
ip access-list extended list1  
  permit ip any host <ip address>  
  permit ip any host <ip address>  
  permit ip any host <ip address>  
  permit ip any host <ip address>  
  permit ip any host <ip address>  
ip access-list extended list2  
  permit ip any host <ip address>  
  permit ip any host <ip address>  
  permit ip any host <ip address>  
  permit ip any host <ip address>  
  permit ip any host <ip address>  
ip access-list extended list3  
  permit ip any host <ip address>  
  permit ip any host <ip address>  
  permit ip any host <ip address>  
  permit ip any host <ip address>  
  permit ip any host <ip address>  
ip access-list extended list4  
  permit ip any host <ip address>  
  permit ip any host <ip address>
```

```

permit ip any host <ip address>
permit ip any host <ip address>
permit ip any host <ip address>
logging facility local6
logging source-interface Loopback0
logging <ip address>
logging <ip address>
logging <ip address>
logging <ip address>
access-list 5 permit <ip network> <ip network mask> log
access-list 5 permit <ip network> <ip network mask> log
access-list 5 permit <ip network> <ip network mask> log
access-list 5 permit <ip network> <ip network mask> log
access-list 5 permit <ip network> <ip network mask> log
access-list 5 permit <ip network> <ip network mask> log
access-list 6 permit <ip address>
access-list 6 permit <ip address>
access-list 6 permit <ip address>
access-list 6 permit <ip address>
access-list 6 permit <ip network> <ip network mask>
access-list 6 permit <ip network> <ip network mask>
access-list 6 permit <ip network> <ip network mask>
access-list 6 permit <ip network> <ip network mask>
access-list 6 permit <ip network> <ip network mask>
access-list 7 permit <ip network> <ip network mask>
access-list 7 permit <ip network> <ip network mask>
access-list 7 permit <ip network> <ip network mask>
access-list 7 permit <ip network> <ip network mask>
access-list 8 permit <ip network> <ip network mask>
access-list 20 permit <ip network> <ip network mask>
access-list 20 permit <ip network> <ip network mask>
access-list 20 permit <ip network> <ip network mask>
access-list 20 permit <ip network> <ip network mask>
access-list 20 permit <ip network> <ip network mask>
access-list 20 permit <ip network> <ip network mask>
access-list 20 permit <ip network> <ip network mask>
access-list 40 permit <ip network> <ip network mask>
access-list 40 permit <ip network> <ip network mask>
access-list 157 permit udp any eq rip any eq rip
access-list 157 permit igmp any <ip network> <ip network mask>
access-list 157 permit igmp any <ip network> <ip network mask>
access-list 157 permit igmp any <ip network> <ip network mask>
access-list 157 permit udp any host <ip address>
access-list 157 deny igmp any any
access-list 157 deny icmp any <ip network> <ip network mask>
access-list 157 deny tcp any <ip network> <ip network mask>
access-list 157 deny udp any <ip network> <ip network mask>
access-list 157 permit ip any any
access-list 160 permit ip <ip network> <ip network mask> any
access-list 160 permit ip <ip network> <ip network mask> any
access-list 160 permit udp any any range bootps bootpc
access-list 160 deny ip any any log
!
nls resp-timeout 1
cpd cr-id 1
!
route-map COMM-SVC-NETS permit 10
  match ip address 40
!
route-map CMTS-REG permit 10
  match ip address prefix-list <list name>
!
route-map CMTS-REG permit 20
  match ip address prefix-list <list name>
!
route-map CMTS-REG permit 30
  match ip address 40
!
snmp-server engineID local 000000000000000000000000
snmp-server community <string name> RO
snmp-server community <string name>RO 6
snmp-server community <string name>RO

```



```

snmp-server trap-source Loopback0
snmp-server location <address or description>
snmp-server contact <first name> <last name> <tel #>
snmp-server chassis-id <id>
snmp-server enable traps snmp authentication linkdown linkup coldstart warmstart
snmp-server enable traps atm pvc
snmp-server enable traps config
snmp-server enable traps entity
snmp-server enable traps envmon
snmp-server enable traps rtr
snmp-server host <ip address> <hostname or description>
snmp-server host <ip address> <hostname or description>
snmp-server host <ip address> <hostname or description>
snmp-server host <ip address> <hostname or description>
snmp-server host <ip address> <hostname or description>
snmp-server host <ip address> <hostname or description>
snmp-server manager
tftp-server disk2:<image name>.bin
tacacs-server host <ip address>
tacacs-server host <ip address>
tacacs-server directed-request
tacacs-server key 7 <key>
!
cops listener access-list cops
banner motd ^CCCCC
                *****Warning Notice*****
This system is restricted solely to <operator> authorized users for
<>
                ***** Network Operations Center <> *****
^C
alias exec scm show cable modem
alias exec sci show interface cable
alias exec scr show int cable 3/0 | in rate
alias exec scr4 show int cable 4/0 | in rate
alias exec scr5 show int cable 5/0 | in rate
alias exec scr6 show int cable 6/0 | in rate
alias exec shost show int cable 3/0 modem 0 | in host
alias exec shost3 show int cable 3/0 modem 0 | in host
alias exec shost4 show int cable 4/0 modem 0 | in host
alias exec shost5 show int cable 5/0 modem 0 | in host
alias exec shost6 show int cable 6/0 modem 0 | in host
alias exec sh% show proc cpu | ex 0.00
alias exec scmt show cable modem sum total
alias exec ccm clear cable modem
alias exec scmq show cable modem remote-query
alias exec scf show cable flap-list
alias exec sclb show cable load-balance all
privilege exec level 1 show ip interface brief
privilege exec level 1 show ip interface
privilege exec level 1 show ip
privilege exec level 1 show cable flap-list
privilege exec level 1 show cable modem
privilege exec level 1 show cable qos profile
privilege exec level 15 show cable qos
privilege exec level 1 show cable
privilege exec level 1 show controllers
privilege exec level 1 show interfaces
privilege exec level 1 show running-config
privilege exec level 1 show
privilege exec level 15 clear cable host
privilege exec level 15 clear cable flap-list all
privilege exec level 15 clear cable flap-list
privilege exec level 15 clear cable
privilege exec level 15 clear
!
line con 0
  exec-timeout 30 0
  logging synchronous
  transport preferred telnet
  transport output telnet
  stopbits 1
line aux 0

```

```
transport preferred none
transport output none
stopbits 1
line vty 0 4
access-class 5 in
exec-timeout 60 0
password 7 000000000000
exec prompt timestamp
transport preferred telnet
transport input all
transport output all
line vty 5 15
access-class 5 in
exec-timeout 30 0
password 7 000000000000
exec prompt timestamp
transport preferred telnet
transport input telnet
transport output telnet
!
exception crashinfo file disk0:crashinfo
scheduler allocate 3999 400
ntp clock-period 17179904
ntp source Loopback0
ntp update-calendar
ntp server <ip address>
ntp server <ip address>
ntp peer <ip address>
end
```

## Appendix III Example of IS-IS Configuration (Informative)

Following are examples of additional commands used to configure IS-IS in a CMTS configuration. When <angle brackets> are used, the actual text in the configuration file varies among operators or was removed to make the configuration generic to all operators.

```

!!!!
!
! IS-IS Example Configuration
!
!!!!
!
! Sample Configuration IPv6 IS-IS
!
!
! To enable the forwarding of IPv6 unicast datagrams
ipv6 unicast-routing
! IPv6 Interface Configuration
!
!Loopback interface configuration
  interface Loopback0
    ipv6 address <X:X:X:X::X>/128
    ipv6 enable
!
! Interface connecting to hub equipment (such as 10720)
  interface GigabitEthernet x/x
    ipv6 enable
!
! Loopback interface configuration
!
  interface Loopback0
    ipv6 router IS-IS
!
! Interface connecting to hub equipment (such as CMTS)
!
  interface GigabitEthernet x/x
    ipv6 router IS-IS
    IS-IS network point-to-point
    IS-IS hello-interval 1 level-1
    IS-IS hello-multiplier 3 level-1 ! by default, it won't show here
!
! IPv6 IS-IS Global Configuration
! Configuration example for IS-IS instance level-1
!
router IS-IS
  net <network-entity-title>
  is-type level-1
  metric-style wide ! build the IS-IS route table using the traffic engineering wide 24-bit
metric style
!
  address-family ipv6
  multi-topology
  exit-address-family

```

## Appendix IV DPoE Example Configuration File (Informative)

Following is an example of a configuration for a DPoE System. When <angle brackets> are used, the actual text in the configuration file varies among operators or was removed to make the configuration generic to all operators.

```

!!!!
!
! DPoE Example Configuration File
!
! This is the same as a DOCSIS configuration with RF parameters and some DOCSIS parameters
removed and
! with DPoE parameters added.
!
!!!!
!
service timestamps debug datetime msec show-timezone
service timestamps log datetime msec show-timezone
service password-encryption
!
hostname dpoe-sys1
!
boot-start-marker
boot system disk0:<image name>.bin
boot system disk2:<image2 name>.bin
boot bootldr bootflash:<image3 name>.bin
boot-end-marker
!
logging buffered 512000 debugging
enable secret 5 <secret key>
!
clock timezone EST -5
clock summer-time EDT recurring
fastether transmit store_and_forward enable
no cable admission-control preempt priority-voice
cable flap-list size 8191
cable flap-list power-adjust threshold 3
cable flap-list aging 1440
cable source-verify leasequery-filter downstream 10 5
cable modem max-cpe 10
cable modem vendor 00.<nn>.<nn> DPoE-ONU-Vendor-A
!
cable service flow activity-timeout 300
no cable qos permission create
no cable qos permission update
cable qos permission modems
cable logging badipsource 10000
cable logging layer2events 512000
cable time-server
!
! DSG configurations not shown, but could be present if supported
!
aaa new-model
!
aaa authentication login default group tacacs+ enable
aaa authentication enable default enable
aaa authorization config-commands
aaa authorization exec default group tacacs+ none
aaa authorization commands 15 default group tacacs+ none
aaa accounting exec default start-stop group tacacs+
aaa accounting commands 1 default start-stop group tacacs+
aaa accounting commands 15 default start-stop group tacacs+
aaa accounting network default start-stop group tacacs+
aaa accounting system default start-stop group tacacs+
aaa session-id common
ip subnet-zero
no ip source-route

```

```

no ip gratuitous-arps
!
ip tftp source-interface Loopback0
ip domain name <domain name>.<sub-domain>.com
ip host riverstone <ip address>
ip name-server <ip address>
ip name-server <ip address>
ip name-server <ip address>
ip dhcp relay information option
!
no ip bootp server
ip multicast-routing
ip multicast route-limit 250
ip igmp limit 500
!
! Certificate Entry
!
crypto ca trustpoint DOCSIS-ROOT-CERT
!
crypto ca trustpoint CN==<vendor name>,-OU==<vendor address>,-OU-
==DPOE,-O==<short vendor name>,-C==US
! followed by other vendor certificates
!
crypto ca trustpoint ffffffffffffffffffffffffffffffffffffffffff
!
crypto ca certificate chain DPoE-ROOT-CERT
certificate ca ffffffffffffffffffffffffffffffffff
ffffffff ffffffff ffffffff ffffffff ffffffff ffffffff ffffffff ffffffff
ffffffff ffffffff ffffffff ffffffff ffffffff ffffffff ffffffff ffffffff
ffffffff ffffffff ffffffff ffffffff ffffffff ffffffff ffffffff ffffffff
ffffffff ffffffff ffffffff ffffffff ffffffff ffffffff ffffffff ffffffff
ffffffff ffffffff ffffffff ffffffff ffffffff ffffffff ffffffff ffffffff
ffffffff ffffffff ffffffff ffffffff ffffffff ffffffff ffffffff ffffffff
ffffffff ffffffff ffffffff ffffffff ffffffff ffffffff ffffffff ffffffff
ffffffff ffffffff ffffffff ffffffff ffffffff ffffffff ffffffff ffffffff
ffffffff ffffffff ffffffff ffffffff ffffffff ffffffff ffffffff ffffffff
ffffffff ffffffff ffffffff ffffffff ffffffff ffffffff ffffffff ffffffff
ffffffff ffffffff ffffffff ffffffff ffffffff ffffffff ffffffff ffffffff
ffffffff ffffffff ffffffff ffffffff ffffffff ffffffff ffffffff ffffffff
ffffffff ffffffff ffffffff ffffffff ffffffff ffffffff ffffffff ffffffff
ffffffff ffffffff ffffffff ffffffff ffffffff ffffffff ffffffff ffffffff
ffffffff ffffffff ffffffff ffffffff ffffffff ffffffff ffffffff ffffffff
ffffffff ffffffff ffffffff ffffffff ffffffff ffffffff ffffffff ffffffff
ffffffff ffffffff ffffffff ffffffff ffffffff ffffffff ffffffff ffffffff
ffffffff ffffffff ffffffff ffffffff ffffffff ffffffff ffffffff ffffffff
ffffffff ffffffff ffffffff ffffffff ffffffff ffffffff ffffffff ffffffff
ffffffff ffffffff ffffffff ffffffff ffffffff ffffffff ffffffff ffffffff
quit
!
! followed by additional certificates
!
key chain dpoe-chain
key 1
  key-string 7 000000000000
key 2
  key-string 7 000000000000

```

```
!  
buffers small permanent 310  
buffers small max-free 515  
buffers small min-free 65  
buffers middle permanent 258  
buffers middle max-free 360  
buffers middle min-free 80  
buffers big permanent 528  
buffers big max-free 828  
buffers big min-free 180  
buffers verybig permanent 42  
buffers verybig max-free 43  
buffers verybig min-free 6  
!  
! I-BEB configuruation for DPoE  
ibeb 0000.0010.FF3C.ABCD  
!  
interface Loopback0  
description Loopback 0  
ip address 10.0.0.1/32  
no ip redirects  
no ip proxy-arp  
no ip mroute-cache  
no keepalive  
!  
interface FastEthernet0/0  
no ip address  
no ip redirects  
no ip proxy-arp  
load-interval 30  
shutdown  
duplex full  
!  
interface GigabitEthernet0/1  
no ip address  
shutdown  
duplex auto  
speed auto  
media-type rj45  
negotiation auto  
!  
interface GigabitEthernet0/2  
no ip address  
shutdown  
duplex auto  
speed auto  
media-type rj45  
negotiation auto  
!  
interface GigabitEthernet0/3  
no ip address  
shutdown  
duplex auto  
speed auto  
media-type rj45  
negotiation auto  
!  
Service-Class VIDEO-MGMT  
Polling-type RTPS  
Upstream rate 64kbps  
Downstream rate 64kbps  
!  
interface bundle 1  
DPoE System Bundle  
!  
interface bundle 1.1  
Description default IP-HSD interface
```

```
bundle 1
s-vlan 1001
docsis attribute-mask 80000001
ipv4 address 10.200.200.1 255.255.255.0
ipv6 address 2001:db8:1:1/64
ipv4 access-list 100 in
ipv4 access-list 101 out
ipv4 source-address verify
cable dhcp-giaddr primary [vCM giaddr]
ipv4 rip receive version 2
ipv4 rip authentication mode md5
ipv4 rip authentication key-chain <chain name>
no cable arp filter request-send
no cable arp filter reply-accept
cable source-verify dhcp
cable dhcp-parse option-43
cable dhcp-parse option-60
cable dhcp-giaddr primary
cable helper-address <ip address>
cable helper-address <ip address>
igmpv3
mldv2
!
interface bundle 1.3
description example eMTA IP Network
s-vlan 1003
docsis attribute-mask 80000001
ip address 10.200.201.1 255.255.255.0
ipv6 address 2001:db8:2:1/64
ip access-list 200 in
ip access-list 201 out
cable source-verify dhcp
cable dhcp-giaddr primary [vCM giaddr]

interface bundle 1.4
description Example eSTB IP Network
s-vlan 1004
docsis attribute-mask 80000004
Service-Class VIDEO-MGMT
ip address 10.200.202.1 255.255.255.0
ipv6 address 2001:db8:3:1/64
ip access-list 300 in
ip access-list 301 out
cable dhcp-giaddr primary [vCM giaddr]
!
!
interface tul/0
description EPON interface Slot 0, Port 0
no ip address
load-interval 30
cable shared-secret 7 00000000000000000000
cable enable-trap cmonoff-notification
cable enable-trap cmonoff-interval 600
bundle 1
no cable packet-cache
no shutdown
!
interface tul/1
description EPON interface Slot 0, Port 1
no ip address
load-interval 30
cable shared-secret 7 00000000000000000000
cable enable-trap cmonoff-notification
cable enable-trap cmonoff-interval 600
bundle 1
no cable packet-cache
no shutdown
```

```
!  
interface tul/2  
description EPON interface Slot 0, Port 2  
no ip address  
load-interval 30  
cable shared-secret 7 00000000000000000000  
cable enable-trap cmonoff-notification  
cable enable-trap cmonoff-interval 600  
bundle 1  
no cable packet-cache  
no shutdown  
!  
interface tul/3  
description EPON interface Slot 0, Port 3  
no ip address  
load-interval 30  
cable shared-secret 7 00000000000000000000  
cable enable-trap cmonoff-notification  
cable enable-trap cmonoff-interval 600  
bundle 1  
no cable packet-cache  
no shutdown  
!  
  
interface tul/4  
description EPON interface Slot 0, Port 4  
no ip address  
load-interval 30  
cable shared-secret 7 00000000000000000000  
cable enable-trap cmonoff-notification  
cable enable-trap cmonoff-interval 600  
bundle 1  
no cable packet-cache  
no shutdown  
!  
interface tul/5  
description EPON interface Slot 0, Port 5  
no ip address  
load-interval 30  
cable shared-secret 7 00000000000000000000  
cable enable-trap cmonoff-notification  
cable enable-trap cmonoff-interval 600  
bundle 1  
no cable packet-cache  
no shutdown  
!  
interface tul/6  
description EPON interface Slot 0, Port 6  
no ip address  
load-interval 30  
cable shared-secret 7 00000000000000000000  
cable enable-trap cmonoff-notification  
cable enable-trap cmonoff-interval 600  
bundle 1  
no cable packet-cache  
no shutdown  
!  
interface tul/7  
description EPON interface Slot 0, Port 7  
no ip address  
load-interval 30  
cable shared-secret 7 00000000000000000000  
cable enable-trap cmonoff-notification  
cable enable-trap cmonoff-interval 600  
bundle 1  
no cable packet-cache  
no shutdown
```



```
!  
interface tu2/0  
description EPON interface Slot 1, Port 0  
no ip address  
load-interval 30  
cable shared-secret 7 000000000000000000  
cable enable-trap cmonoff-notification  
cable enable-trap cmonoff-interval 600  
bundle 2  
no cable packet-cache  
no shutdown  
!  
!  
router ospf <ospf id>  
router-id <ip address>  
log-adjacency-changes  
passive-interface default  
no passive-interface SRP1/0  
network <network> <bit mask> area 1  
network <network> <bit mask> area 1  
network <network> <bit mask> area 1  
network <network> <bit mask> area 1  
network <network> <bit mask> area 1  
network <network> <bit mask> area 1  
network <network> <bit mask> area 1  
network <network> <bit mask> area 1  
network <network> <bit mask> area 1  
network <network> <bit mask> area 1  
!  
router rip  
version 2  
passive-interface default  
network 10.0.0.0  
distribute-list 40 in  
no auto-summary  
!  
router bgp <asn>  
no synchronization  
bgp log-neighbor-changes  
bgp graceful-restart restart-time 120  
bgp graceful-restart stalepath-time 360  
bgp graceful-restart  
network <ip address> mask <netmask>  
network <ip address> mask <netmask>  
network <ip address> mask <netmask>  
network <ip address> mask <netmask>  
redistribute rip route-map COMM-SVC-NETS  
neighbor RR-client peer-group  
neighbor RR-client remote-as <asn>  
neighbor RR-client update-source Loopback0  
neighbor RR-client next-hop-self  
neighbor RR-client send-community  
neighbor RR-client soft-reconfiguration inbound  
neighbor RR-client route-map CMTS-REG out  
neighbor <ip address>peer-group RR-client  
neighbor <ip address>peer-group RR-client  
no auto-summary  
!  
ip classless  
ip route <ip address> <network mask> FastEthernet0/0  
no ip http server  
no ip http secure-server  
ip tacacs source-interface Loopback0  
!  
ip prefix-list <list name> seq 5 permit <ip network>/<short mask>  
ip prefix-list <list name> seq 10 permit <ip network>/<short mask>  
!
```

```
ip access-list standard SSM-ALLOW-SRV
  permit <ip network><ip network mask>
  permit <ip network><ip network mask>
  permit <ip network><ip network mask>
ip access-list standard VLC1
  permit <ip address>
  permit <ip address>
  permit <ip address>
ip access-list standard VLC2
  permit <ip address>
  permit <ip address>
  permit <ip address>
ip access-list standard VLC3
  permit <ip address>
  permit <ip address>
  permit <ip address>
  permit <ip address>
  permit <ip address>
  permit <ip address>
  permit <ip address>
  permit <ip address>
  permit <ip address>
  permit <ip address>
ip access-list standard div-multicast
  permit <ip network> <ip network mask>
  permit <ip network><ip network mask>
ip access-list standard groups1
  permit <ip address>
  permit <ip address>
ip access-list standard groups2
  permit <ip address>
!
ip access-list extended cops
  permit ip host <ip address> host <ip address>
  permit ip host <ip address> host <ip address>
  permit ip host <ip address> host <ip address>
  permit ip host <ip address> host <ip address>
  permit ip host <ip address> host <ip address>
  permit ip host <ip address> host <ip address>
  permit ip host <ip address> host <ip address>
  permit ip host <ip address> host <ip address>
ip access-list extended list1
  permit ip any host <ip address>
  permit ip any host <ip address>
  permit ip any host <ip address>
  permit ip any host <ip address>
  permit ip any host <ip address>
ip access-list extended list2
  permit ip any host <ip address>
  permit ip any host <ip address>
  permit ip any host <ip address>
  permit ip any host <ip address>
  permit ip any host <ip address>
ip access-list extended list3
  permit ip any host <ip address>
  permit ip any host <ip address>
  permit ip any host <ip address>
  permit ip any host <ip address>
  permit ip any host <ip address>
ip access-list extended list4
  permit ip any host <ip address>
  permit ip any host <ip address>
  permit ip any host <ip address>
  permit ip any host <ip address>
  permit ip any host <ip address>
logging facility local6
logging source-interface Loopback0
```

```

logging <ip address>
logging <ip address>
logging <ip address>
logging <ip address>
access-list 5 permit <ip network> <ip network mask> log
access-list 5 permit <ip network> <ip network mask> log
access-list 5 permit <ip network> <ip network mask> log
access-list 5 permit <ip network> <ip network mask> log
access-list 5 permit <ip network> <ip network mask> log
access-list 5 permit <ip network> <ip network mask> log
access-list 6 permit <ip address>
access-list 6 permit <ip address>
access-list 6 permit <ip address>
access-list 6 permit <ip address>
access-list 6 permit <ip network> <ip network mask>
access-list 6 permit <ip network> <ip network mask>
access-list 6 permit <ip network> <ip network mask>
access-list 6 permit <ip network> <ip network mask>
access-list 6 permit <ip network> <ip network mask>
access-list 7 permit <ip network> <ip network mask>
access-list 7 permit <ip network> <ip network mask>
access-list 7 permit <ip network> <ip network mask>
access-list 7 permit <ip network> <ip network mask>
access-list 7 permit <ip network> <ip network mask>
access-list 8 permit <ip network> <ip network mask>
access-list 20 permit <ip network> <ip network mask>
access-list 20 permit <ip network> <ip network mask>
access-list 20 permit <ip network> <ip network mask>
access-list 20 permit <ip network> <ip network mask>
access-list 20 permit <ip network> <ip network mask>
access-list 20 permit <ip network> <ip network mask>
access-list 20 permit <ip network> <ip network mask>
access-list 20 permit <ip network> <ip network mask>
access-list 20 permit <ip network> <ip network mask>
access-list 20 permit <ip network> <ip network mask>
access-list 40 permit <ip network> <ip network mask>
access-list 40 permit <ip network> <ip network mask>
access-list 157 permit udp any eq rip any eq rip
access-list 157 permit igmp any <ip network> <ip network mask>
access-list 157 permit igmp any <ip network> <ip network mask>
access-list 157 permit igmp any <ip network> <ip network mask>
access-list 157 permit udp any host <ip address>
access-list 157 deny igmp any any
access-list 157 deny icmp any <ip network> <ip network mask>
access-list 157 deny tcp any <ip network> <ip network mask>
access-list 157 deny udp any <ip network> <ip network mask>
access-list 157 permit ip any any
access-list 160 permit ip <ip network> <ip network mask> any
access-list 160 permit ip <ip network> <ip network mask> any
access-list 160 permit udp any any range bootps bootpc
access-list 160 deny ip any any log
!
nls resp-timeout 1
cpd cr-id 1
!
route-map COMM-SVC-NETS permit 10
  match ip address 40
!
route-map CMTS-REG permit 10
  match ip address prefix-list <list name>
!
route-map CMTS-REG permit 20
  match ip address prefix-list <list name>
!
route-map CMTS-REG permit 30
  match ip address 40
!
snmp-server engineID local 000000000000000000000000
snmp-server community <string name> RO
snmp-server community <string name>RO 6
snmp-server community <string name>RO

```

```

snmp-server trap-source Loopback0
snmp-server location <address or description>
snmp-server contact <first name> <last name> <tel #>
snmp-server chassis-id <id>
snmp-server enable traps snmp authentication linkdown linkup coldstart warmstart
snmp-server enable traps atm pvc
snmp-server enable traps config
snmp-server enable traps entity
snmp-server enable traps envmon
snmp-server enable traps rtr
snmp-server host <ip address> <hostname or description>
snmp-server host <ip address> <hostname or description>
snmp-server host <ip address> <hostname or description>
snmp-server host <ip address> <hostname or description>
snmp-server host <ip address> <hostname or description>
snmp-server host <ip address> <hostname or description>
snmp-server manager
tftp-server disk2:<image name>.bin
tacacs-server host <ip address>
tacacs-server host <ip address>
tacacs-server directed-request
tacacs-server key 7 <key>
!
banner motd ^CCCCC
                *****Warning Notice*****
This system is restricted solely to <operator> authorized users for
<>
                ***** Network Operations Center <> *****
^C

! alias commands not shown
privilege exec level 1 show ip interface brief
privilege exec level 1 show ip interface
privilege exec level 1 show ip
privilege exec level 1 show cable flap-list
privilege exec level 1 show cable modem
privilege exec level 1 show cable qos profile
privilege exec level 15 show cable qos
privilege exec level 1 show cable
privilege exec level 1 show controllers
privilege exec level 1 show interfaces
privilege exec level 1 show running-config
privilege exec level 1 show
privilege exec level 15 clear cable host
privilege exec level 15 clear cable flap-list all
privilege exec level 15 clear cable flap-list
privilege exec level 15 clear cable
privilege exec level 15 clear
!
line con 0
  exec-timeout 30 0
  logging synchronous
  transport preferred telnet
  transport output telnet
  stopbits 1
line aux 0
  transport preferred none
  transport output none
  stopbits 1
line vty 0 4
  access-class 5 in
  exec-timeout 60 0
  password 7 000000000000
  exec prompt timestamp
  transport preferred telnet
  transport input all
  transport output all

```

```
line vty 5 15
  access-class 5 in
  exec-timeout 30 0
  password 7 000000000000
  exec prompt timestamp
  transport preferred telnet
  transport input telnet
  transport output telnet
!
exception crashinfo file disk0:crashinfo
scheduler allocate 3999 400
ntp clock-period 17179904
ntp source Loopback0
ntp update-calendar
ntp server <ip address>
ntp server <ip address>
ntp peer <ip address>
end
```

## Appendix V Acknowledgements (Informative)

On behalf of our industry, we would like to thank the following individuals for their contributions to the development of this specification.

**Contributor**

John Dickinson, Edwin Mallette

Shamim Akhtar, Phillip Chang, Jason Combs, Doug Jones, Saif Rahman,  
Matt Scully, Rashid Siddiqui, Mehmet Toy, Bin Wen

Victor Blake

Ron daSilva, Robert Harris, Shan Huang, Mike Kelsen, Tushar Nakhre,  
Karen Rice

**Company Affiliation**

Bright House Networks

Comcast

Independent Consultant

Time Warner Cable

## Appendix VI Revision History

### VI.1 Engineering Change for DPoE-SP-IPNEv2.0-I02-131114

The following Engineering Change was incorporated into DPoE-SP-IPNEv2.0-I02-131114

ECN	Date Accepted	Summary	Author
IPNEv2.0-N-13.0104-1	10/3/2013	EC to remove TU Forwarding Performance Requirements	Edwin Mallette

### VI.2 Engineering Changes for DPoE-SP-IPNEv2.0-I03-140807

The following Engineering Changes were incorporated into DPoE-SP-IPNEv2.0-I03-140807

ECN	Date Accepted	Summary	Author
IPNEv2.0-N-14.0141-1	4/11/2014	IP(HSD) changes for IPNE 2.0	Steve Burroughs
IPNEv2.0-N-14.0166-2	7/3/2014	Removal of Dual Provisioning Mode	Jun Tan
IPNEv2.0-N-14.0170-1	7/3/2014	Alignment and cleanup of 802.3 references	Marek Hajduczenia
IPNEv2.0-N-14.0186-1	7/10/2014	DPoEv2 IPNE Edits to Support 2G-EPON	Lane Johnson

### VI.3 Engineering Change for DPoE-SP-IPNEv2.0-I04-150319

The following Engineering Change were incorporated into DPoE-SP-IPNEv2.0-I04-150319

ECN	Date Accepted	Summary	Author
IPNEv2.0-N-14.0197-1	10/30/2014	Support for Power Saving mechanism	Marek Hajduczenia

### VI.4 Engineering Change for DPoE-SP-IPNEv2.0-I05-150611

The following Engineering Change were incorporated into DPoE-SP-IPNEv2.0-I05-150611

ECN	Date Accepted	Summary	Author
IPNEv2.0-N-15.0207-1	4/3/2015	DPoE IPNE 2.0 L2HSD	Arkin Aydin