

DOCSIS® Provisioning of EPON Specifications

DPoEv2.0

DPoE OAM Extensions Specification

DPoE-SP-OAMv2.0-I11-170510

ISSUED

Notice

This DPoE™ specification is the result of a cooperative effort undertaken at the direction of Cable Television Laboratories, Inc. for the benefit of the cable industry and its customers. You may download, copy, distribute, and reference the documents herein only for the purpose of developing products or services in accordance with such documents, and educational use. Except as granted by CableLabs® in a separate written license agreement, no license is granted to modify the documents herein (except via the Engineering Change process), or to use, copy, modify or distribute the documents for any other purpose.

This document may contain references to other documents not owned or controlled by CableLabs. Use and understanding of this document may require access to such other documents. Designing, manufacturing, distributing, using, selling, or servicing products, or providing services, based on this document may require intellectual property licenses from third parties for technology referenced in this document. To the extent this document contains or refers to documents of third parties, you agree to abide by the terms of any licenses associated with such third-party documents, including open source licenses, if any.

DISCLAIMER

This document is furnished on an "AS IS" basis and neither CableLabs nor its members provides any representation or warranty, express or implied, regarding the accuracy, completeness, noninfringement, or fitness for a particular purpose of this document, or any document referenced herein. Any use or reliance on the information or opinion in this document is at the risk of the user, and CableLabs and its members shall not be liable for any damage or injury incurred by any person arising out of the completeness, accuracy, or utility of any information or opinion contained in the document.

CableLabs reserves the right to revise this document for any reason including, but not limited to, changes in laws, regulations, or standards promulgated by various entities, technology advances, or changes in equipment design, manufacturing techniques, or operating procedures described, or referred to, herein.

This document is not to be construed to suggest that any company modify or change any of its products or procedures, nor does this document represent a commitment by CableLabs or any of its members to purchase any product whether or not it meets the characteristics described in the document. Unless granted in a separate written agreement from CableLabs, nothing contained herein shall be construed to confer any license or right to any intellectual property. This document is not to be construed as an endorsement of any product or company or as the adoption or promulgation of any guidelines, standards, or recommendations.

Document Status Sheet

Document Control Number:	DPoE-SP-OAMv2.0-I11-170510			
Document Title:	DPoE OAM Extensions Specification			
Revision History:	I01 - Released 10/04/2012 I02 - Released 03/28/2013 I03 - Released 08/08/2013 I04 - Released 11/14/2013 I05 - Released 03/27/2014 I06 - Released 08/07/2014 I07 - Released 03/19/2015 I08 - Released 12/10/2015 I09 - Released 06/02/2016 I10 - Released 01/11/2017 I10 - Released 05/10/2017			
Date:	May 10, 2017			
Status:	Work in Progress	Draft	Issued	Closed
Distribution Restrictions:	Author Only	CL/Member	CL/Member/Vendor	Public

Key to Document Status Codes

- Work in Progress** An incomplete document, designed to guide discussion and generate feedback that may include several alternative requirements for consideration.
- Draft** A document in specification format considered largely complete, but lacking review by Members and vendors. Drafts are susceptible to substantial change during the review process.
- Issued** A generally public document that has undergone Member and Technology Supplier review, cross-vendor interoperability, and is for Certification testing if applicable. Issued Specifications are subject to the Engineering Change Process.
- Closed** A static document, reviewed, tested, validated, and closed to further engineering change requests to the specification through CableLabs.

Trademarks

CableLabs® is a registered trademark of Cable Television Laboratories, Inc. Other CableLabs marks are listed at <http://www.cablelabs.com/certqual/trademarks>. All other marks are the property of their respective owners.

Contents

1	INTRODUCTION	15
1.1	DPoE Technology Introduction	15
1.2	Scope	16
1.3	DPoE OAM Specification Goals	16
1.4	Requirements	17
1.5	DPoE Version 2.0 Specifications.....	17
1.6	Reference Architecture	18
1.7	DPoE Interfaces and Reference Points	19
2	REFERENCES	22
2.1	Normative References.....	22
2.2	Informative References.....	23
2.3	Reference Acquisition.....	24
3	TERMS AND DEFINITIONS	25
3.1	DPoE Network Elements	25
3.2	Other Terms	27
4	ABBREVIATIONS AND ACRONYMS.....	28
5	BACKGROUND.....	31
5.1	IEEE 802 Link OAM for EPON	31
5.2	[802.3] Clause 57 OAM PDUs	31
5.2.1	<i>Info PDU</i>	32
5.2.2	<i>Event Notification PDU</i>	33
5.2.3	<i>Variable Request/Response PDUs</i>	34
5.2.4	<i>Loopback Control PDU</i>	34
5.2.5	<i>Organization-specific PDU</i>	34
5.3	D-ONU Model	35
5.4	Frame Processing.....	35
6	OAM OPERATION	37
6.1	OAM Discovery.....	37
6.2	OAM Timeout	37
6.3	Critical OAM.....	37
6.3.1	<i>D-ONU Capabilities</i>	38
6.3.2	<i>Set D-ONU Report Threshold</i>	38
6.3.3	<i>Set OAM Rate</i>	38
6.4	OAM Keep-alive Failure	38
6.5	OAM and Logical Links	39
7	[802.3] OAM PDU.....	40
7.1	Info PDU.....	40
7.1.1	<i>Info TLV: DPoE OAM Support (0x00)</i>	40
7.2	Event Notification PDU.....	41
7.2.1	<i>LOS (0x11)</i>	43
7.2.2	<i>Key Exchange Failure (0x12)</i>	43
7.2.3	<i>Port Disable (0x21)</i>	43
7.2.4	<i>Power Failure (0x41)</i>	43
7.2.5	<i>Statistics Alarm (0x81)</i>	43
7.2.6	<i>D-ONU Busy (0x82)</i>	43
7.2.7	<i>MAC Table Overflow (0x83)</i>	43

8	DPOE OAM PDUS	44
8.1	Definitions of DPoE OAM PDUs	45
8.1.1	<i>Get Request</i>	45
8.1.2	<i>Get Response</i>	45
8.1.3	<i>Set Request</i>	45
8.1.4	<i>Set Response</i>	45
8.1.5	<i>Key Exchange</i>	45
8.1.6	<i>File Transfer</i>	46
8.1.7	<i>eOAM_Early_WakeUpOLT</i>	46
8.1.8	<i>eOAM_Early_WakeUpONU</i>	46
8.1.9	<i>eOAM_Sleep_Allowed</i>	46
8.2	Attribute List.....	46
8.3	Data Formats.....	47
8.3.1	<i>Integers</i>	47
8.3.2	<i>Enumerated Values</i>	47
8.3.3	<i>Sequences</i>	47
8.3.4	<i>Structured Data Types</i>	47
8.4	Storage Classes	48
8.5	Large Values.....	48
8.6	Multiple Part OAM Responses	48
8.7	Object Context (Branch 0xD6).....	50
8.7.1	<i>D-ONU Object (0xD6/0x0000)</i>	50
8.7.2	<i>Network Port Object (0xD6/0x0001)</i>	50
8.7.3	<i>Unicast Logical Link (0xD6/0x0002)</i>	51
8.7.4	<i>User Port Object (0xD6/0x0003)</i>	51
8.7.5	<i>Queue Object (0xD6/0x0004)</i>	51
8.7.6	<i>Multicast Logical Link Object (0xD6/0x0006)</i>	51
8.8	Broadcast eOAM	52
8.9	Reserved Branch (0xC7).....	52
9	OAM ATTRIBUTES BY FUNCTION	53
9.1	D-ONU Management.....	53
9.1.1	<i>Device ID (0xD7/0x0002) R</i>	53
9.1.2	<i>Firmware Info (0xD7/0x0003) R</i>	53
9.1.3	<i>Chipset Info (0xD7/0x0004) R</i>	54
9.1.4	<i>Date of Manufacture (0xD7/0x0005) R</i>	54
9.1.5	<i>Manufacturer Info (0xD7/0x0006) R</i>	54
9.1.6	<i>Max Logical Links (0xD7/0x0007) R</i>	54
9.1.7	<i>Number of Network Ports (0xD7/0x0008) R</i>	55
9.1.8	<i>Number of S₁ interfaces (0xD7/0x0009) R</i>	55
9.1.9	<i>D-ONU Packet Buffer (0xD7/0x000A) R</i>	55
9.1.10	<i>Report Thresholds (0xD7/0x000B)</i>	55
9.1.11	<i>Logical Link Forwarding State (0xD7/0x000C) R</i>	56
9.1.12	<i>OAM Frame Rate (0xD7/0x000D)</i>	56
9.1.13	<i>ONU Manufacturer Organization Name (0xD7/0x000E) R</i>	56
9.1.14	<i>Firmware Mfg Time Varying Controls (0xD7/0x000F) NVS</i>	57
9.1.15	<i>D-ONU Port Type (0xD7/0x0010)</i>	57
9.1.16	<i>Vendor Name (D7/00 11) R</i>	58
9.1.17	<i>Model Number (D7/00 12) R</i>	58
9.1.18	<i>Hardware Version (D7/00 13) R</i>	58
9.1.19	<i>EPON Mode (D7/00 14) R</i>	59
9.1.20	<i>Software Bundle (0xD7/0x0015) R</i>	59
9.1.21	<i>Reset D-ONU (0xD9/0x0001)</i>	60
9.2	Bridging	60
9.2.1	<i>Dynamic Learning Table Size (0xD7/0x0101) R</i>	60

9.2.2	<i>Dynamic Address Age Limit (0xD7/0x0102)</i>	60
9.2.3	<i>Dynamic MAC Table (0xD7/0x0103) R</i>	60
9.2.4	<i>Static MAC Table (0xD7/0x0104) R</i>	60
9.2.5	<i>S₁ Interface Port Auto-negotiation (0xD7/0x0105)</i>	61
9.2.6	<i>Source Address Admission Control (0xD7/0x0106)</i>	61
9.2.7	<i>MAC Learning Min Guarantee (0xD7/0x0107)</i>	62
9.2.8	<i>MAC Learning Max Allowed (0xD7/0x0108)</i>	62
9.2.9	<i>MAC Learning Aggregate Limit (0xD7/0x0109)</i>	62
9.2.10	<i>Len Error Discard (0xD7/0x010A)</i>	62
9.2.11	<i>Flood Unknown (0xD7/0x010B)</i>	63
9.2.12	<i>Local Switching (0xD7/0x010C)</i>	63
9.2.13	<i>LLID and Queue Configuration (0xD7/0x010D)</i>	63
9.2.14	<i>Firmware Filename (0xD7/0x010E) NVS R</i>	64
9.2.15	<i>MAC Table Full Behavior (0xD7/0x010F)</i>	64
9.2.16	<i>Multicast LLID (0xD7/0x0110)</i>	65
9.2.17	<i>UNI MAC Learned (0xD7/0x0111)</i>	65
9.2.18	<i>Clear Dynamic MAC Table (0xD9/0x0101)</i>	65
9.2.19	<i>Add Dynamic MAC Address (0xD9/0x0102)</i>	65
9.2.20	<i>Delete Dynamic MAC Address (0xD9/0x0103)</i>	65
9.2.21	<i>Configure eSAFE (0xD7/0x0116)</i>	65
9.2.22	<i>Enable/Disable eMTA/eDVA (0xD7/0x0117)</i>	66
9.2.23	<i>Clear Static MAC Table (0xD9/0x0104)</i>	67
9.2.24	<i>Add Static MAC Address (0xD9/0x0105)</i>	67
9.2.25	<i>Delete Static MAC Address (0xD9/0x0106)</i>	67
9.2.26	<i>Config Multicast LLID (0xD9/0x0107)</i>	67
9.3	Statistics And Counters	67
9.3.1	<i>Rx Frames Green (0xD7/0x0201)</i>	67
9.3.2	<i>Tx Frames Green (0xD7/0x0202)</i>	68
9.3.3	<i>Rx Frame Too Short (0xD7/0x0203)</i>	68
9.3.4	<i>Rx Frame 64 (0xD7/0x0204)</i>	68
9.3.5	<i>Rx Frame 65_127 (0xD7/0x0205)</i>	68
9.3.6	<i>Rx Frame 128_255 (0xD7/0x0206)</i>	69
9.3.7	<i>Rx Frame 256_511 (0xD7/0x0207)</i>	69
9.3.8	<i>Rx Frame 512_1023 (0xD7/0x0208)</i>	69
9.3.9	<i>Rx Frame 1024_1518 (0xD7/0x0209)</i>	69
9.3.10	<i>Rx Frame 1519 Plus (0xD7/0x020A)</i>	69
9.3.11	<i>Tx Frame 64 (0xD7/0x020B)</i>	70
9.3.12	<i>Tx Frame 65_127 (0xD7/0x020C)</i>	70
9.3.13	<i>Tx Frame 128_255 (0xD7/0x020D)</i>	70
9.3.14	<i>Tx Frame 256_511 (0xD7/0x020E)</i>	70
9.3.15	<i>Tx Frame 512_1023 (0xD7/0x020F)</i>	70
9.3.16	<i>Tx Frame 1024_1518 (0xD7/0x0210)</i>	71
9.3.17	<i>Tx Frame 1519 Plus (0xD7/0x0211)</i>	71
9.3.18	<i>Queue Delay Threshold (0xD7/0x0212)</i>	71
9.3.19	<i>Queue Delay (0xD7/0x0213)</i>	71
9.3.20	<i>Frames Dropped (0xD7/0x0214)</i>	71
9.3.21	<i>Bytes Dropped (0xD7/0x0215)</i>	72
9.3.22	<i>Bytes Delayed (0xD7/0x0216)</i>	72
9.3.23	<i>Tx Bytes Unused (0xD7/0x0217)</i>	72
9.3.24	<i>Optical Mon Temperature (0xD7/0x021D)</i>	73
9.3.25	<i>Optical Mon Vcc (0xD7/0x021E)</i>	73
9.3.26	<i>Optical Mon Tx Bias Current (0xD7/0x021F)</i>	73
9.3.27	<i>Optical Mon Tx Power (0xD7/0x0220)</i>	73
9.3.28	<i>Optical Mon Rx Power (0xD7/0x0221)</i>	73
9.3.29	<i>Rx Frames Yellow (0xD7/0x0222)</i>	74
9.3.30	<i>Tx Frames Yellow (0xD7/0x0223)</i>	74

9.3.31	<i>Tx Bytes Green (0xD7/0x0224)</i>	74
9.3.32	<i>Rx Bytes Yellow (0xD7/0x0225)</i>	74
9.3.33	<i>Rx Bytes Green (0xD7/0x0226)</i>	74
9.3.34	<i>Tx Bytes Yellow (0xD7/0x0227)</i>	75
9.3.35	<i>Tx Frames Unicast (0xD7/0x0228)</i>	75
9.3.36	<i>Tx Frames Multicast (0xD7/0x0229)</i>	75
9.3.37	<i>Tx Frames Broadcast (0xD7/0x022A)</i>	75
9.3.38	<i>Rx Frames Unicast (0xD7/0x022B)</i>	75
9.3.39	<i>Rx Frames Multicast (0xD7/0x022C)</i>	76
9.3.40	<i>Rx Frames Broadcast (0xD7/0x022D)</i>	76
9.3.41	<i>Number of Programmable Counters (0xD7/0x022E) R</i>	76
9.3.42	<i>L2CP Frames Rx (0xD7/0x022F)</i>	76
9.3.43	<i>L2CP Octets Rx (0xD7/0x0230)</i>	76
9.3.44	<i>L2CP Frames Tx (0xD7/0x0231)</i>	77
9.3.45	<i>L2CP Octets Tx (0xD7/0x0232)</i>	77
9.3.46	<i>L2CP Frames Discarded (0xD7/0x0233)</i>	77
9.3.47	<i>L2CP Octets Discarded (0xD7/0x0234)</i>	77
9.3.48	<i>Tx L2 Errors (0xD7/0x0235)</i>	78
9.3.49	<i>Rx L2 Errors (0xD7/0x0236)</i>	78
9.3.50	<i>Clear Counters (0xD9/0x0201)</i>	78
9.3.51	<i>Programmable Frame/Byte Counter (0xD8/nnnn) R</i>	78
9.4	Alarms.....	78
9.4.1	<i>Port Stat Threshold (0xD7/0x0301)</i>	78
9.4.2	<i>Link Stat Threshold (0xD7/0x0302)</i>	79
9.4.3	<i>Suspend/Resume Alarm Reporting (0xD7/0x0303)</i>	79
9.4.4	<i>Retrieve Current Alarm Summary (0xD9/0x0301)</i>	80
9.5	Security.....	80
9.5.1	<i>Encryption Key Expiry Time (0xD7/0x0401)</i>	80
9.5.2	<i>Encryption Mode (0xD7/0x0402)</i>	80
9.6	Frame Processing.....	80
9.6.1	<i>Port Ingress Rule (0xD7/0x0501)</i>	80
9.6.2	<i>Custom Field (0xD7/0x0502)</i>	86
9.6.3	<i>C-VLAN TPID (0xD7/0x0503)</i>	90
9.6.4	<i>S-VLAN TPID (0xD7/0x0504)</i>	91
9.6.5	<i>Reserved (0xD7/0x0505)</i>	91
9.6.6	<i>I-TPID (0xD7/0x0506)</i>	91
9.6.7	<i>B-TPID (0xD7/0x0507)</i>	91
9.6.8	<i>Clear Port Ingress Rules (0xD9/0x0501)</i>	92
9.6.9	<i>Add Port Ingress Rule (0xD9/0x0502)</i>	92
9.6.10	<i>Delete Port Ingress Rule (0xD9/0x0503)</i>	92
9.7	Service Level Agreements.....	92
9.7.1	<i>Broadcast Rate Limit (0xD7/0x0601)</i>	92
9.7.2	<i>Obsolete (0xD7/0x0602)</i>	92
9.7.3	<i>Obsolete (0xD7/0x0603)</i>	92
9.7.4	<i>Queue Committed Information Rate (0xD7/0x0604)</i>	92
9.7.5	<i>FEC Mode (0xD7/0x0605)</i>	93
9.7.6	<i>Queue Excess Information Rate (0xD7/0x0606)</i>	93
9.7.7	<i>Queue Color Marking (0xD7/0x0607)</i>	93
9.7.8	<i>Queue Rate Limiter Capabilities (0xD7/0x0608) R</i>	94
9.7.9	<i>Coupling Flag (0xD7/0x0609)</i>	94
9.7.10	<i>Enable User Traffic (0xD9/0x0601)</i>	95
9.7.11	<i>Disable User Traffic (0xD9/0x0602)</i>	95
9.7.12	<i>Loopback Enable (0xD9/0x0603)</i>	95
9.7.13	<i>Loopback Disable (0xD9/0x0604)</i>	96
9.7.14	<i>Laser Tx Power Off (0xD9/0x0605)</i>	97
9.8	Clock Transport.....	97

9.8.1	<i>Clock Transport Capabilities (0xD7/0x0701) R</i>	97
9.8.2	<i>Enable Clock Transport (0xD7/0x0702)</i>	97
9.8.3	<i>Time Transfer (0xD7/0x0703)</i>	97
9.8.4	<i>Propagation Parameters (0xD7/0x0704)</i>	98
9.8.5	<i>RTT (0xD7/0x0705)</i>	98
9.9	DEMARC Automatic Configuration.....	98
9.9.1	<i>Reserved (0xD7/0x0800)</i>	98
9.9.2	<i>Reserved (0xD7/0x0801)</i>	98
9.9.3	<i>Reserved (0xD7/0x0802)</i>	98
9.9.4	<i>Reserved (0xD7/0x0803)</i>	98
9.10	UNI management.....	98
9.10.1	<i>Energy Efficient Ethernet (EEE) status (0xD7/0x0820)</i>	99
9.10.2	<i>Power over Ethernet (PoE) status (0xD7/0x0821)</i>	99
9.10.3	<i>Media Type (0xD7/0x0822)</i>	99
9.11	Optical Link Protection R.....	99
9.11.1	<i>ONU Protection Capability (0xD7/0x09-00)</i>	99
9.11.2	<i>ONU Protection Configuration (0xD7/0x09-01)</i>	100
9.11.3	<i>PON Interface Administrative (0xD7/0x09-02)</i>	100
9.11.4	<i>ONU Config Holdover Period (0xD7/0x09-03)</i>	100
9.12	Power Saving.....	100
9.12.1	<i>ONU Power Saving Capabilities aOnuPwrSavingCap (0xD7/0xFFFF)</i>	100
10	MULTICAST LOGICAL LINK REGISTRATION	101
11	SECURITY	102
11.1	Key Exchange.....	102
12	FILE TRANSFER	103
12.1	File Transfer PDU Header.....	103
12.1.1	<i>File Transfer Write Request</i>	104
12.1.2	<i>File Transfer Data</i>	104
12.1.3	<i>File Transfer Ack</i>	104
APPENDIX I BRANCH/LEAF CODE REFERENCE (INFORMATIVE)		106
I.1	[802.3] Clause 30 Attributes (Branch 0x07).....	106
I.2	DPoE Attributes (Branch 0xD7).....	107
I.3	[802.3] Clause 30 Actions (Branch 09) (Informative).....	111
I.4	DPoE Actions (Branch 0xD9).....	111
APPENDIX II EXAMPLE PDUS (INFORMATIVE)		112
II.1	Get and Get Response.....	112
II.2	Set and Set Response.....	113
II.3	Large Attribute Values.....	114
II.4	Multi-Part Replies.....	114
II.5	Encryption and Key Exchange Messages.....	116
II.5.1	<i>Set Key Exchange Timer Response PDU</i>	117
II.5.2	<i>Get Key Exchange Timer PDU</i>	118
II.5.3	<i>Get Key Exchange Timer Response PDU</i>	119
II.6	Key Exchange Message.....	120
II.7	Example 1Down Key Exchange Sequence.....	120
II.8	LLID and Queue Configuration TLV.....	121
APPENDIX III LIFE CYCLE OF A UNICAST LOGICAL LINK (INFORMATIVE)		122
III.1	MPCP Registration.....	122
III.2	OAM Discovery.....	123
III.3	Establish Discovery.....	123

III.4	Provision Basic Link Properties.....	123
III.5	Provision Configuration Based on Services.....	123
III.6	In Service Operations	123
III.7	Link Deregistration	123
APPENDIX IV	EXAMPLE RULES (INFORMATIVE)	124
IV.1	Field Masking Example	124
IV.2	TPID Translation	127
APPENDIX V	ACKNOWLEDGEMENTS	128
APPENDIX VI	REVISION HISTORY	129
VI.1	Engineering Changes for DPoE-SP-OAMv2.0-I02-130328.....	129
VI.2	Engineering Changes for DPoE-SP-OAMv2.0-I03-130808.....	129
VI.3	Engineering Change for DPoE-SP-OAMv2.0-I04-131114	129
VI.4	Engineering Change for DPoE-SP-OAMv2.0-I05-140327	129
VI.5	Engineering Changes for DPoE-SP-OAMv2.0-I06-140807.....	129
VI.6	Engineering Changes for DPoE-SP-OAMv2.0-I07-150319.....	130
VI.7	Engineering Changes for DPoE-SP-OAMv2.0-I08-151210.....	130
VI.8	Engineering Changes for DPoE-SP-OAMv2.0-I09-160602.....	130
VI.9	Engineering Change for DPoE-SP-OAMv2.0-I10-170111	130
VI.10	Engineering Change for DPoE-SP-OAMv2.0-I11-170510	130

Figures

Figure 1 - DPoEv2.0 Reference Architecture	18
Figure 2 - DPoEv2.0 Interfaces and Reference Points.....	19
Figure 3 - D-ONU Types	26
Figure 4 - DPoE Network Elements	26
Figure 5 - D-ONU Model	35
Figure 6 - Sample Message Exchange	49
Figure 7 - Preamble/L2 without SNAP.....	87
Figure 8 - Preamble/L2 with SNAP.....	87
Figure 9 - [802.1ah] Layer.....	88
Figure 10 - EtherType Layer	88
Figure 11 - S-VLAN Layer.....	88
Figure 12 - C-VLAN Layer	89
Figure 13 - MPLS LSEs Layer	89
Figure 14 - IPv4 Layer.....	89
Figure 15 - IPv6 Layer.....	90
Figure 16 - Layer TCP/UDP.....	90
Figure 17 - Set Loopback for D-ONU S ₁ Interface	95
Figure 18 - Enable/Disable Loopback	96
Figure 19 - Get and Get Response	112
Figure 20 - Set and Set Response	113
Figure 21 - Large Attribute Values.....	114
Figure 22 - Multi-Part Replies	115
Figure 23 - Set Key Exchange Timer Request PDU.....	116
Figure 24 - Set Key Exchange Timer Response PDU	117
Figure 25 - Get Key Exchange Timer PDU.....	118
Figure 26 - Get Key Exchange Timer Response PDU.....	119
Figure 27 - Unicast Logical Link Life Cycle.....	122
Figure 28 - Field Masking Example for Untagged Frame	124
Figure 29 - Field Masking Example for 802.1Q C-tagged Frame	125
Figure 30 - Field Masking Example for 802.1ad Tagged Frame.....	126
Figure 31 - Field Masking Example for 802.1ah Encapsulated 802.1ad Tagged Frame	127

Tables

Table 1 - DPoE 2.0 Series of Specifications.....	17
Table 2 - DPoEv2.0 Interface and Reference Point Descriptions.....	20
Table 3 - IEEE Link OAM Messages Format	32
Table 4 - [802.3] Clause 57 PDU Types.....	32
Table 5 - [802.3] Info TLV.....	32
Table 6 - [802.3] Info TLV Types	33
Table 7 - [802.3] Event Notification TLV	33
Table 8 - [802.3] Link Event TLV Types	33
Table 9 - Critical OAM Attributes.....	37
Table 10 - DPoE Info TLV Format	40
Table 11 - DPoE Info TLV Types	40
Table 12 - DPoE OAM Support TLV Format	41
Table 13 - DPoE Link Event TLV Format	41
Table 14 - DPoE Event Codes	42
Table 15 - Statistics Alarms Additional Fields	43
Table 16 - DPoE Extended OAM PDU Format.....	44
Table 17 - DPoE Opcodes	44
Table 18 - Variable Descriptor	46
Table 19 - Variable Container	46
Table 20 - DPoE Variable Response Codes	47
Table 21 - Sequence Number TLV.....	49
Table 22 - Object Context.....	50
Table 23 - D-ONU Object	50
Table 24 - Network Port Object.....	51
Table 25 - Unicast Logical Link Object	51
Table 26 - User Port Object.....	51
Table 27 - Queue Object.....	51
Table 28 - Multicast Logical Link Object.....	51
Table 29 - Firmware Info.....	53
Table 30 - Chipset Info.....	54
Table 31 - Date of Manufacture.....	54
Table 32 - Manufacturer Info	54
Table 33 - Max Logical Links	54
Table 34 - D-ONU Packet Buffer.....	55
Table 35 - Report Thresholds	55
Table 36 - Link State	56
Table 37 - OAM Frame Rate	56
Table 38 - ONU Manufacturer Organization Name	57
Table 39 - Firmware Mfg Time Varying Controls	57
Table 40 - D-ONU Port Type.....	57
Table 41 - Port type enumeration	58
Table 42 - ONU Manufacturer Organization Name	58

Table 43 - ONU Model Number.....	58
Table 44 - ONU Hardware Version.....	59
Table 45 - ONU EPON Mode	59
Table 46 - ONU EPON Mode Capabilities Bit Value	59
Table 47 - ONU Hardware Version.....	60
Table 48 - Dynamic Learning Table Size.....	60
Table 49 - Dynamic Address Age Limit.....	60
Table 50 - Dynamic MAC Table	60
Table 51 - S1 Interface Port Auto-Negotiation.....	61
Table 52 - Port Capabilities	61
Table 53 - Source Address Admission Control	61
Table 54 - MAC Learning Min Guarantee	62
Table 55 - MAC Learning Max Allowed	62
Table 56 - MAC Learning Aggregate Limit.....	62
Table 57 - Len Error Discard.....	62
Table 58 - Flood Unknown.....	63
Table 59 - Local Switching.....	63
Table 60 - LLID and Queue Configuration	63
Table 61 - MAC Table Full Behavior.....	64
Table 62 - Add Dynamic MAC Address	65
Table 63 - Configure eSAFE	65
Table 64 - Enable/Disable eMTA/eDVA	66
Table 65 - Add Static MAC Address.....	67
Table 66 - Delete Static MAC Address	67
Table 67 - Rx Frames Green.....	68
Table 68 - Tx Frames Green.....	68
Table 69 - Rx Frame Too Short.....	68
Table 70 - Rx Frame	68
Table 71 - Rx Frame 65_127	68
Table 72 - Rx Frame 128_255	69
Table 73 - Rx Frame 256_511	69
Table 74 - Rx Frame 512_1023	69
Table 75 - Rx Frame 1024_1518.....	69
Table 76 - Rx Frame 1519 Plus	69
Table 77 - Tx Frame 64.....	70
Table 78 - Tx Frame 65_127	70
Table 79 - Tx Frame 128_255	70
Table 80 - Tx Frame 256_511	70
Table 81 - Tx Frame 512_1023	70
Table 82 - Tx Frame 1024_1518	71
Table 83 - Tx Frame 1519 Plus	71
Table 84 - Queue Delay Threshold.....	71
Table 85 - Queue Delay.....	71
Table 86 - Frames Dropped	72

Table 87 - Bytes Dropped.....	72
Table 88 - Bytes Delayed	72
Table 89 - Tx Bytes Unused.....	72
Table 90 - Optical Mon Temperature	73
Table 91 - Optical Mon Vcc.....	73
Table 92 - Optical Mon Tx Bias Current.....	73
Table 93 - Optical Mon Tx Power	73
Table 94 - Optical Mon Rx Power.....	74
Table 95 - Rx Frames Yellow.....	74
Table 96 - Tx Frames Yellow.....	74
Table 97 - Tx Bytes Green.....	74
Table 98 - Tx Bytes Green.....	75
Table 99 - Tx Bytes Yellow.....	75
Table 100 - Tx Frames Unicast	75
Table 101 - Tx Frames Multicast.....	75
Table 102 - Tx Frames Broadcast.....	75
Table 103 - Rx Frames Unicast	76
Table 104 - Rx Frames Multicast	76
Table 105 - Rx Frames Broadcast	76
Table 106 - L2CP Frames Rx	76
Table 107 - L2CP Octets Rx.....	77
Table 108 - L2CP Frames Tx	77
Table 109 - L2CP Octets Tx.....	77
Table 110 - L2CP Frames Discarded.....	77
Table 111 - L2CP Octets Discarded.....	77
Table 112 - Tx L2 Errors.....	78
Table 113 - Rx L2 Errors.....	78
Table 114 - Port Stat Threshold.....	79
Table 115 - Link Stat Threshold.....	79
Table 116 - Alarm Enable.....	79
Table 117 - Encryption Key Expiry Time	80
Table 118 - Encryption Mode.....	80
Table 119 - Rule Attribute Subtypes	81
Table 120 - Rule Attribute Header Subtype	81
Table 121 - Rule Attribute Clause Subtype	81
Table 122 - Field Codes.....	82
Table 123 - Rule Operators.....	83
Table 124 - Rule Attribute Result Subtype.....	83
Table 125 - Rule Results	84
Table 126 - Set Parameters	85
Table 127 - Copy Parameters	85
Table 128 - Delete Parameters.....	85
Table 129 - Insert Parameters	85
Table 130 - Replace Parameters	86

Table 131 - Clear Delete Parameters	86
Table 132 - Clear Insert Parameters	86
Table 133 - Custom Field	86
Table 134 - Custom Field Layer Values	87
Table 135 - C-VLAN TPID	90
Table 136 - S-VLAN TPID	91
Table 137 - I-TPID	91
Table 138 - B-TPID	91
Table 139 - Broadcast Rate Limit	92
Table 140 - Queue CIR	92
Table 141 - FEC Mode	93
Table 142 - Queue EIR	93
Table 143 - Queue Color Marking	94
Table 144 - Queue Rate Limiter Capabilities	94
Table 145 - Coupling Flag	94
Table 146 - Loopback Enable	95
Table 147 - Loopback Disable	96
Table 148 - Laser Tx Power Off	97
Table 149 - Clock Transport Capabilities	97
Table 150 - Clock Transport Enable	97
Table 151 - Time Transfer	98
Table 152 - Propagation Parameters	98
Table 153 - RTT	98
Table 154 - EEE Status	99
Table 155 - PoE Status	99
Table 156 - Media Type	99
Table 157 - Key Assignment	102
Table 158 - Key Assignment Ack	102
Table 159 - File Transfer PDU Header	103
Table 160 - File Transfer PDU Opcodes	103
Table 161 - File Transfer Write Request	104
Table 162 - File Transfer Data	104
Table 163 - File Transfer Ack	105
Table 164 - File Acknowledgement Response Code	105
Table 165 - [802.3] Clause 30 Attributes (Branch 07)	106
Table 166 - DPoE Attributes (Branch D7)	108
Table 167 - [802.3] Clause 30 Actions (Branch 09)	111

1 INTRODUCTION

DOCSIS Provisioning of EPON (DPoE) version 2.0 specifications are a joint effort of Cable Television Laboratories (CableLabs), cable operators, vendors, and suppliers to support EPON technology using existing DOCSIS-based back-office systems and processes. DPoE v2.0 specifications augment the DPoE v1.0 specifications to provide requirements for additional service capabilities and corresponding provisioning and network management capabilities.

Ethernet PON (EPON) is an [802.3] standard for a passive optical network (PON). A PON is a specific type of multi-access optical network. A multi-access optical network is an optical fiber based network technology that permits more than two network elements to transmit and receive on the same fiber.

DPoE specifications are focused on DOCSIS-based provisioning and operations of Internet Protocol (IP) using DOCSIS Internet service (which is typically referred to as High Speed Data (HSD)), or IP(HSD) for short, and Metro Ethernet services as described by Metro Ethernet Forum (MEF) standards. DPoE Networks offer IP(HSD) services functionally equivalent to DOCSIS networks, where the DPoE System acts like a DOCSIS CMTS and the DPoE System and DPoE Optical Network Unit (ONU) together act like a DOCSIS CM.

1.1 DPoE Technology Introduction¹

DPoE technology was established with the following common requirements already developed by operators. Each of the participant operators had previously selected 1G-EPON and 10G-EPON as the appropriate technology for one or more applications. EPON is a widely-deployed technology with a sufficient and large supply of vendors offering a variety of products for each component of the access network. 2G-EPON, as described Annex A of [DPoE-PHYv2.0], uses the same 1G upstream as 1G-EPON (operates at the effective rate of 1 Gbps), but provides a 2G downstream (operates at the effective rate of 2 Gbps). With the exception of requirements specified in Annex A of [DPoE-PHYv2.0], 2G-EPON is expected to meet all of the requirements specified for 1G-EPON. 10G-EPON technology is now becoming available and is backwards compatible with 1G-EPON. A 1G-EPON network can be incrementally upgraded to 10G-EPON, adding or replacing ONUs as business needs require. 1G-EPON, 2G-EPON, and 10G-EPON are compatible with [SCTE 174].

The EPON protocol [802.3ah] and the amendment for 10G-EPON [802.3av] support a point-to-multipoint architecture with a centralized controller called an Optical Line Terminal (OLT) and distributed low cost Layer 2 ONUs. The basic service mapping architecture in EPON is to map Ethernet (or IP) frame header information (e.g., addresses, IP DiffServ Code Points, Ethernet Q tag, S-VLAN/C-VLAN ID, ISID, bridge address, etc.) to a logical circuit called a Logical Link Identifier (LLID) in [802.3ah]. The service function is similar to that used in DOCSIS networks in many ways because it is based on a centralized scheduler and uses an LLID which functions like an SID, supports both unicast and broadcast, and has other similarities.

Existing [802.3ah] EPON systems do interoperate within the strict definitions of 1G-EPON. Experience with lab testing, field trials, and deployments has shown operators that 1G-EPON OLT and ONU systems typically only interoperate with a single port ONU. This is because [802.3ah] specifies the interfaces on the PON (the DPoE TU interface) but does not specify any of the other system interfaces. For example, an OLT from vendor A will register an ONU from vendor B, but it is not possible to construct a VLAN from the DPoE MN interface to an S interface. This is a well-recognized limitation of [802.3ah]. The challenge is that neither 1G-EPON nor 10G-EPON specify OAMP to forward traffic between Network to Network Interface (NNI) ports (I-NNI for MEF or NSI for L2VPN or IP(HSD)) and the PON, or UNI ports and the PON. This is not different from other Ethernet standards. For example, if two Ethernet switches from two different vendors are connected, each switch must typically be configured independently. The challenge for EPON is that the remote device (the ONU) cannot be reached, and therefore cannot be configured. A solution to this problem must then be based on developing a common (standard) method of reaching the controller for the ONU, identifying the ONU capabilities, and providing that information to the OLT so that it can configure the ONU to forward traffic.

¹ Revised per OAMv2.0-N-14.0188-1 on 7/18/14 by JB.

Even if EPON had solved that provisioning challenge, there are no standard management interfaces for the ongoing operations and maintenance of the network, including fault management, performance management, security, etc. Operators already have fully working and scaled-out systems that solve these challenges for DOCSIS networks. One of the primary goals for DPoE specifications is to use the existing DOCSIS back-office infrastructure to scale up EPON-based business services.

1.2 Scope

Since the vCM operates on the DPoE System (instead of the D-ONU), a means of communication from the vCM to the D-ONU is required. The D-ONU does not require an IP stack. Therefore, [802.3] standard EPON OAM is used for messaging between the vCM on the DPoE System and the D-ONU. The OAM Extensions specified here provide additional means for such messaging for parameters not supported in the [802.3] standard EPON OAM. The [802.3] specifications allow vendor-specific OAM extensions. This document describes the usage of this extension feature to provide for a common set of OAM extensions to support interoperability between all vendors that choose to develop products in accordance with the DPoE specifications.

This document defines the interface used for conveying management information between a DPoE System and D-ONU. This specification defines message format and contents for the following types of configuration or information collection:

- General management and device capabilities
- Forwarding provisioning
- Statistics collection
- Alarm status
- Security key exchange
- Frame processing and classification
- Quality of Service provisioning
- Time Synchronization (ToD, Frequency, and Phase)

Implementations that conform to this specification are required to implement all the features defined in this specification.

Implementations may also implement other [802.3] Clause 57 OAM extensions if desired. DPoE implementations that conform to this specification must fully interoperate with other DPoE implementations that conform to this specification regardless of the presence or absence of other OAM extensions.

1.3 DPoE OAM Specification Goals

The goals of the DPoE OAM Specification are to:

- Provide a common method of managing D-ONUs from different vendors to ensure interoperability;
- Define packet formats and data encodings to support DPoE features;
- Provide a "toolkit" of features from which these DPoE features can be constructed (rather than just assign monolithic blocks of parameters for each feature individually);
- Establish specifications for OAM parameters, behavior, and extended features where such are needed;
- Limit complexity and cost of D-ONU devices by adapting L2 management protocols previously used in EPON.

1.4 Requirements

Throughout this document, the words that are used to define the significance of particular requirements are capitalized. These words are:

"MUST"	This word means that the item is an absolute requirement of this specification.
"MUST NOT"	This phrase means that the item is an absolute prohibition of this specification.
"SHOULD"	This word means that there may exist valid reasons in particular circumstances to ignore this item, but the full implications should be understood and the case carefully weighed before choosing a different course.
"SHOULD NOT"	This phrase means that there may exist valid reasons in particular circumstances when the listed behavior is acceptable or even useful, but the full implications should be understood and the case carefully weighed before implementing any behavior described with this label.
"MAY"	This word means that this item is truly optional. One vendor may choose to include the item because a particular marketplace requires it or because it enhances the product, for example; another vendor may omit the same item.

1.5 DPoE Version 2.0 Specifications

A list of the specifications included in the DPoE 2.0 series is provided in Table 1. For further information please refer to <http://www.cablelabs.com/specs/specification-search/?cat=dpo&scat=dpo-2-0>.

Table 1 - DPoE 2.0 Series of Specifications²

Designation	Title
DPoE-SP-ARCHv2.0	DPoE Architecture Specification
DPoE-SP-OAMv2.0	DPoE OAM Extensions Specification
DPoE-SP-PHYv2.0	DPoE Physical Layer Specification
DPoE-SP-SECv2.0	DPoE Security and Certificate Specification
DPoE-SP-IPNEv2.0	DPoE IP Network Element Requirements
DPoE-SP-MULPIv2.0	DPoE MAC and Upper Layer Protocols Interface Specification
DPoE-SP-MEFv2.0	DPoE Metro Ethernet Forum Specification
DPoE-SP-OSSIV2.0	DPoE Operations and Support System Interface Specification

² Revised per OAMv2.0-15.0229-1 on 2/11/16 by JB. Revised per OAMv2.0-N-15.0239-1 on 6/2/16 by JB.

1.6 Reference Architecture

The DPoE reference architecture identifies the elements that a DPoE Network minimally requires to illustrate and communicate the physical hardware and logical software interfaces between the functional subsystems of the DPoE architecture. The principal elements in the architecture are the DPoE System that resides in the operator network, and the DPoE ONU (D-ONU) which may be an off- the-shelf EPON ONU, EPON SFP-ONU, or an EPON ONU with additional subsystems. The remaining elements in the architecture are existing servers and systems in the operator’s network. All the server elements have connectivity through an IP (TCP/IP) network. Transport of bearer traffic, and (in some cases) Layer 2 OAM Protocol Data Units (PDUs) are available through either IP or Layer 2 Ethernet-based Network Interfaces.

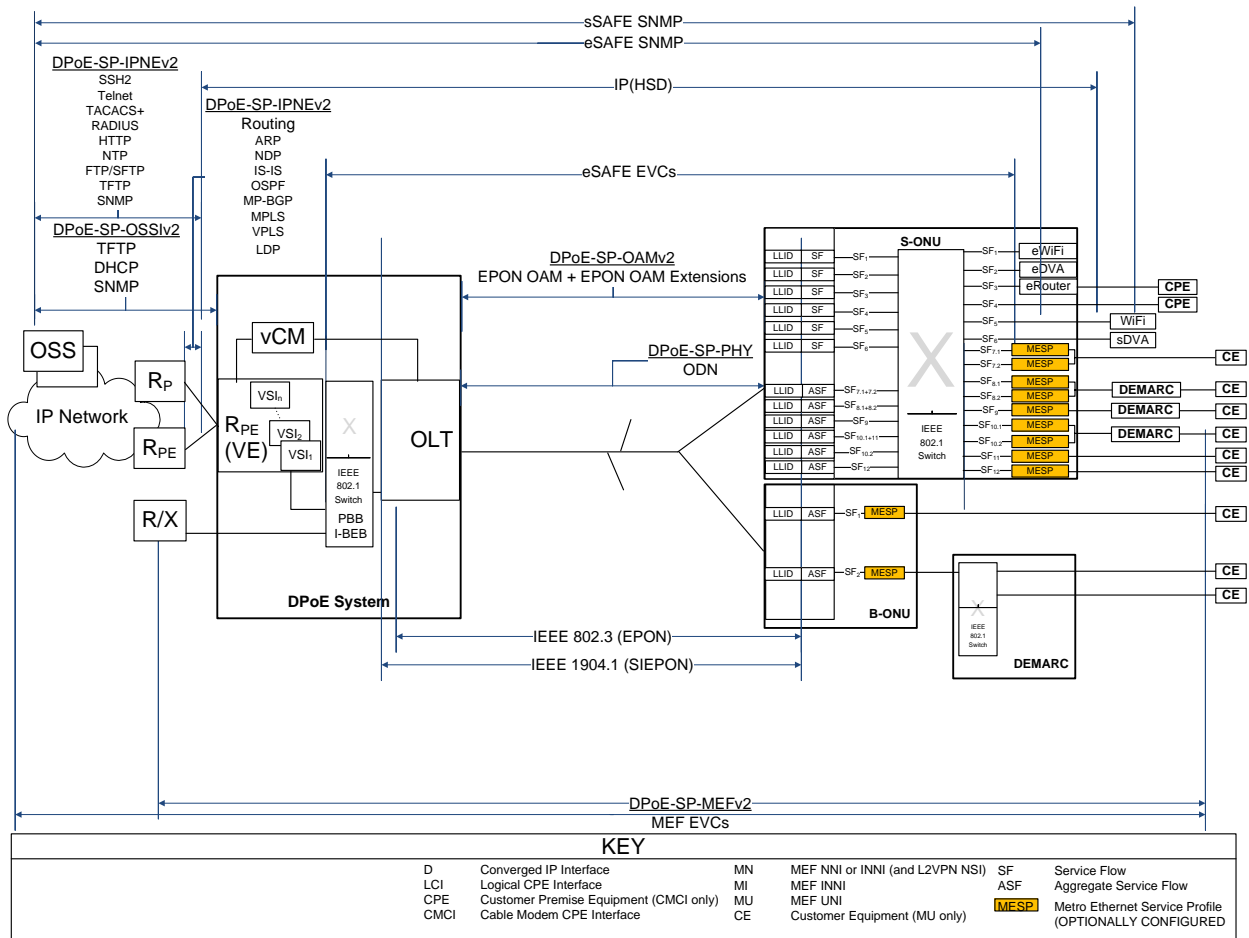

Figure 1 - DPoEv2.0 Reference Architecture³

³ Replaced per OAMv2.0-N-15.0239-1 on 6/2/16 by JB.

1.7 DPoE Interfaces and Reference Points

The DPoE interfaces and reference points provide a basis for the description and enumeration of DPoE specifications for the DPoE architecture. Each interface or reference point indicates a point between separate subsystems. The reference points have protocols that run across them, or have a common format of bearer traffic (with no signaling protocol). All the interfaces are bi-directional interfaces that support two-way communications. The protocols in DPoE specifications operate within different layers based on the [802.3], [802.1], IETF, MEF, and CableLabs specifications. The C reference points are uni-directional for upstream (C_O) or downstream (C_S) classification, respectively.

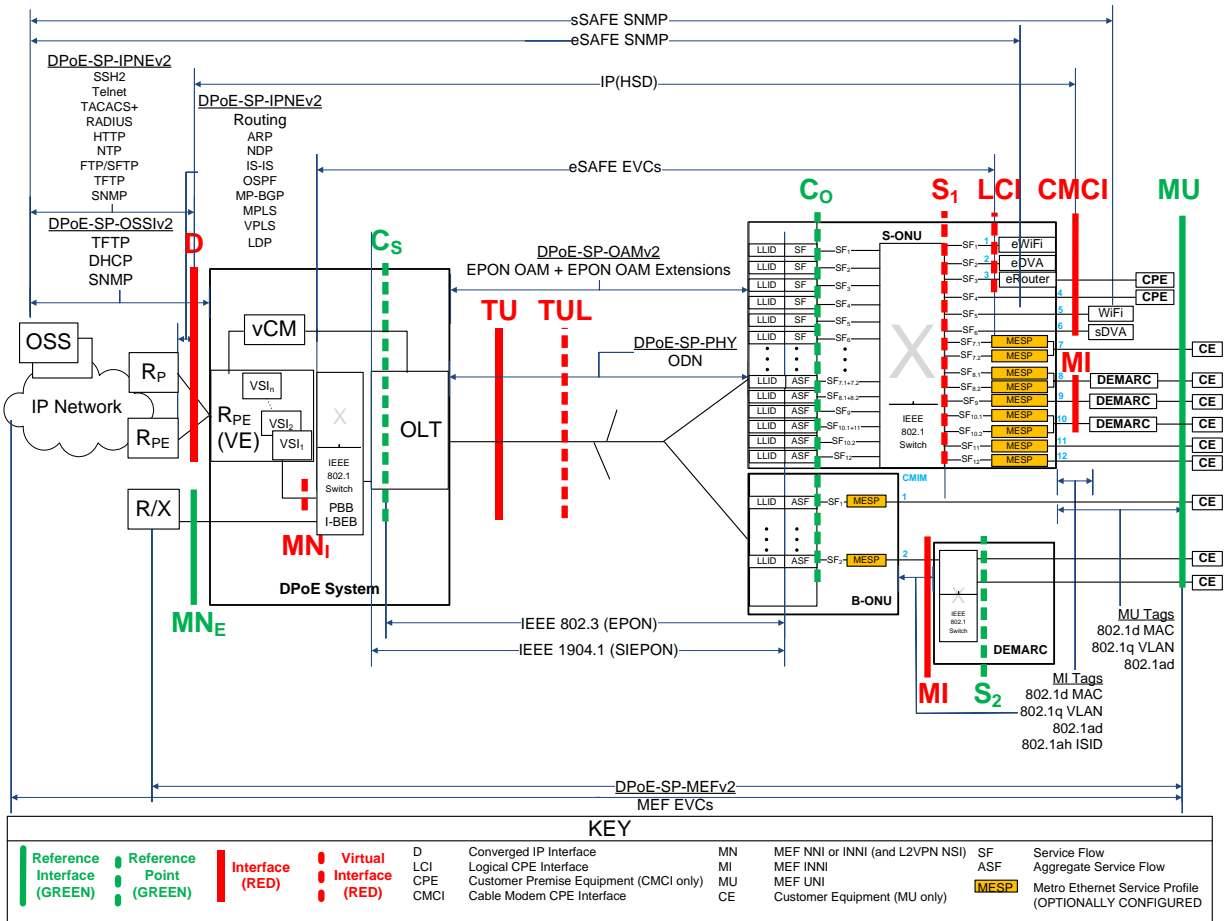

Figure 2 - DPoEv2.0 Interfaces and Reference Points⁴

⁴ Replaced per OAMv2.0-N-15.0239-1 on 6/2/16 by JB.

Table 2 - DPoEv2.0 Interface and Reference Point Descriptions

Interface or Reference Point		Interface or Reference Point Description
MN		MN is a logical concept used for the specification of requirements for MEF INNI that apply to both MN _E and MN _I . MN logically provides the equivalent function of a MEF INNI or L2VPN NSI. It is an NNI for Metro Ethernet services only.
	MN _E	The MN _E (MEF INNI External) interface is a substitute for the MN reference interface from DPoE version 1.0 specifications. The MN interface is an [802.3] interface for Ethernet (or MEF or L2VPN emulated) services only. It serves the role of a MEF INNI or L2VPN NSI. It is an NNI for Metro Ethernet services only.
	MN _I	The MN _I reference interface is used to describe the virtual interface between an OLT and a VPLS Virtual Switch Instance (VSI). In particular, it is used to describe the requirements for stitching VSIs to DPoE System and OLT [802.1] components such as [802.1d] bridge groups, [802.1ad] S-VLAN or C-VLAN (S-component or C-component), or [802.1ad] I-BEB (I-component) or B-BEB (B-component) backbone edge bridges. The DPoE System stitches VPLS and VPWS transport and forwarding for Metro Ethernet Services between the D interface and the MN _I reference interface ⁵ .
D		The D interface is the DOCSIS IP NNI interface. It is an operator network-facing interface, sometimes called a Network Systems Interface (NSI) in DOCSIS specifications. The D interface allows a DPoE System to communicate with an IP network. The D interface carries all IP management traffic including OSSI and IP NE traffic. The D interface carries all DOCSIS IP service traffic, IP/MPLS/VPLS traffic, and IP/MPLS/VPWS traffic.
TU		The TU interface is the interface between the DPoE System and the D-ONU.
TUL		The TUL interface is a virtual interface representing a logical EPON on an ODN. Each ODN has at least one TUL, and each TUL represents a MAC domain.
C		The C reference point is used for explanation of traffic ingress to a DPoE classifier.
	C _O	The C _O reference point is used for explanation of traffic ingress to a D-ONU upstream classifier.
	C _S	The C _S reference point is used for explanation of traffic ingress to a DPoE System downstream classifier.
S		The S interface is an IEEE 802 interface. The S interface may be an internal interface, such as [802.3] across a SERDES (GMII or XGMII) interface in a BP-ONU (such as an SFP-ONU, SFP+ONU or XFP-ONU), or it may be an external Ethernet interface in a BB-ONU or S-ONU. S ₁ is an interface for an S-ONU. S ₂ is a reference point used for explanation of services with the B-ONU.
	S ₁	The S ₁ interfaces are the general case of all interfaces on an S-ONU. S ₁ interfaces may be CMCI, LCI, MI, or MU interfaces.
	S ₂	The S ₂ reference point is used for explanation of traffic ingress to and egress from interfaces on a DEMARC device in a DPoE System. Although there are no specifications or requirements for the S ₂ reference point, informative text refers to the S ₂ reference point to provide the full context for the use of a B-ONU with a DEMARC device providing Metro Ethernet services.

⁵ MN_I is required for IP-based forwarding and transport of Metro Ethernet services with DPoE in order to provide MEF E-LAN and E-TREE services described in DPoE version 2.0. While these services can be constructed with MN_E, these specifications do not describe the process to do so.

Interface or Reference Point	Interface or Reference Point Description
LCI	The Logical CPE Interface (LCI) interface is an eDOCSIS interface as defined in [eDOCSIS]. eSAFEs are connected to LCI interfaces.
CMCI	CMCI is the DPoE interface equivalent of the DOCSIS Cable Modem CPE Interface as defined in [CMCIv3.0]. This is the service interface for DOCSIS-based IP services. Customer Premise Equipment (CPE) is connected to CMCI interfaces.
MI	<p>MI is an S interface that operates as a MEF INNI with additional requirements as specified in [DPoE-MEFv2.0]. The MI interface is an [802.3] interface (or reference point) between a D-ONU and a DEMARC device.</p> <p>A D-ONU that provides a MEF INNI has an MI interface.</p> <p>A D-ONU can have MU as an interface and an MI reference point on different S interfaces in a single D-ONU.</p> <p>DEMARC devices are connected to MI interfaces.</p>
MU	<p>MU is an S interface (or S reference interface) that operates as a MEF UNI. The MU reference interface is an [802.3] interface (or reference point) between a D-ONU or a DEMARC device and a customer's equipment.</p> <p>A D-ONU that directly provides a MEF UNI (MU) interface has MU as an interface.</p> <p>A D-ONU can have MU as an interface and an MI reference point on different S interfaces in a single D-ONU.</p> <p>Customer Edge (CE) devices are connected to MU interfaces.</p>

2 REFERENCES⁶

2.1 Normative References

In order to claim compliance with this specification, it is necessary to conform to the following standards and other works as indicated, in addition to the other requirements of this specification. Notwithstanding, intellectual property rights may be required to use or implement such normative references. At the time of publication, the editions indicated were valid. All references are subject to revision, and users of this document are encouraged to investigate the possibility of applying the most recent editions of the documents listed below. References are either specific (identified by date of publication, edition number, version number, etc.) or non-specific. For a non-specific reference, the latest version applies.

In this specification, terms "802.1ad" and "802.1ah" are used to indicate compliance with the [802.1ad] and [802.1ah] standards, respectively, now incorporated as part of [802.1Q]. For all intents and purposes, claiming compliance to [802.1Q], [802.1ad] or [802.1ah] in the scope of this specification will be treated as claiming compliance to IEEE Std 802.1Q-2011. Unless otherwise stated, claiming compliance to 802.1Q-2005 requires a specific date reference.

[802.1]	Refers to entire suite of IEEE 802.1 standards unless otherwise specified.
[802.1d]	IEEE Std 802.1d™-2004, IEEE Standard for Local and Metropolitan Area Networks: Media Access Control (MAC) Bridges.
[802.1Q]	IEEE Std 802.1Q-2011, IEEE Standard for Local and Metropolitan Area Networks - Media Access Control (MAC) Bridges and Virtual Bridge Local Area Networks, August 2011.
[802.3]	IEEE Std 802.3-2012, IEEE Standard for Ethernet, December 2012
[802.3av]	IEEE Std 802.3av™-2009, IEEE Standard for Information technology-Telecommunications and information systems-Local and metropolitan area networks-Specific requirements, Part 3: Carrier Sense Multiple Access with Collision Detection (CSMA/CD) Access Method and Physical Layer Specifications Amendment 1: Physical Layer Specifications and Management Parameters for 10Gb/s Passive Optical Networks, now part of [802.3].
[1904.1A]	IEEE Std 1904.1™-2016, IEEE Standard for Service Interoperability in Ethernet Passive Optical Networks (SIEPON), Package A, draft D2.0.
[DPoE-ARCHv2.0]	DOCSIS Provisioning of EPON, DPoE Architecture Specification, DPoE-SP-ARCHv2.0-I05-160602, June 2, 2016, Cable Television Laboratories, Inc.
[DPoE-IPNEv2.0]	DOCSIS Provisioning of EPON, IP Network Element Requirements, DPoE-SP-IPNEv2.0-I06-160602, June 2, 2016, Cable Television Laboratories, Inc.
[DPoE-MEFv2.0]	DOCSIS Provisioning of EPON, Metro Ethernet Forum Specification, DPoE-SP-MEFv2.0-I05-170111, January 11, 2017, Cable Television Laboratories, Inc.
[DPoE-MULPIv2.0]	DOCSIS Provisioning of EPON, MAC and Upper Layer Protocols Interface Specification, DPoE-SP-MULPIv2.0-I12-170510, May 10, 2017, Cable Television Laboratories, Inc.
[DPoE-OSSIV2.0]	DOCSIS Provisioning of EPON, Operations and Support System Interface Specification, DPoE-SP-OSSIV2.0-I11-170510, May 10, 2017, Cable Television Laboratories, Inc.
[DPoE-PHYv2.0]	DOCSIS Provisioning of EPON, Physical Layer Specification, DPoE-SP-PHYv2.0-I05-160602, June 2, 2016, Cable Television Laboratories, Inc.

⁶ Revised per OAMv2.0-N014.0173-1 on 7/18/14 by JB. Revised per OAMv2.0-N-14.0199-1 on 11/20/14 by JB. Revised per OAMv2.0-15.0224-1 and OAMv2.0-15.0229-1 on 2/11/16 by JB. Revised per OAMv2.0-N-15.0239-1 on 6/2/16 by JB.

- [DPoE-SECv2.0] DOCSIS Provisioning of EPON, Security and Certificate Specification, DPoE-SP-SECv2.0-I05-160602, June 2, 2016, Cable Television Laboratories, Inc.
- [DPoG-OAM] DOCSIS Provisioning of GPON, DPoG OAM Extensions Specification. DPoG-SP-OAMv1.0-C01-160830, August 30, 2016, Cable Television Laboratories, Inc.

2.2 Informative References⁷

This specification uses the following informative references.

- [1588v2] IEEE Std 1588-2008, IEEE Standard for a Precision Clock Synchronization Protocol for Networked Measurement and Control Systems, July 2008.
- [802.1ad] IEEE Std 802.1adTM-2005, IEEE Standard for Local and Metropolitan Area Networks – Virtual Bridged Local Area Networks Amendment 4: Provider Bridges, May 2006. Former amendment to 802.1Q, now part of 802.1Q-2011.
- [802.1ag] IEEE Std 802.1ag-2007, IEEE Standard for Local and Metropolitan Area Networks – Virtual Bridged Local Area Networks Amendment 5: Connectivity Fault Management, December 2007.
- [802.1ah] IEEE Std 802.1ah-2008, IEEE Standard for Local and Metropolitan Area Networks – Virtual Bridged Local Area Networks – Amendment 6: Provider Backbone Bridges, January 2008. Former amendment to 802.1Q, now part of 802.1Q-2011.
- [802.3ah] IEEE Std 802.3ahTM-2004, IEEE Standard for Information technology-Telecommunications and information systems-Local and metropolitan area networks-Specific requirements, Part 3: Carrier Sense Multiple Access with Collision Detection (CSMA/CD) Access Method and Physical Layer Specifications, Amendment: Media Access Control Parameters, Physical Layers, and Management Parameters for Subscriber Access Networks, now part of [802.3].
- [CMCIv3.0] Data-Over-Cable Service Interface Specifications, Cable Modem to Customer Premise Equipment Interface Specification, CM-SP-CMCIv3.0-I03-170510, May 10, 2017, Cable Television Laboratories, Inc.
- [DOCSIS] Refers to entire suite of DOCSIS 3.0 specifications unless otherwise specified.
- [eDOCSIS] Data-Over-Cable Service Interface Specifications, eDOCSIS Specification, CM-SP-eDOCSIS-I28-150503, May 3, 2015, Cable Television Laboratories, Inc.
- [MULPIv3.0] Data-Over-Cable Service Interface Specifications, MAC and Upper Layer Protocols Interface Specification, CM-SP-MULPIv3.0-I30-170111, January 11, 2017, Cable Television Laboratories, Inc.
- [OSSIV3.0] Data-Over-Cable Service Interface Specifications, Operations Support System Interface Specification, CM-SP-OSSIV3.0-I30-170111, January 11, 2017, Cable Television Laboratories, Inc.
- [PHYv3.0] Data-Over-Cable Service Interface Specifications, Physical Layer Specification, CM-SP-PHYv3.0-I13-170111, January 11, 2017, Cable Television Laboratories, Inc.
- [RFC 5462] IETF RFC 5462, Multiprotocol Label Switching (MPLS) Label Stack Entry: "EXP" Field Renamed to "Traffic Class" Field, L. Andersson, R. Asati, February 2009.
- [SCTE 174] ANSI/SCTE 174 2010, Radio Frequency over Glass Fiber-to-the-Home Specification.
- [SECv3.0] Data-Over-Cable Service Interface Specifications, Security Specification, CM-SP-SECv3.0-I16-160602, June 2, 2016, Cable Television Laboratories, Inc.

⁷ Revised per OAMv2.0-15.0224-1 and OAMv2.0-15.0229-1 on 2/11/16 by JB.

- [SFF-8077i] SFF-8077i 10 Gigabit Small Form Factor Pluggable Module, Revision 4.5, released April 13, 2004.
- [SFF-8472] SFF-8472 Specification for Diagnostic Monitoring Interface for Optical Transceivers, Revision 10.4, released January 2009.
- [SFP MSA] INF 8074i Rev 1.0, Small Form-factor Pluggable Multi-Source Agreement, released May 2001.

2.3 Reference Acquisition

- Cable Television Laboratories, Inc., 858 Coal Creek Circle, Louisville, CO 80027; Phone +1-303-661-9100; Fax +1-303-661-9199; <http://www.cablelabs.com>
- Internet Engineering Task Force (IETF) Secretariat, 48377 Fremont Blvd., Suite 117, Fremont, California 94538, USA, Phone: +1-510-492-4080, Fax: +1-510-492-4001, <http://www.ietf.org>
- Institute of Electrical and Electronics Engineers (IEEE), +1 800 422 4633 (USA and Canada); <http://www.ieee.org>
- SCTE, Society of Cable Telecommunications Engineers Inc., 140 Philips Road, Exton, PA 19341 Phone: +1-800-542-5040, Fax: +1-610-363-5898, Internet: <http://www.scte.org/>
- Small Form Factor Committee (SFF), <http://www.sffcommittee.com>

3 TERMS AND DEFINITIONS

3.1 DPoE Network Elements

DPoE Network	This term means all the elements of a DPoE implementation, including at least one DPoE System, and one or more D-ONUs connected to that DPoE System.
DPoE System	This term refers to the set of subsystems within the hub site that provides the functions necessary to meet DPoE specification requirements.
DPoE ONU (D-ONU)	This term means a DPoE-capable ONU that complies with all the DPoE specifications. There are two logical types of D-ONUs. These are the DPoE Standalone ONU (S-ONU) and the DPoE Bridge ONU (B-ONU). Requirements specified for a D-ONU must be met by all ONUs.
DPoE Standalone ONU (S-ONU)	This term means a D-ONU that provides all the functions of a B-ONU and also provides at least one CMCI port. An S-ONU can optionally have one or more eSAFES.
DPoE Bridge ONU (B-ONU)	This term means a D-ONU that is capable of [802.1] forwarding but cannot do all the encapsulation functions required to be an S-ONU. The B-ONU is a logical definition used by the specification for requirements that apply to all types of B-ONUs. The two types of B-ONUs are the BP-ONU and the BB-ONU.
DPoE Bridge Pluggable ONU (BP-ONU)	This term means a D-ONU that is a B-ONU which is pluggable. Pluggable BP-ONUs include devices such as an SFP-ONU (1G-EPON), SFP+ONU (10G-EPON), or XFP-ONU (10G-EPON).
DPoE Bridge Baseband ONU (BB-ONU)	This term means a D-ONU that is a B-ONU which has a baseband IEEE Ethernet interface. BB-ONUs include those with one or more [802.3] baseband PMDs. (See [DPoE-ARCHv2.0], section 7.2.6.2 for examples.)
DEMARC	Short form of "Demarcation Device." This term means the device, owned and operated by the operator that provides the demarcation (sometimes called the UNI interface) to the customer. Some architectures describe this device as the CPE (as in DOCSIS) or the NID (as in the MEF model).

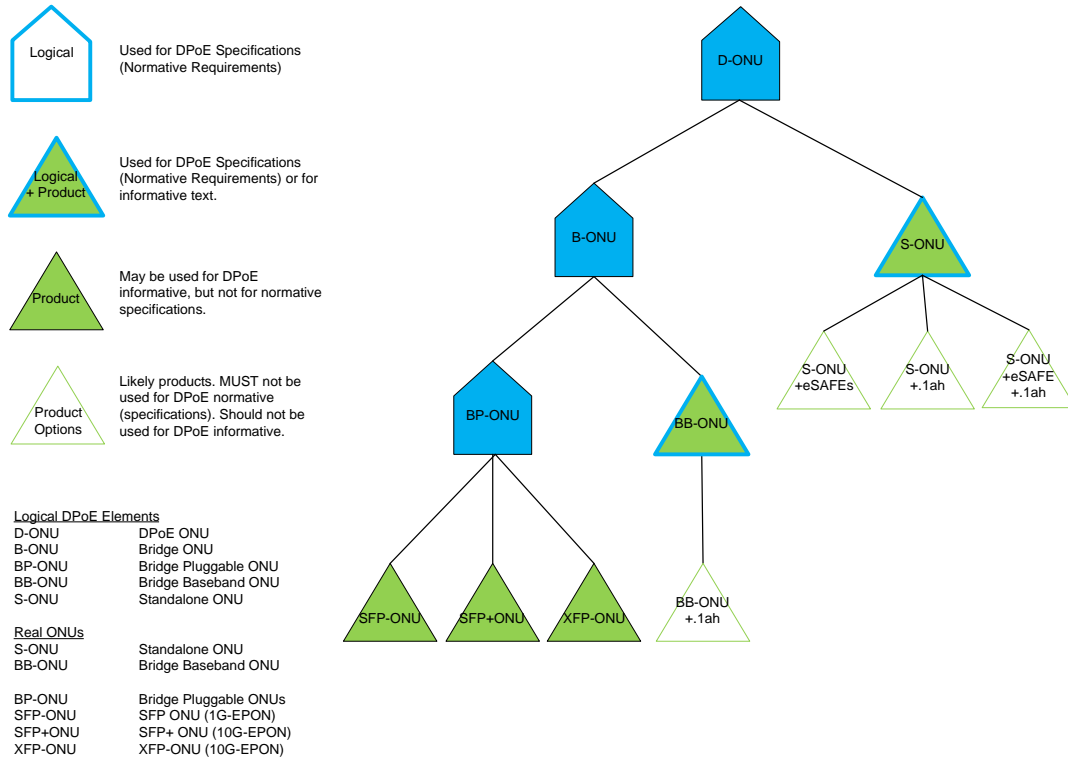

Figure 3 - D-ONU Types

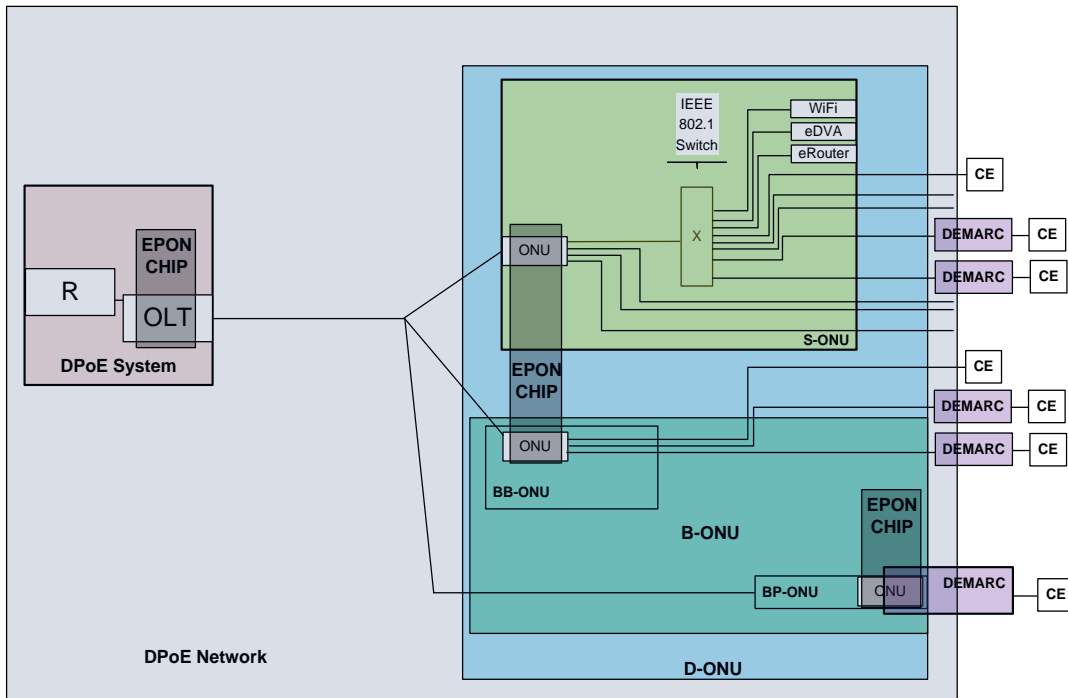

Figure 4 - DPoE Network Elements

3.2 Other Terms⁸

1G-EPON	EPON as first defined in [802.3ah], now part of [802.3]
2G-EPON	EPON as defined in Annex A 2G-EPON System Definition of [DPoE-PHYv2.0]
10G-EPON	EPON as first defined in [802.3av], now part of [802.3]
Cable Modem CPE Interface	CMCI as defined in [MULPIv3.0]
Customer Premise Equipment (CPE)	Customer Premise Equipment as defined in [DOCSIS]
Multi-Layer Switching (MLS)	A switch that can switch based on Layer 2, Layer 3, Layer 4, etc.
Ethernet Passive Optical Network (EPON)	Refers to 1G-EPON, 2G-DPON, and 10G-EPON collectively
EPON Operations and Maintenance Messaging (OAM)	EPON OAM messaging as defined in [802.3] and this document; Ethernet OAM is not the same as EPON OAM; Ethernet OAM is defined in [802.1ag]
Logical CPE Interface	LCI as defined in [eDOCSIS]
Network Interface Device (NID)	A DEMARC device in DPoE specifications

⁸ Revised per OAMv2.0-N014.0173-1 and OAMv2.0-N-14.0188-1 on 7/18/14 by JB.

4 ABBREVIATIONS AND ACRONYMS

This specification uses the following abbreviations:

ACL	Access Control List
ARP	Address Resolution Protocol
BCD	Binary Coded Decimal
CDR	Clock and Data Recovery
CFI	Canonical Format Indicator (in IEEE 802.1Q tag)
CMCI	Cable Modem CPE Interface
CoS	Class of Service
CPE	Customer Premise Equipment
CRC	Cyclic Redundancy Check
D-ONU	DPoE ONU
DHCP	Dynamic Host Configuration Protocol
DIA	Dedicated Internet Access
DoS	Denial of Service
DPoE	DOCSIS Provisioning of EPON
DR	Default Router
DSx	Digital Signal (DS1 or DS3)
eCM	embedded Cable Modem
eDVA	embedded Digital Voice Adapter
ENNI	External Network to Network Interface
EPL	Ethernet Private Line
EPON	Ethernet Passive Optical Network
EP-VLAN	Ethernet Private Virtual Local Area Network
eSAFE	embedded Service/Application Functional Entity
ESP	Ethernet Service Path
EVC	Ethernet Virtual Connection
E-VPL	Ethernet Virtual Private Line
EVP-LAN	Ethernet Virtual Private LAN
FEC	Forward error correction
GBd	Gigabaud
Gbps	Gigabits per second (as used in the industry)
HSD	High Speed Data
IGMP	Internet Group Management Protocol
INNI	Internal Network to Network Interface
IP	Internet Protocol

IP(HSD)	High Speed Data (Broadband Internet Access using DOCSIS)
IPMC	IP MultiCast
I-SID	[802.1ah] I-Component Service IDentifier
LCI	Logical CPE Interface
LLID	Logical Link IDentifier
LSE	Label Stacking Entry
LOS	Loss Of Signal
MAC	Media Access Control
MPCPDU	Multi-Point Control Protocol Data Unit
MEF	Metro Ethernet Forum
MI	MEF INNI Interface at a customer premise
MN	MEF INNI Interface to operators MEN
MPCP	Multi-Point Control Protocol
MTU	Maximum Transmission Unit
MU	MEF UNI Interface
NID	Network Interface Device
NNI	Network to Network Interface
NVS	Non-volatile Storage
OAM	EPON Operations Administration and Maintenance
ODN	Optical Distribution Network
OLT	Optical Line Termination
ONU	Optical Network Unit
OSC	Optical Splitter Combiner
OUI	Organizationally Unique Identifier
PDU	Protocol Data Unit
PHY	Physical Layer
PON	Passive Optical Network
R	IP Router
RARP	Reverse ARP
RTT	Round Trip Time
S-OAM	Ethernet Service OAM
SA	Source Address
SFP	Small Form-factor Pluggable
SFP+	Small Form-factor Pluggable Plus (+)
TLV	Type-Length-Value
TPID	Tag Protocol Identifier
TU	Interface between DPoE System and D-ONU, roughly "the PON fiber"

UNI	User Network Interface
vCM	Virtual Cable Modem
VID	VLAN Identifier
VLAN	Virtual Local Area Network
WSC	Wireless Switching Center
X	IEEE Ethernet Switch (Generic)
XFP	X Form-factor Pluggable

5 BACKGROUND

5.1 IEEE 802 Link OAM for EPON

Traditional network management architecture requires the ONU to support the appropriate network management protocol or protocols. The protocol is usually SNMP, and hence would require IP layer connectivity. This requirement can result in extensive network maintenance to support every ONU on the management network at layer 3. An IP address would be assigned on the service provider's management network to each connected ONU, and ARP/RARP/DHCP issues must be addressed, as well as L3 security over the management channel. L3 management also places a larger burden on the ONU software stack, resulting in greater cost in the high-volume components of the network. The DPoE management architecture terminates network-side management protocols at the DPoE System, carrying out management functions over the TU interface using OAM. By re-using the [802.3] Clause 57 OAM packet format in DPoE specifications, the DPoE ONU (D-ONU) does not need to support additional protocol families for every possible management protocol, simplifying implementation and limiting interoperability problems.

Since [802.3] is a MAC layer standard, Clause 57 OAM messages for Ethernet links are confined in scope of control to the lower half of the data link layer. This is problematic for managing a full network, as a practical EPON ONU will likely serve as an Ethernet bridge and will have remote ports used to connect a customer LAN to EPON. Service providers running EPON need to remotely manage the entire ONU, and not just the EPON MAC. This exactly matches the requirements of the DPoE Network.

DPoE Link OAM should not be confused with Ethernet Service OAM (S-OAM). In DPoE specifications, Link OAM Protocol Data Units (PDUs), as defined in this specification, exist only on the PON. Furthermore, DPoE Link OAM PDUs are defined only for communication between a DPoE System and D-ONU. S-OAM, on the other hand, typically comprises both Performance Management and Fault Management functionality, and S-OAM PDUs can be forwarded to neighboring Ethernet networks toward a destination on a different network.

The IEEE provides a standard mechanism for extending [802.3] Clause 57 OAM, allowing other organizations to define specific extensions. One PDU opcode (0xFE) is reserved for such extensions. Also, organization-specific Type-Length-Value (TLVs⁹) encodings can be added to some standard [802.3] Clause 57 PDUs. The organization defining the extension is identified by an IEEE OUI following the PDU extension opcode or TLV type. The remainder of the PDU format is then defined by the organization identified by the OUI for the frame. This document defines the format used for extensions under the DPoE OUI 0x001000.

Another advantage to extending the [802.3] Clause 57 OAM protocol is its inherent increased security. Without the extensions, an ONU functioning at L3 as a typical SNMP-managed device would extend the service provider's management network to the customer LAN. This creates potential security problems, especially with the open character of SNMP, where users could potentially gain access to the operator's management channels. Per [802.1d], [802.3] Clause 57 OAM cannot be forwarded by a bridge, and so use of this protocol keeps the service provider's management network on the network side of the ONU and insulated from the subscriber interfaces. They also isolate the L3 user data network from the management network at a L2 protocol level, providing increased security over the management channel.

5.2 [802.3] Clause 57 OAM PDUs

The standard [802.3] Clause 57 PDUs are reviewed in the following sections. All OAM messages have a common header format, with EtherType 0x8809, Subtype 0x03, a Flags field that carries information about OAM state, and an opcode that defines the type of PDU. The body of each PDU depends on the opcode.

⁹ TLVs are used to encode information in many data communications protocols. TLVs in this document are specific to DPoE OAM and should not be confused with other uses of TLVs in other DPoE specifications.

Table 3 - IEEE Link OAM Messages Format

Width (Octets)	Field	Value (hex)
6	Ethernet DA (Destination Address)	0x01:80:C2:00:00:02 ([802.3] OAM multicast address)
6	Ethernet SA (Source Address)	As per sending MAC
2	EtherType	0x8809 (Ethernet Slow Protocol)
1	Subtype	0x03 ([802.3] OAM)
2	Flags	As per [802.3]
1	PDU Type	See Table 4
Varies	Data/Pad	As defined for the Opcode. Pad in OAM frames must be zero per [802.3].
4	FCS	Standard FCS generated by the [802.3] MAC

Table 4 - [802.3] Clause 57 PDU Types

IEEE Info TLV Type	Value (hex)
Information	0x00
Event Notification	0x01
Variable Request	0x02
Variable Response	0x03
Loopback Control	0x04
Reserved	0x05..0xFD
Organization Specific	0xFE
Reserved	0xFF

5.2.1 Info PDU

The Info PDU, defined in [802.3] Clause 57.4.3.1, is primarily used during the OAM Discovery phase just after a link is established, in which the OAM peers discover each other's existence and negotiate the maximum OAM frame length. Info PDUs are also periodically transmitted (once per second) as a keep-alive heartbeat for the OAM layer.

The contents of an Info PDU are a series of TLVs. [802.3] Clause 57 defines three TLV types. "Local" and "Remote" information TLVs are always present in an Info PDU, and convey basic information about the OAM channel state. [802.3] Clause 57 also defines a TLV type for an Organization-Specific TLV, which contains an OUI to denote the particular organization which defines the contents of that TLV. DPoE OAM defines an Info TLV type.

Table 5 - [802.3] Info TLV

Width (Octets)	Field	Value (hex)
1	TLV Type	See Table 6
1	Length	Includes Type and Length fields, plus data to follow
Varies	Depends on TLV Type	Depends on TLV Type

Table 6 - [802.3] Info TLV Types

[802.3] Info TLV Type	Value (hex)
End of TLV marker	0x00
Local Information	0x01
Remote Information	0x02
Reserved	0x03..0xFD
Organization-Specific	0xFE
Reserved	0xFF

5.2.2 Event Notification PDU

The [802.3] Clause 57 Event Notification PDU is used to indicate the occurrence of events at one end of a link to the peer at the other end. Typically this is "alarm" information sent from the D-ONU to the DPoE System. Event notification PDUs are not intended to function as an OSS system but to provide the ability for a D-ONU to give notice of specific events to a DPoE System. The use and distribution of this information is managed and forwarded by a DPoE System as prescribed in [DPoE-OSSv2.0]. The Event Notification PDU format, like the Info PDU format, contains a series of Link Event TLVs. [802.3] Clause 57 defines five types of Link Event TLV. The first four are variations on the theme of reporting link fault counts (where a link fault is any of several errors that can occur in an Ethernet, such as CRC errors or frame length errors). The fifth type is reserved for organization-specific TLVs. The DPoE specification defines an extended alarm TLV type used in this PDU to convey more detailed alarm information.

Recall that all OAM frames carry three bits in the standard OAM header which indicate "link fault", "critical event", and "dying gasp" conditions at the sender. The [802.3] Clause 57 Event Notification PDU, as an OAM PDU, contains these bits, but also contains TLVs that provide more detailed information about the conditions that are present.

Table 7 - [802.3] Event Notification TLV

Width (Octets)	Field	Value (hex)
1	TLV Type	See Table 8
1	Length	Includes Type and Length fields, plus data to follow
Varies	Depends on TLV Type	Depends on TLV Type

Table 8 - [802.3] Link Event TLV Types

[802.3] Link Event TLV Type	Value (hex)
End of TLV Marker	0x00
Errored Symbol Period Event	0x01
Errored Frame Event	0x02
Errored Frame Period Event	0x03
Errored Frame Seconds Summary	0x04
Reserved	0x05..0xFD
Organization-Specific	0xFE
Reserved	0xFF

5.2.3 Variable Request/Response PDUs

The Variable Request PDU is the means by which an OAM peer can query the attributes defined in [802.3] Clause 30, which are typically frame counters and error counters, along with basic control state of the MAC layer, such as link status or auto-negotiation results. The Variable Response PDU contains data in response to these requests. Note that in the standard protocol, all attributes are read-only. That is, the Variable Request message can retrieve values, but cannot set them.

The Variable Request PDU consists of a series of "Variable Descriptors" that identify the particular attribute to be retrieved. A Variable Descriptor is composed of "branch" and "leaf" codes that uniquely identify the attribute, at least within the IEEE-controlled numbering space. The Variable Descriptor is essentially a compound, three-byte attribute type code.

The Variable Response PDU consists of a number of Variable Containers. A Variable Container begins with a Variable Descriptor, which is followed by a Length field and then data that indicates the value of the attribute. Thus, the Variable Container is a kind of Type-Length-Value (TLV) format, where the Type is a three-byte code, and reserved values in the Length field serve as error codes.

For compatibility with standard PDUs and attribute numbering, DPoE OAM reuses these structures in its Get and Set PDU types. The contents of these standard PDUs are legal contents for the body of DPoE Get and Get Response PDUs, although they are a subset of the possible legal responses. In this document, Variable Descriptors and Variable Containers will often be referred to simply as "TLVs".

DPoE OAM implementations must not generate such requests with the optional "package" format, as opposed to individual attributes. DPoE OAM implementations need not support the package format requests and responses.

5.2.4 Loopback Control PDU

The [802.3] Clause 57 Loopback PDU is used to put an individual logical link into a loopback state for testing purposes. The Info PDU is also used as a response when establishing or tearing down a loopback, as it carries state information that is useful during the transitions.

5.2.5 Organization-specific PDU

The [802.3] Clause 57 OAM PDU opcode 0xFE is defined to indicate an Organization-specific PDU. The contents of an Organization-specific PDU are defined by the organization indicated by the OUI in this PDU. DPoE OAM makes use of this feature to add many extended features to the basic IEEE logical link management. This document contains the definition for the format of data in organization-specific PDUs and TLVs marked by the DPoE OUI 0x001000.

In general, an EPON ONU may support many organization-specific OAM message sets. Behavior and requirements of other OAM extension sets are outside the scope of this document.

D-ONUs MAY support OAM extensions in addition to DPoE OAM. DPoE Systems MUST NOT require support for non-DPoE extensions. Similarly, D-ONUs MUST NOT require support for non-DPoE extensions. D-ONUs that support message sets other than DPoE extensions MUST NOT be deregistered simply for that reason. Similarly, D-ONUs MUST NOT fail to register with a DPoE System that supports DPoE OAM, even if that DPoE System lacks support for some other OAM message set that the D-ONU would like to use.

A DPoE System MUST NOT allow ONUs that do not support DPoE OAM to register as D-ONUs.

5.3 D-ONU Model

For management purposes, a D-ONU is considered to have the logical structure depicted below.

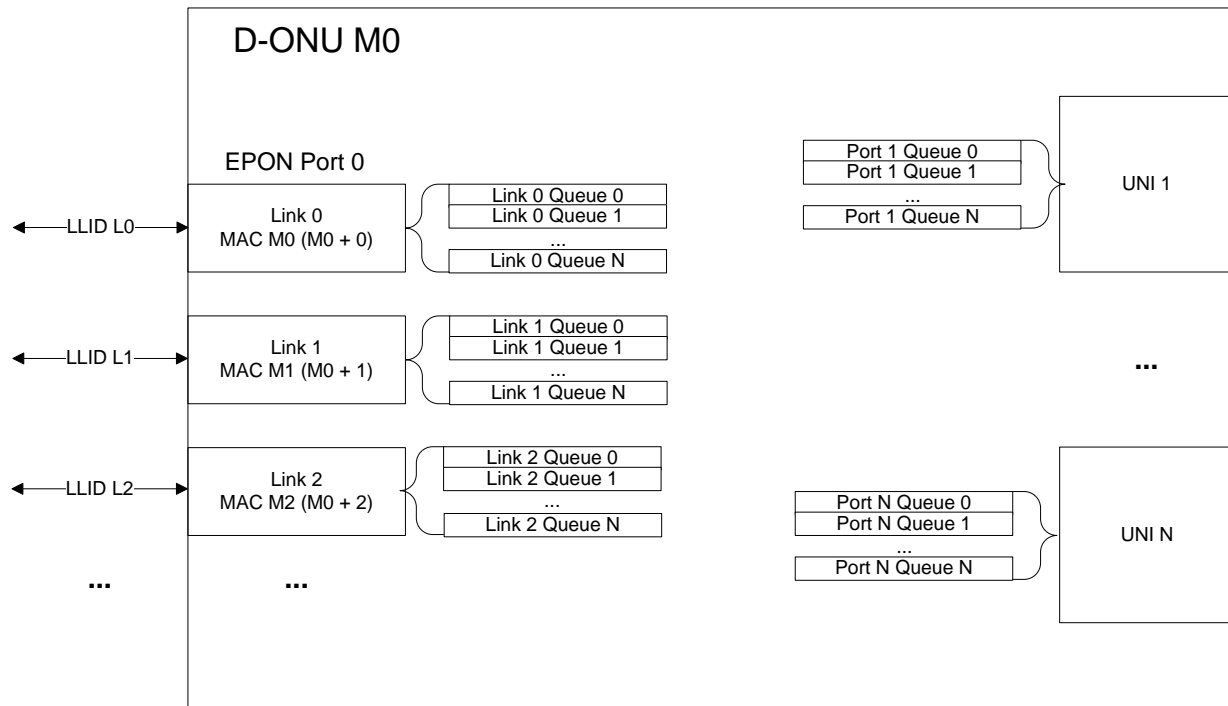

Figure 5 - D-ONU Model

A D-ONU is a device that has one or more MAC interfaces per TU interface (logical links, or just links for short), and one or more MAC interfaces on the user side (DPoE S interfaces or reference points). A switch connects the ports to transfer frames between individual MACs.

The TU interface is a single physical port shared by several MACs, each with an associated Logical Link, whereas the S interfaces (or reference points) usually have one MAC per physical port. Each of these MACs is fed by one or more priority queues. These ports, links, and queues each have OAM attributes that allow remote management.

In addition to the bidirectional (transmit/receive) links shown, D-ONUs support one or more receive-only links. Such links are used to flood traffic downstream on the PON, including unknown MAC addresses for [802.1d] bridging or true Ethernet multicast.

5.4 Frame Processing

Frame processing refers to the configuration of a D-ONU to implement frame forwarding as specified in [DPoE-MEFv2.0] and [DPoE-MULPIv2.0]. Frame processing is performed to accomplish tasks such as classification in which the relative priority of a frame is determined, usually by inspecting fields within the frame, filtering frames (discarding frames with undesirable characteristics), access control (forwarding frames with desirable characteristics), or frame modification, such as adding, removing, or modifying Ethernet tags (including, for example, Tag Protocol Identifiers (TPIDs), VLAN identifiers, priority values) in a frame.

For the purpose of describing this behavior, the DPoE OAM specification (this document) adopts an abstract model of D-ONU behavior. The DPoE OAM messages define frame processing in terms of rules that match fields in a frame, and if the fields match the given values, apply a particular result to the frame. The rule results can forward or discard a frame, set a destination queue, or change the frame by adding or deleting fields. D-ONU software parses these rules and programs the D-ONU implementation-specific hardware to achieve the specified effect.

Using these rules as primitives, it is possible to construct many features. For example, an Access Control List (ACL) is a list of rules that matches MAC or IP source addresses and forward-matching frames. Traffic classification is a matter of matching frames and forwarding the frame into an appropriate priority queue based on the frame contents. Adding an Ethernet tag might be unconditional, as in the case of a VLAN tag for a port, or the tag value might be based on other attributes of the frame to tag frames according to protocol type. Rather than specify distinct OAM messages for all these features, a primitive-oriented approach is used to permit construction of additional features in the future with no additional DPoE OAM message definitions required.

It is not expected that D-ONU hardware processes these rules in software or exactly in the format presented. To be compliant with this specification, any hardware or software implementation may be used, but the DPoE System MUST implement the DPoE eOAM rule set defined in this specification. Similarly, D-ONU MUST also implement the DPoE eOAM rule set defined in this specification.¹⁰

Conceptually, these packet processing rules are applied to frames as they enter ports, whether the TU interface port in the downstream or a User Network Interface (UNI) port in the upstream. For consistency, the field values as used in the rule conditions are always the values in the frame as it enters the port. Any changes to the frame from rule results are considered not to take effect until frame processing has been completed. Thus, the effect of a rule set does not depend on the order of the rules in that set.

All the rules in a port ingress rule table are applied to each frame that enters the port. The results of all rules that match are applied to the frame.

To resolve ambiguity when more than one rule or contradictory rules match the same frame, each rule is associated with a precedence value. The result is that only the highest precedence rule that matches a frame and has a particular result will be applied. Thus, for example, by using two precedence levels, it is possible to establish a single rule that provides a classification for a frame and then override that classification by matching specific control fields with a higher precedence rule (as with DOCSIS classifiers that select traffic into Secondary Service Flows). The precedence of one type of rule result (say, modifying an output field) does not conflict with the precedence of other types of result (say, forwarding the frame, or setting an output queue).

¹⁰ Revised per OAMv2.0-N-13.0077-1 on 6/17/13 by JB.

6 OAM OPERATION

6.1 OAM Discovery

The OAM discovery process defined in [802.3] has a state machine for a certain progression of OAM discovery state bits in the header for OAM messages. OAM is considered an optional feature of [802.3], but support for DPoE OAM is mandatory for all D-ONUs conforming to this standard. A D-ONU that does not actually complete OAM Discovery in a stable state, as per this standard, **MUST** be deregistered by the DPoE System after 5 seconds of attempting OAM discovery, measured from the initial OAM Info PDU sent by the OLT.

During OAM discovery, support for DPoE extensions is declared by adding an Info TLV to the Info PDUs exchanged with the DPoE System as defined in Section 5.2.1. Presence of this DPoE extension support TLV is a declaration of willingness to adhere to the requirements of the DPoE OAM extension set, including the rules on critical OAM and D-ONU behavior in this section. Lack of this TLV means that the ONU is not capable of supporting DPoE extensions, and subsequently will not be allowed to register as a D-ONU.

A D-ONU **MUST** include the DPoE OAM Support Info TLV in all OAM Info frames exchanged during the OAM Discovery phase. The D-ONU **SHOULD NOT** insert this TLV into keep-alive Info frames after OAM Discovery has completed.

6.2 OAM Timeout

To relieve the protocol of complexity in handling out-of-order requests and overall pacing for different D-ONUs, a DPoE System may have only one outstanding OAM request per logical link at any given time. The D-ONU must reply, or the OAM timer expire, before the DPoE System can send another OAM PDU to the D-ONU.

Unless otherwise specified, a D-ONU **MUST** respond to an OAM request from a DPoE System within one second.

If a D-ONU cannot respond before the OAM timeout, it **MUST** raise the D-ONU busy alarm. Failure to respond to OAM results in an error at the DPoE System; handling of this error is implementation-specific, but **MUST NOT** include deregistering the D-ONU. The exception to this rule is "critical" OAM. Failure to respond to critical OAM is a reason to deregister a D-ONU.

6.3 Critical OAM¹¹

Of the hundreds of messages and attributes in the DPoE OAM extension set, a few are deemed "critical" OAM. A successful response to these OAM messages is necessary for the network to work properly. An ONU that does not acknowledge these critical OAM commands is not operating correctly (by definition) and will be deregistered by the DPoE System. These critical OAM commands are required as part of the claim of support for DPoE extensions. An ONU that claims support for DPoE extensions is also promising to respond to these OAM commands in particular, as well as others in this document.

Critical OAM messages are sent immediately after link registration, and may also occur at other times during the D-ONU operation.

Table 9 - Critical OAM Attributes

Attribute	Description	Value (hex)
Device ID	Unique physical device identification number	0xD7/0x0002
Max Number Of Logical Links	Maximum number of logical links (bidirectional LLIDs) supported on the ONU	0xD7/0x0007
ONU Report Thresholds	Controls format of MPCP REPORT PDU	0xD7/0x000B
Set OAM Rate	Changes maximum allowed OAM PDU rate	0xD7/0x000D

The critical OAM messages are described in detail below.

¹¹ Revised per OAMv2.0-N-14.0192-1 on 7/18/14 by JB.

6.3.1 D-ONU Capabilities¹²

Most of the information in the Extended Info PDU is primarily of interest to the network management system. However, a few of these attributes are snooped by DPoE System firmware, and are necessary for the DPoE System to manage D-ONUs.

The D-ONU base MAC address is considered to be the Device ID that ties multiple logical links on the same D-ONU physical device. Similarly, the number of links is necessary for a DPoE System to correctly manage D-ONUs of different configurations.

If a D-ONU does not positively acknowledge these attributes, it cannot be tracked and managed by the DPoE System, and so is deregistered to deny its entry into the DPoE Network.

6.3.2 Set D-ONU Report Threshold

The report threshold limits the size of the frame boundary that is reported to the DPoE System. A DPoE System scheduler generally has some maximum size it is willing to grant (the DBA token size) in order to maintain service guarantees on the PON. If the D-ONU report threshold exceeds this maximum size, then the D-ONU will report a frame boundary larger than the DPoE System can grant. In the best case, EPON efficiency is lost due to loss of frame alignment with the D-ONU, as the DPoE System limits the grant to the maximum size. The next worst effect is that SLAs cannot be correctly enforced, if the DPoE System attempts to grant to the reported frame boundary despite the fact that it is too large given the current demands on the network.

When increasing bandwidth limits, the DPoE System must first increase the OLT token size, and only then increase the D-ONU threshold. Conversely, to decrease the bandwidth limits, the D-ONU report threshold must be lowered before the OLT token size can be decreased. A positive acknowledgement from the D-ONU is necessary to be sure this report threshold has been adjusted before the OLT can be updated. If a D-ONU does not respond to this command, the OLT cannot be certain of the report threshold at the D-ONU. Rather than risk correct network behavior for all other ONUs registered on the PON, the D-ONU that fails to acknowledge this command is deregistered.

6.3.3 Set OAM Rate

[802.3] Clause 57 and its annexes specify a maximum rate of 10 frames/second for OAM traffic. DPoE OAM extensions allow this limit to be increased or waived entirely. However, both the DPoE System and D-ONU must agree on the actual OAM frame rate to be used. If the D-ONU and DPoE System use different OAM frame rates, the useful PDU rate would be limited by the lower of the two, as the ONU would either fail to acknowledge OAM commands (when the DPoE System rate was higher than the D-ONU) or be unable to use the increased limit (as the DPoE System would not send commands as often as the D-ONU might be willing to accept).

6.4 OAM Keep-alive Failure

[802.3] requires that the OAM layer return to the initial state of the OAM Discovery state machine on OAM heartbeat failure, but says nothing specifically about the Multi-Point Control Protocol (MPCP) layer in this case. It is conceivable that the OAM layer fails because of some fault in the underlying Ethernet layer controlled by MPCP. If this layer cannot transport frames, it cannot transport OAM frames, and thus resetting only the OAM layer is not likely to recover the D-ONU if the problem lies with MPCP or the Ethernet layer.

DPoE Systems MUST deregister D-ONUs at the MPCP layer if an OAM layer failure is detected. D-ONUs MUST deregister and re-register at the MPCP layer if an OAM layer failure is detected.

¹² Revised per OAMv2.0-N-14.0192-1 on 7/18/14 by JB.

6.5 OAM and Logical Links

The DPoE System MAY use any logical link that terminates at the appropriate D-ONU to send OAM commands. The D-ONU MUST respond to commands on the same logical link on which the command was received.

7 [802.3] OAM PDU

In addition to the [802.3] organization-specific extension PDU opcode (0xFE), which allows definition of entirely new PDUs in addition to the standard [802.3] Clause 57 PDUs, two of the other [802.3] Clause 57 PDUs contain TLVs, which allow for extensions. The Info OAM PDU and the Event Notification OAM PDU are each composed of a series of TLVs. Each type of PDU allows an organization-specific TLV with contents as defined by that organization.

This DPoE specification defines TLVs for both the [802.3] Info PDU and the [802.3] Event Notification PDU, in addition to DPoE OAM extension PDU types (hereafter called DPoE OAM PDU types). As per [802.3], DPoE OAM extension TLVs use TLV type of 0xFE and the DPoE OUI 0x001000.

7.1 Info PDU

All DPoE Info TLVs have as their first type an additional TLV type that allows for multiple different types of DPoE Info TLVs. Format of additional data in the TLV depends on this DPoE TLV type.

Table 10 - DPoE Info TLV Format

Width (Octets)	Field	Value (hex)
1	TLV Type	0xFE (Info TLV extension)
1	Length	Includes Type and Length fields, plus data to follow
3	OUI	0x001000
1	DPoE Info TLV Type	See Table 11

The DPoE Info TLV types are shown in Table 11.

Table 11 - DPoE Info TLV Types

DPoE TLV Type	Value (hex)
DPoE OAM Support	0x00

7.1.1 Info TLV: DPoE OAM Support (0x00)

Presence of this TLV in the Info frames during OAM discovery indicates the DPoE System or D-ONU supports DPoE OAM. Support for the OAM PDUs also implies support for the feature set required for the DPoE System.

The 'DPoE OAM Version' field indicates the version of the eOAM supported by the given device. This field represents a major/minor version number, with the major number in bits [7:4] and the minor number in bits [3:0]. For example, the value of 0b00100000 (0x20) stored in the 'DPoE OAM Version' field represents a major version 2, minor version 0 of the DPoE OAM.

The DPoE System MUST deregister a D-ONU which reports an unsupported version of DPoE OAM.

Table 12 - DPoE OAM Support TLV Format¹³

Width (Octets)	Field	Value (hex)
1	TLV Type	0xFE (Info TLV extension)
1	Length	varies
3	OUI	0x001000
1	DPoE Info TLV Type	0x00
1	DPoE OAM Version	Bits [7:4] represent the major version number Bits [3:0] represent the minor version number The following values are defined: 0x01 – reserved for backward compatibility reasons, same as 0x10 0x02 – pre-DPoE OAM, without Certificate Authority support 0x03 – pre-DPoE OAM, with Certificate Authority support 0x10 – OAM compliant with DPoE-SP-OAMv1.0-I04 and previous versions 0x11 – OAM compliant with DPoE-SP-OAMv1.0-I05 and subsequent versions of DPoE-SP-OAMv1.0 0x20 – OAM compliant with DPoE-SP-OAMv2.0-I01 and subsequent versions 0x21 – OAM compliant with DPoE-SP-OAMv2.0-I06 and subsequent versions 0x22 – OAM compliant with DPoE-SP-OAMv2.0-I08 and subsequent versions 0x23 – OAM compliant with DPoE-SP-OAMv2.0-I10 and subsequent versions Other values are reserved and treated as unsupported.

7.2 Event Notification PDU¹⁴

The DPoE Event Notification TLV is used in an [802.3] Event Notification PDU to provide more detailed alarm information than is possible with only the [802.3] Clause 57 OAM.

All DPoE alarms have a common format. The current condition of the alarm is indicated as "raised" when the condition is detected, and "clear" when the condition is no longer present. The object affected by the condition is included as object type and instance number, which matches the DPoE object context leaf codes and instance parameters in Section 8.7.

Table 13 - DPoE Link Event TLV Format

Width (Octets)	Field	Value (hex)
1	TLV Type	0xFE (Event Notification TLV extension)
1	Length	varies
3	OUI	0x001000
1	Event Code	See Table 14

¹³ Revised per OAMv2.0-N-12.0056-1 on 3/12/13 and per OAMv2.0-N-14.0192-1 on 7/18/14 by JB. Revised per OAM-N-15.0221-2 on 10/30/15 by JB. Revised per OAMv2.0-N-16.0247-3 on 11/01/16 by JB.

¹⁴ Revised text and tables per OAMv2.0-N-12.0059-2 on 3/13/13 by JB.

Width (Octets)	Field	Value (hex)
1	Raised	Boolean; TRUE if the condition currently exists; FALSE if it has been cleared
2	Object Type	Affected object (leaf code for object context, branch D6)
2 or 4	Object Instance	Affected instance of this type of object. Queue object type requires four (4) bytes, other object types require two (2) bytes.

Possible values for the Event Code are shown in Table 14. These alarm codes are grouped into Link Faults, Critical Events, and Dying Gasp alarm types, with code values numbered accordingly.

In addition to this standard header, individual alarm types may contain further alarm-type-specific information in the TLV.

Table 14 - DPoE Event Codes¹⁵

DPoE Event Code	Value (hex)	Description	Relevant Object Context(s)
Link Fault Alarms			
LOS	0x11	Loss of received optical power by the transceiver (ONU EPON port) Link down on Ethernet PHY (ONU UNI port)	D-ONU Network PON Port User Port
Key Exchange Failure	0x12	D-ONU did not observe a switch to a new key after key exchange	Unicast Logical Link
Reserved	0x13..0x1F	Reserved	
Critical Event Alarms			
Port Disabled	0x21	Ethernet port is disabled by management action	Network PON Port User Port
Reserved	0x22..0x3F	Reserved	
Dying Gasp Alarms			
Power Failure	0x41	Loss of power at the D-ONU (Dying Gasp)	D-ONU
Reserved	0x42..0x7F	Reserved	
Other Alarms			
Statistics Alarm	0x81	Statistic has crossed defined alarm thresholds	Network PON Port Unicast Logical Link User Port Queue Multicast Logical Link
D-ONU Busy	0x82	D-ONU is busy and unable to acknowledge or process further OAM until alarm clears	D-ONU
MAC Table Overflow	0x83	D-ONU MAC Table has seen more addresses than it can hold	D-ONU Network PON Port User Port
PON_IF_Switch	84	PON interface on the ONU was switched to backup	D-ONU
Reserved	0x84..0xFF	Reserved	

¹⁵ Revised per OAMv2.0-N-14.0192-1 on 7/18/14 by JB. Revised per OAMv2.0-15.0224-1 on 2/11/16 by JB.

7.2.1 LOS (0x11)

For the TU interface port, a Loss Of Signal (LOS) condition is detected by lack of incoming optical power or loss of Clock and Data Recovery (CDR) lock to the downstream bit clock. On an S interface (or reference point), the LOS condition corresponds to the Link Down condition detected by the S interface (or reference point) PHY.

7.2.2 Key Exchange Failure (0x12)

The Key Exchange Failure alarm indicates that a scheduled key exchange has failed to successfully complete. Encryption continues with the previous key for another key exchange interval. Another key exchange will be attempted at the next key exchange time. See [DPoE-SECv2.0] for details on key exchange procedures and detection of failure conditions.

7.2.3 Port Disable (0x21)

The Port Disabled event indicates that a D-ONU port has been disabled by management action. If the TU interface port is disabled, then OAM cannot be transmitted, and this alarm will be visible only locally on the D-ONU.

7.2.4 Power Failure (0x41)

A Power Failure alarm indicates that the D-ONU has lost power and will imminently depart the DPoE Network. A D-ONU will exercise its best effort to send an Event Notification PDU with this TLV when it detects loss of power. A D-ONU might not be able to actually send the message if the required transmission grants are not allocated by the DPoE System before the D-ONU has exhausted its endurance.

7.2.5 Statistics Alarm (0x81)

The Statistics Alarm indicates a crossing of predefined thresholds on some statistic (indicated in the alarm TLV). Typically, these thresholds would be set for counters for error conditions such as CRC errors. The Statistics Alarm TLV carries the following fields after the standard DPoE alarm TLV fields.

Table 15 - Statistics Alarms Additional Fields

Width (Octets)	Field	Value (hex)
1	Branch	Branch of statistic that crossed threshold
2	Leaf	Leaf of statistic that crossed threshold

7.2.6 D-ONU Busy (0x82)

The D-ONU Busy alarm may be raised by a D-ONU to inform the DPoE System that it has become busy for an extended period and may not respond to further OAM requests in the usual timely fashion.

The DPoE System MUST ignore any OAM or eOAM timeout alarms as long as the "ONU Busy" alarm is active (raised), but not longer than 300 seconds from the last reception of the "ONU Busy" alarm. The DPoE System MUST NOT ignore any OAM or eOAM timeout alarms longer than 300 seconds from the last reception of the "ONU Busy" alarm.

7.2.7 MAC Table Overflow (0x83)

The MAC Table Overflow alarm is raised by a D-ONU to inform the DPoE System that an ingress MAC address has not been learned because the total number of MAC addresses has been exceeded. For example, if the D-ONU has been provisioned to allow four MAC addresses on a particular UNI port, then the first four addresses seen would be learned; the fifth address would cause this alarm to be raised.

8 DPOE OAM PDUS

All DPoE OAM PDU messages follow the [802.3] Clause 57-defined method of extending the OAM protocol. That is, the messages are contained in [802.3] Clause 57-defined Organization-specific OAM frames, followed by the DPoE OUI 0x001000. See Section 5.2 for more details on [802.3] Clause 57 OAM PDU formats.

Table 16 - DPoE Extended OAM PDU Format

Width (Octets)	Field	Value (hex)
6	Ethernet DA	0x0180C2-000002 ([802.3] OAM multicast address)
6	Ethernet SA	As per sending MAC
2	EtherType	0x8809 (Ethernet Slow Protocol)
1	Subtype	0x03 ([802.3] OAM)
2	Flags	As per [802.3]
1	Opcode	FE
3	OUI	0x001000
1	DPoE Opcode	See Table 17

Each DPoE OAM message type is identified by a one-byte opcode immediately following the DPoE OUI. Data per individual extended DPoE OAM PDU type then follows as defined for that particular DPoE Opcode (see Table 17).

Table 17 - DPoE Opcodes¹⁶

DPoE Opcode	Value (hex)
Reserved	0x00
Get Request	0x01
Get Response	0x02
Set Request	0x03
Set Response	0x04
Reserved, ignored on reception	0x05
Reserved, ignored on reception	0x06
Reserved, ignored on reception	0x07
Key Exchange	0x08
File Transfer	0x09
Reserved, ignored on reception	0x0A
Reserved, ignored on reception	0x0B
Reserved, ignored on reception	0x0C
eOAM_Early_WakeUpOLT	0xFC
eOAM_Early_WakeUpONU	0xFD
eOAM_Sleep_Allowed	0xFE

Most management functions in DPoE Systems are carried out by reading and writing individual attributes of objects in the D-ONU with the Get and Set PDUs. Setting an S interface port speed, for example, would be performed by setting the port speed attribute of the proper port object. These PDUs are essentially lists of TLVs, where each TLV represents an attribute. Since more than one instance of an object could exist in the D-ONU, the packet also contains TLVs that identify the object to which later attributes in the PDU will apply. That is, some TLVs set the current

¹⁶ Revised per OAMv2.0-N-14.0143-1 on 5/30/14 by JB. Revised per OAMv2.0-N-14.0199-1 on 11/20/14 by JB. Revised per OAM-N-15.0221-2 on 10/30/15 by JB.

object context to which later attributes apply. Since the PDU is a list format, it is possible to conduct a number of operations on one object or several objects with just one PDU. See Section 8.2 for a description of Variable Descriptors and Variable Containers as found in the Get and Set PDUs.

Other OAM PDU types exist for specialized purposes that do not fit the object as well, such as file transfer.

8.1 Definitions of DPoE OAM PDUs¹⁷

8.1.1 Get Request

The Get Request permits reading of both [802.3] Clause 30 and DPoE extended attributes in a single PDU. The data field of the PDU contains a null-terminated series of Variable Descriptors, as defined in [802.3] Clause 57 Variable Request messages.

8.1.2 Get Response

This Get Response OAM PDU is a response to a Get Request. The data field of the PDU contains a null-terminated series of Variable Containers, as defined in [802.3] Clause 57 Variable Request messages, where the values in the Containers are the value of the queried attributes, or possibly an error response code.

8.1.3 Set Request

[802.3] Clause 57 does not include means to set variables with OAM messages. It can only retrieve them with a Variable Request message. The DPoE OAM supports the setting of variables.

The format of the Set OAM PDU is similar to the Variable Response PDU. A null-terminated list of Variable Containers specifies which variables to set. The values in the Variable Containers provide new values to be set for the attribute.

The Set Request OAM PDU may contain Actions (branch 0x09 or 0xD9) as well as attributes. Actions instruct the receiving device to execute a procedure, such as clearing a table or resetting. The management actions specified in [802.3] Clause 30 are not supported in the [802.3] Clause 57 PDUs. The DPoE extensions allow these standard management actions and extended actions to be requested. Actions that have parameters (as defined for each action) have those parameters as the body of the Variable Container for the action. Actions that do not have parameters are represented as a Variable Container of zero length (length code 0x80).

Actions are distinct from setting variables, though they can have similar affects. An SNMP MIB contains "trigger attributes" that create the same effect as an action. For example, in SNMP, setting a Boolean "Reset" attribute to TRUE for a device instructs the management system to reset the device. Similarly, some attributes in [802.3] Clause 30 can be used to change system settings. For example, setting the AdminState of a PHY can turn the device on or off.

8.1.4 Set Response

A Set Response OAM PDU contains a null-terminated series of Variable Containers. The response codes correspond to individual Set requests or Actions in the Set Request PDU. The container typically consists of the Branch/Leaf identifier and the Width field. The Width field contains an error code.

8.1.5 Key Exchange

The Key Exchange PDU is used by encryption firmware to exchange keys and synchronize key switchover. See [DPoE-SECv2.0] for details on the key exchange protocols used by the DPoE Network.

¹⁷ Revised per OAMv2.0-N-14.0199-1 on 11/20/14 by JB. Revised per OAM-N-15.0221-2 on 10/30/15 by JB.

8.1.6 File Transfer

The File Transfer PDU is used by the file transfer protocol used to upgrade D-ONU firmware. See Section 12 for details on file transfer PDUs and protocol specifications.

8.1.7 eOAM_Early_WakeUpOLT

See [1904.1A], subclause 13.4.2.12.

8.1.8 eOAM_Early_WakeUpONU

See [1904.1A], subclause 13.4.2.13.

8.1.9 eOAM_Sleep_Allowed

See [1904.1A], subclause 13.4.2.14.

8.2 Attribute List

The DPoE OAM Get Request and Set Request PDUs and corresponding Get Response and Set Response OAM PDUs consist of a list of Variable Descriptors or Variable Containers, as defined in [802.3] Clause 57 for the contents of the standard Variable Request and Variable Response PDUs.

A Variable Descriptor is a 3-byte value composed of a one-byte "branch" code and a two-byte "leaf" code, which uniquely identifies a particular attribute.

Table 18 - Variable Descriptor

Width (Octets)	Field	Value (hex)
1	Branch Code	0x0: (end of list) 0x01 ... 0xFF
2	Leaf Code	0x00 00..0xFF FF

Variable Containers consist of a branch/leaf pair, followed by a one-byte field that represents the length of data in the container, followed by the actual data that is the value for that attribute. Thus, a Variable Container has a typical Type-Length-Value (TLV) structure, with a compound Type field. A Variable Descriptor is just the Type portion of this TLV.

Table 19 - Variable Container

Width (Octets)	Field	Value (hex)
1	Branch Code	
2	Leaf Code	
1	Length	0x00: length of data to follow is 128 bytes 0x01..7F: length of data to follow in bytes 0x80..FF: Response/error code (implies zero length of data follows)
varies	Value	Present only when length is greater than zero; format as defined for the branch/leaf code

For brevity, the acronym "TLV" is used to refer to either Variable Descriptors or Variable Containers, even though Variable Descriptors do not actually have a length or value field.

The series of TLVs in a PDU is terminated by a Variable Container or Variable Descriptor with branch, leaf, and length values of 0.

As per [802.3] Clause 57 OAM Variable Containers, Variable Container length values from 1-127 represent the length of data in the container. Zero represents a length of 128 bytes. Values 128 (0x80) and higher represent a response code to the request, indicating the result of the attempted action. All response codes imply a length of zero for the data length.

Table 20 - DPoE Variable Response Codes

DPoE Variable Response Codes	Meaning	Value (hex)
No Error	The operation was successfully completed. This value is also used to represent zero length in Variable Containers with no data, such as in the Set PDU for actions with no parameters.	0x80
Too Long	Length of result exceeded OAM PDU data field available	0x81
Bad Parameters	Parameters for the requested action fail error checking	0x86
No Resources	The device does not currently have the resources (table entries, memory, etc.) to perform the requested action	0x87
System Busy	The device is not currently in the proper state to perform the requested action	0x88
Undetermined Error	Unknown or unlisted Attribute error	0xA0
Unsupported	The Attribute requested is not supported on this device	0xA1
May Be Corrupted	The value of an Attribute counter may be invalid due to reset	0xA2
Hardware Failure	An Attribute hardware error prevented the operation from completing	0xA3
Overflow	Requested Attribute experienced overflow error	0xA4

8.3 Data Formats

Variable Containers contain data of several common types. This section describes the format of these data types.

8.3.1 Integers

Integers are represented in two's-complement form, most significant byte first. Note that Containers are variable length; as a result, attributes that are integers do not have a fixed width. The transmitter may suppress leading zero bytes of integers. The receiving D-ONU or DPoE System must handle an integer in a Variable Container of any legal width (1..128 bytes). If a Variable Container is smaller than the receiving device representation, the value is extended as necessary. If the Variable Container is larger than the receiving device representation, the result is implementation-defined.

8.3.2 Enumerated Values

Enumerated values take one of a number of bit patterns with predefined meanings. Enumerated values are always represented in a Container with a width equal to that necessary for the largest possible such value in that particular enumerated value, with leading zeros as necessary when the actual value is shorter than the maximum possible.

8.3.3 Sequences

A "sequence" is a series of values, usually enumerated values. Every element in a sequence must have the same width. The number of elements in the sequence can thus be determined from the width of the Variable Container.

8.3.4 Structured Data Types

Many attributes consist of structured data with a number of sub-fields. The format of such structured data depends on the attribute, and is shown in a table in the definition of individual attributes below.

8.4 Storage Classes¹⁸

OAM attribute description provides a “storage class” for each attribute, which defines the behavior of the attribute in memory.

The lack of any notation at the OAM attribute indicates that the attribute is Read-Write (RW). The vCM may write into this attribute with a Set PDU and read from this attribute with a Get PDU.

“R” denotes a Read-Only attribute. The vCM may read from this attribute with a Get PDU, but cannot Set the value stored in this attribute.

“NVS” denotes an attribute kept in Non-Volatile Storage. NVS attributes, unlike normal attributes, retain their values when an ONU resets, including power-on resets. An NVS attribute retains its value after a reset as last set with a Set PDU. Non-NVS attributes return to a default value as listed in the spec after a reset.

8.5 Large Values

The maximum length of data that can fit into a single Variable Container is 128 bytes. Some attribute values may be larger. Values larger than 128 bytes long are represented by a contiguous series of Variable Containers with a repeated branch/leaf code for the attribute in question. This series of TLVs is terminated by a TLV with the same branch/leaf code, and a length of zero, to indicate the end of the large value.

The attribute value is segmented into the several TLVs as described for particular attributes. For ease of segmentation and reassembly, the value for tables of items is not necessarily broken at 128 byte boundaries, but rather the closest boundary that contains an integral number of table items. For example, a MAC address table consisting of a large number of entries, each 6 bytes long, can hold at most 21 whole MAC addresses in whole TLV (21 x 6 = 126 bytes). Rather than break the 22nd MAC address across two TLVs, the first TLV would contain 126 bytes and the next the remainder of the value.

Example

A Get PDU contains a single Var Container to request the MAC address table from a D-ONU:D7 01 03.

Assume further that the polled D-ONU currently has 23 learned MAC addresses, and returns the response using three Variable Containers in the PDU, 21 addresses in the first TLV and 2 in the second, followed by the large value terminator:

```
0xD7 01 03 7E 11 12 13 14 15 16. .
```

```
0xD7 01 03 0C 21 22 23 24 25 26 31 32 33 34 35 36
```

```
0xD7 01 03 80
```

8.6 Multiple Part OAM Responses¹⁹

Certain responses from the D-ONU to a single PDU from the DPoE System may not fit within a single OAM frame. (Variable Containers are larger than Variable Descriptors, and some values can be much larger than a single frame. Such attributes include D-ONU rule tables and learning tables.) In this case, the D-ONU must split its response across multiple OAM PDUs. The D-ONU MUST then inform the DPoE System that the complete response was not sent in one frame. In addition, the DPoE System MUST be able to detect missing OAM PDUs from a series needed to form the complete response.

To indicate that further response messages are forthcoming, the D-ONU adds a particular TLV known as a Sequence Number TLV to its response PDU.

A D-ONU SHOULD NOT insert a Sequence Number TLV into a single part response frames.

¹⁸ Revised per OAMv2.0-N-12.0056-1on 3/12/13 by JB.

¹⁹ Revised per OAMv2.0-N-12.0056-1on 3/12/13 by JB.

The Sequence Number TLV has the following format:

Table 21 - Sequence Number TLV

Field	Description	Value (hex)
Branch	Branch Attribute	0xD7
Leaf	Multi-Part Response Sequence Number	0x00 01
Length	One 16-bit unsigned integer	0x02
Sequence #	Bit 15, when set, indicates that this is the last message of its sequence. Bits 0-14 are a 15 bit sequence number.	(variable)

To send a multiple part response requiring N PDUs, the D-ONU does the following:

For the first PDU in the sequence:

Set Sequence# = 0

For the last PDU of the sequence:

Set bit 15 of Sequence#

For all PDUs in the sequence:

Add a sequence TLV with the value {0xD7, 0x0001, Sequence#}

Send the OAM PDU

Increment **Sequence#**

Figure 6 presents a sample message exchange:

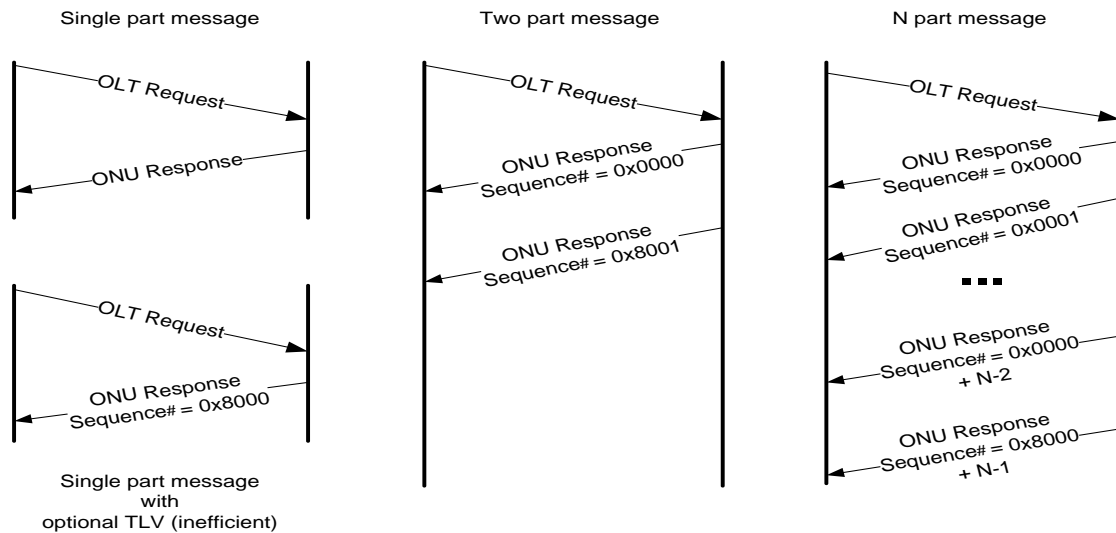

Figure 6 - Sample Message Exchange

8.7 Object Context (Branch 0xD6)²⁰

DPoE OAM extensions can manage objects other than the immediate EPON MAC instance. Also, since a D-ONU typically supports multiple ports, any attribute such as "Bytes Received" may have many instances, one for each port on the D-ONU. Therefore, the particular instance of an object must be identified to provide context for the attributes or actions.

An object context tuple in an OAM PDU sets the object to which all subsequent Variable Descriptors or Containers apply. This remains unchanged until the next object context in the PDU is processed, or the message ends. If no object context is supplied, the default context is the logical link (LLID) on which the OAM PDU was received.

A DPoE ONU is assumed to have 1 or more Ethernet interfaces in addition to the TU interface. TU Interfaces and Ethernet interfaces are identified by an 8-bit ID number that ranges from 0..N-1, using two separate numbering spaces for TU interfaces and Ethernet interfaces. The relationship of interface numbers to actual physical interfaces is defined by the DPoE ONU, but the relationship is always the same for any given DPoE ONU.

It is not necessary for the DPoE System to know the MAC addresses of the user ports to manage them via DPoE OAM.

Table 22 - Object Context

Leaf (HEX)	Attribute	Description
0x00 00	D-ONU	D-ONU
0x00 01	Network PON Port	A PON port on the network side of the device
0x00 02	Unicast Logical Link	Unicast logical link
0x00 03	User Port	User-side Ethernet port
0x00 04	Queue	A single queue
0x00 05	MEP	A Service OAM frame generator Maintenance Endpoint (MEP)
0x00 06	Multicast Logical Link	Multicast (unidirectional) logical link
0x00 07	Reserved	Defined in [DPoG-OAM] Specification

8.7.1 D-ONU Object (0xD6/0x0000)

The D-ONU object identifies the D-ONU as a whole. In most cases, this object is obvious because the D-ONU is the one processing the DPoE OAM message. In some cases, a DPoE OAM PDU may want to make the current context less specific for a particular attribute. The D-ONU Object is also necessary for some other uses, such as in an alarm TLV.

The instance number for the D-ONU object is always 0.

Table 23 - D-ONU Object

Width (Octets)	Field	Value (hex)
1	D-ONU instance	0

8.7.2 Network Port Object (0xD6/0x0001)

The Network Port object identifies one of the network-side PON ports (TU interface) on the device. Network Ports are numbered sequentially starting from 0. This object cannot identify S₁ interfaces.

²⁰ Revised per OAMv2.0-N-12.0059-2 on 3/13/13 by JB. Revised per OAMv2.0-N-14.0192-1 on 7/18/14 by JB. Revised per OAMv2.0-N-14.0200-1 on 11/20/14 by JB.

Table 24 - Network Port Object

Width (Octets)	Field	Value (hex)
1	PON Number	0..N-1

8.7.3 Unicast Logical Link (0xD6/0x0002)

The Unicast Logical Link object identifies one of the unicast logical links registered by the D-ONU. A Unicast Logical Link instance is identified by an index that matches an LLID index in the LLID and Queue Configuration (0xD7/0x010D) attribute (see Section 9.2.13)..

Table 25 - Unicast Logical Link Object

Width (Octets)	Field	Value (hex)
1	LLID Index	0..L-1

8.7.4 User Port Object (0xD6/0x0003)

The User Port object identifies one of the S interfaces or references points on the device (if any). S₁ interfaces are numbered sequentially starting from 0.

Table 26 - User Port Object

Width (Octets)	Field	Value (hex)
1	UNI Number	0..N-1

8.7.5 Queue Object (0xD6/0x0004)

Queues are numbered relative to their egress port. Queue numbers start with the value 0, which is the highest priority queue, up to the value N-1, where N is the number of queues that terminate on a port. The value 0xFFFF is a special value that means "all queues for this port". This context is primarily useful for bulk statistics queries from all queues at once, as it saves setting a queue context for each queue.

Table 27 - Queue Object

Width (Octets)	Field	Value (hex)
2	Object Type	See Section 8.7. (Only User Port and Unicast Logical Link objects have queues.)
1	Object Instance	0..N-1
1	Queue Number	0..Q-1

8.7.6 Multicast Logical Link Object (0xD6/0x0006)

The Multicast Logical Link object identifies one of the multicast logical links registered in the D-ONU. A Multicast Logical Link instance is identified by 16-bit LLID value, rather than the D-ONU LLID index, as is the case for unicast logical links. This allows using the same object context values for querying multicast statistics for any D-ONU in a given multicast group.

Table 28 - Multicast Logical Link Object

Width (Octets)	Field	Value (hex)
2	Multicast LLID Value	Any

8.8 Broadcast eOAM

Broadcast eOAM, or the “broadcast eOAM channel,” uses the eOAM message structure as defined in [802.3], but instead of transmitting the frame on a unicast LLID assigned to a D-ONU, the eOAM frame is transmitted using the broadcast LLID. In this manner the eOAM frame is received by all D-ONUs on the PON. The D-ONU is not expected to reply to eOAM messages received on the broadcast LLID.

8.9 Reserved Branch (0xC7)

The branch value 0xC7 is reserved for use in DOCSIS Provisioning of GPON specifications.

9 OAM ATTRIBUTES BY FUNCTION²¹

This section further details each DPoE OAM attribute. Each attribute name is listed by its Branch/Leaf designation. For example, "Get Firmware Version (D7/80)," where the first number (D7) is the branch and the second number (80) is the leaf. These branch/leaf values are in hexadecimal. Where applicable, units for measurement and allowed ranges are specified.

Some attributes, particularly capabilities, are read-only. These attributes are denoted by an "R" after their value. Some writeable attributes are non-volatile, which is to say they persist after the D-ONU has been reset. These attributes are marked with an "NV".

9.1 D-ONU Management²²

9.1.1 Device ID (0xD7/0x0002) R

Objects: D-ONU

The ONU Device ID is a non-volatile number that uniquely identifies a physical D-ONU. By definition, the D-ONU Device ID is the lowest (numerically smallest) MAC address among all MAC addresses associated with the TU interface port of a D-ONU. All logical links on a D-ONU report the same D-ONU Device ID, despite having different link MAC addresses (per [802.3]).

9.1.2 Firmware Info (0xD7/0x0003) R²³

Objects: D-ONU

This attribute represents the D-ONU firmware version. The version number uniquely identifies a particular version of the D-ONU firmware. Format is defined by the D-ONU vendor. DPoE Systems can compare this value for equality with a provisioned value for the currently correct firmware version. "Newer than" or "compatible with" comparisons depend on version number format and should not be performed with a simple comparison. The Boot Version can be used to populate the BOOTR field in the sysDescr MIB object. Version values 0x0000 and 0xFFFF are reserved, and indicate loads that are not installed or are not available.

Table 29 - Firmware Info

Size	Name	Description
2	Boot Version	Version of bootstrap loader (if any)
4	Boot CRC-32	CRC-32 of boot loader serves as additional unique identifier and verification
2	Firmware Version	Version of main firmware running on the D-ONU
4	Firmware CRC-32	CRC-32 of firmware serves as unique ID and verification

²¹ Revised per OAMv2.0-N-14.0192-1 on 7/18/14 and OAMv2.0-N-14.0200-1 on 11/20/14 by JB.

²² Revised per OAMv2.0-N-12.0056-1 on 3/12/13 by JB.

²³ Revised per OAMv2.0-N-13.0066-2 on 3/13/13 by JB. Revised per OAMv2.0-N-16.0247-3 on 11/1/2016 by JB.

9.1.3 Chipset Info (0xD7/0x0004) R

Objects: D-ONU

This attribute represents the type of chip used on the D-ONU.

Table 30 - Chipset Info

Size	Name	Description
2	JEDEC ID	16-bit chip manufacturer ID code as assigned by JEDEC
4	Chip Model	Identifies the particular kind of EPN chip. Format defined by chipset vendor
4	Chip Version	Identifies the version or stepping of the chip model. Format defined by chipset vendor

9.1.4 Date of Manufacture (0xD7/0x0005) R

Objects: D-ONU

The date the D-ONU was manufactured, encoded in Binary Coded Decimal (BCD) digits as YYYYMMDD. For example, June 24, 2010, would be represented as 20 10 06 24.

Table 31 - Date of Manufacture

Size	Name	Description
2	Year	BCD
1	Month	BCD
1	Day	BCD

9.1.5 Manufacturer Info (0xD7/0x0006) R²⁴

Objects: D-ONU

This attribute holds manufacturer-specific information that identifies this individual D-ONU.

Table 32 - Manufacturer Info

Size	Name	Units
32	Serial Number	String
32	Manufacturer Name	String

9.1.6 Max Logical Links (0xD7/0x0007) R

Objects: D-ONU

The maximum number of logical links the D-ONU supports on the EPON.

Table 33 - Max Logical Links

Size	Name	Description
2	Bidirectional	Maximum number of links which can both transmit and receive
2	Downstream-only	In addition to the bidirectional links, the maximum number of LLIDs which can receive data, but not transmit (unidirectional, downstream only)

²⁴ Revised per OAMv2.0-N-16.0247-3 on 11/1/2016 by JB.

9.1.7 Number of Network Ports (0xD7/0x0008) R

Objects: D-ONU

This attribute provides the total number of TU interface ports on the D-ONU.

9.1.8 Number of S₁ interfaces (0xD7/0x0009) R

Objects: D-ONU

This attribute provides the number of S₁ interfaces on the D-ONU.

9.1.9 D-ONU Packet Buffer (0xD7/0x000A) R

Objects: D-ONU

This message provides a means for the D-ONU to convey information about packet buffer capabilities to the DPoE System.

Table 34 - D-ONU Packet Buffer

Size	Name	Description
1	Upstream Queues	Total number of queues available to be assigned to logical links in the upstream direction
1	Up Queues Max Per Link	Maximum number of queues which can be assigned to a single logical link in the upstream direction
1	Up Queue Increment	The smallest allocatable increment of packet buffer memory in the upstream direction, in kilobytes
1	Downstream Queues	Total number of queues available to be assigned to logical links in the downstream direction
1	Dn Queues Max Per Port	Maximum number of queues which can be assigned to a single UNI port in the downstream direction
1	Dn Queue Increment	The smallest allocatable increment of packet buffer memory in the downstream direction, in kilobytes
2	Total Packet Buffer	Total packet buffer memory on the D-ONU (KB)
2	Up Packet Buffer	Maximum amount of packet buffer memory which can be allocated to upstream queues
2	Dn Packet Buffer	Maximum amount of packet buffer memory which can be allocated to downstream queues

9.1.10 Report Thresholds (0xD7/0x000B)

Objects: Unicast Logical Link

This attribute represents the threshold levels used to generate REPORT MPCPDUs. The format corresponds closely to the format of the REPORT MPCPDU, except that the bitmaps for report values present are omitted. The message specifies the number of queue sets and the number of report values in each queue set to be used on the link. A DPoE System MUST insure the number of report values in each queue set is the same. For each queue set and report value, a threshold is specified.

A DPoE System MUST ensure the report thresholds for successive queue sets are increasing. A DPoE System MUST ensure the report thresholds for successive queue sets are cumulative. For example, Report Threshold 0 for Queue Set 1 must be equal to or greater than Report Threshold 0 in Queue Set 0. A higher numbered queue set includes all the data reported in earlier queue sets, plus possibly some additional data.

Table 35 - Report Thresholds

Size	Description	Units	Default	Min	Max
1	Number of Queue Sets		4	1	4
1	Report Values Per Queue Set		1	1	8
2	Report Threshold 0 for Queue Set 0	EPON TQ	2048	0	0xFFFF

Size	Description	Units	Default	Min	Max
	...				
2	Report Threshold n-1 for Queue Set 0	EPON TQ	-	0	0xFFFF
	...				
2	Report Threshold 0 for Queue Set n-1	EPON TQ	-	0	0xFFFF
	...				
2	Report Threshold n-1 for Queue Set n-1	EPON TQ	-	0	0xFFFF

9.1.11 Logical Link Forwarding State (0xD7/0x000C) R

Objects: Unicast Logical Link

This attribute represents the current traffic state for a logical link. User data traffic may be enabled (normal operation) or disabled (discarded by the D-ONU). Only OAM and MPCP remain enabled regardless of the logical link forwarding state. See Enable/Disable User Traffic (Section 9.7.10 and Section 9.7.11) for actions that change this state.

Table 36 - Link State

Size	Description	Units	Default	Min	Max
1	Link State (0=Disable, 1=Enable)	Boolean	0	0	1

9.1.12 OAM Frame Rate (0xD7/0x000D)

Objects: Unicast Logical Link

This attribute represents the maximum rate at which OAM PDUs are transmitted on a link.

Setting the Maximum OAM Frame Rate to 0 disables rate control.

The Minimum OAM Frame Rate is the heartbeat rate. This is the rate at which OAM PDUs are sent between the D-ONU and DPoE System, using an Info PDU as a "heartbeat" if there is no other OAM activity, as per [802.3]. The heartbeat rate is specified as one heartbeat PDU per specified time interval. The time interval is specified as the value provisioned in the message x 100ms. Therefore, setting the Minimum OAM Frame Rate to 10 specifies a rate of 1 PDU per 10 x 100ms. This equals 1 PDU per 1 second.

The D-ONU implementation maintains one instance of the OAM rate. This rate applies to all links on the D-ONU.

Table 37 - OAM Frame Rate

Size	Description	Units	Default	Min	Max
1	Maximum OAM rate	PDUs/100ms	1	0 (Unlimited rate)	25
1	Minimum OAM rate	Number of 100ms	10	0 (no OAM) heartbeat)	10

9.1.13 ONU Manufacturer Organization Name (0xD7/0x000E) R²⁵

Objects: D-ONU

This attribute represents the organization which manufactured the D-ONU. The attribute is an ASCII string, with no null terminator. It is used to validate the manufacturer CVC during secure software download. The value must

²⁵ Revised per OAMv2.0-15.0229-1 on 2/11/16 by JB.

exactly match the subject organizationName value in the firmware manufacturer CVC. See [DPoE-SECv2.0] for details.

Table 38 - ONU Manufacturer Organization Name

Size	Description	Units	Default	Min	Max
varies	Organization name	string	-	-	-

9.1.14 Firmware Mfg Time Varying Controls (0xD7/0x000F) NVS²⁶

Objects: D-ONU

This attribute represents the firmware CVC and CVS validity times as programmed into the D-ONU. The TVC affects the validity of firmware updates. See [DPoE-SECv2.0] for details.

Time values are ASCII strings representing the time in UTC in the format YYMMDDhhmmssZ. Per [DPoE-SECv2.0], dates range from the year 1950 to 2050; the upper two digits of the year are implied.

Table 39 - Firmware Mfg Time Varying Controls

Size	Description	Units	Default	Min	Max
13	Code Access Start	Seconds	-	500101000000Z	491231235959Z
13	CVC Access Start	Seconds	-	500101000000Z	491231235959Z

9.1.15 D-ONU Port Type (0xD7/0x0010)

Objects: D-ONU

This message provides a means for the D-ONU to convey information about the type of individual ports and devices connected to them (if present), including embedded (eSAFE) and other known CPE type devices. There are in total N ports available on the D-ONU, including physically exposed ports (MI/MU/CMCI) as well as embedded ports (LCI) connecting to eSAFE devices.

This attribute contains N entries, one for each port on the D-ONU, where each entry corresponds to the D-ONU port type and indicates the device type that is connected to this port (if any). Each port on the D-ONU can be associated with one and only one device type.

Table 40 - D-ONU Port Type

Size	Name	Description
1	Port 0 type	This field describes type of device connected to port 0 on D-ONU. This field carries one of the values defined in Table X2.
1	Port 1 type	This field describes type of device connected to port 1 on D-ONU. This field carries one of the values defined in Table X2.
1	Port N-1 type	This field describes type of device connected to port N-1 on D-ONU. This field carries one of the values defined in Table X2.

²⁶ Revised per OAMv2.0-N-12.0048-1 by JB on 3/12/13.

Individual port types are enumerated in Table 41.

Table 41 - Port type enumeration

Port type value	Enumeration (designation)	Description
0x00	unspecified	Given D-ONU port is not connected to a known external or internal device
0x01	eMTA	Given D-ONU port is connected to a PacketCable/eMTA
0x02	eSTB-IP	Given D-ONU port is connected to an eSTB-IP
0x03	eSTB-DSG	Given D-ONU port is connected to an eSTB-DSG
0x04	eTEA	Given D-ONU port is connected to an eTEA
0x05	eSG	Given D-ONU port is connected to an eSG
0x06	eRouter	Given D-ONU port is connected to an eRouter
0x07	eDVA	Given D-ONU port is connected to an eDVA
0x08	SEB eSTB-IP	Given D-ONU port is connected to a SEB eSTB-IP
0x09 – 0xFF	Reserved and ignored on reception	

9.1.16 Vendor Name (D7/00 11) R²⁷

This attribute represents the ONU vendor name. The attribute is an ASCII string, with no null terminator. It can be used to populate the VENDOR field in the sysDescr MIB variable (see [DPoE-OSSIV2.0]), and may or may not be the same as the ONU Manufacturer Organization Name. Format of the vendor name is vendor specific. The D-ONU SHOULD limit the vendor name length to less than 32 bytes.

Table 42 - ONU Manufacturer Organization Name

Size	Description	Units	Default	Min	Max
varies	Vendor name	string	-	-	-

9.1.17 Model Number (D7/00 12) R²⁸

This attribute represents the ONU model number. The attribute is an ASCII string, with no null terminator. It can be used to populate the MODEL field in the sysDescr MIB variable (see [DPoE-OSSIV2.0]). Format of the model number is vendor specific. The D-ONU SHOULD limit the model number length to less than 32 bytes.

Table 43 - ONU Model Number

Size	Description	Units	Default	Min	Max
varies	Model number	string	-	-	-

9.1.18 Hardware Version (D7/00 13) R

This attribute represents the ONU hardware version. The attribute is an ASCII string, with no null terminator. It can be used to populate the HW_REV field in the sysDescr MIB variable (see [DPoE-OSSIV2.0]). Format of the hardware version information is vendor specific. The D-ONU SHOULD limit the hardware version length to less than 32 bytes.

²⁷ Sections 9.1.17 - 9.1.19 added per OAMv2.0-N-12.0048-1 by JB on 3/12/13.

²⁸ Tables 41 and 42 updated with corrected table captions and descriptions per OAMv2.0-N-13.0066-2 on 3/13/13 by JB.

Table 44 - ONU Hardware Version

Size	Description	Units	Default	Min	Max
varies	Hardware version	string	-	-	-

9.1.19 EPON Mode (D7/00 14) R ²⁹

This attribute represents the EPON mode(s) supported by this ONU.

DPoE Systems that support 2G-EPON MUST support this attribute. DPoE ONUs that support 2G-EPON MUST support this attribute. DPoE Systems that support 1G-EPON and 10G-EPON SHOULD support this attribute. DPoE ONUs that support 1G-EPON and 10G-EPON SHOULD support this attribute.

Table 45 - ONU EPON Mode

Size	Description	Units	Default	Min	Max
2	EPON Mode	Bitmap	-	-	-

Table 46 - ONU EPON Mode Capabilities Bit Value

EPON Mode	Interpretation of Bit Field
1.25G DS	Bit 1: When set to 1, the ONU supports 1.25 Gb/s downstream line rate When set to 0, the ONU does not support 1.25 Gb/s downstream line rate
2.5G DS	Bit 2: When set to 1, the ONU supports 2.5 Gb/s downstream line rate When set to 0, the ONU does not support 2.5 Gb/s downstream line rate
10G DS	Bit 3: When set to 1, the ONU supports 10.3125 Gb/s downstream line rate When set to 0, the ONU does not support 10.3125 Gb/s downstream line rate
Reserved	Bits 4-7: Reserved for future use
1.25G US	Bit 8: When set to 1, the ONU supports 1.25 Gb/s upstream line rate When set to 0, the ONU does not support 1.25 Gb/s upstream line rate
Reserved	Bit 9: Reserved for future use
10G US	Bit 10: When set to 1, the ONU supports 10.3125 Gb/s upstream line rate When set to 0, the ONU does not support 10.3125 Gb/s upstream line rate
Reserved	Bits 11 – 15: Reserved for future use

9.1.20 Software Bundle (0xD7/0x0015) R ³⁰

Objects: D-ONU

This attribute represents the ONU Software Version. The Software Bundle is used to populate the SW_REV field in the sysDescr MIB object (see [DPoE-OSSIV2.0]). There is not a prescribed versioning format and is not intended for direct comparison to previous software versions. This attribute is a null-terminated ASCII string.

²⁹ Revised per OAMv2.0-N-14.0188-1 on 7/18/14 by JB.

³⁰ Revised per OAMv2.0-N-16.0247-3 on 11/1/2016 by JB.

Table 47 - ONU Hardware Version

Size	Description	Units	Default	Min	Max
varies	Software Bundle	string	-	-	64

9.1.21 Reset D-ONU (0xD9/0x0001)

Objects: D-ONU

This attribute resets the D-ONU, as if from power on.

9.2 Bridging

9.2.1 Dynamic Learning Table Size (0xD7/0x0101) R

Objects: D-ONU

This attribute is a capability attribute that represents the maximum size of the D-ONU MAC address learning table for the D-ONU as a whole. The total number of MAC addresses learned by the D-ONU cannot exceed this number.

Table 48 - Dynamic Learning Table Size

Size	Description	Units	Default	Min	Max
4	Dynamic MAC learning table size	Entries	n/a	1	0xFFFF FFFF

9.2.2 Dynamic Address Age Limit (0xD7/0x0102)

Objects: D-ONU

This attribute represents Dynamic MAC learning table age limit.

Table 49 - Dynamic Address Age Limit

Size	Description	Units	Default	Min	Max
2	Dynamic MAC learning table age limit	10 ms	2000	0	0xFFFF

9.2.3 Dynamic MAC Table (0xD7/0x0103) R

Objects: User Port

This attribute represents the dynamically learned MAC address rules of one Ethernet port. MAC address are repeated within a single attribute until that attribute is full (21 addresses = 126 bytes). If necessary, such attributes are repeated as an attribute list until the entire table has been reported.

Table 50 - Dynamic MAC Table

Size	Description	Units	Default	Min	Max
6	MAC address 0	-	--	-	-
...	MAC address 1	-	-	-	-

9.2.4 Static MAC Table (0xD7/0x0104) R

Objects: User Port

This attribute represents the statically provisioned MAC address table. The data structure is the same as the Get Dynamic MAC Table attribute above.

9.2.5 S₁ Interface Port Auto-negotiation (0xD7/0x0105)³¹

Objects: Network Port, User Port

This attribute represents the auto-negotiation advertisement values used by a port. The set command specifies the values to advertise, while the get command returns the current values along with the values the port can physically support.

Table 51 - S₁ Interface Port Auto-Negotiation

Size	Description	Units	Default	Min	Max
2	Bit array of maximum capabilities (see Table 52). In Set request message, this field is set to 0x00-00 and ignored on reception.	Bitmap	Depends on port	-	-
2	Bit array of current capabilities (see Table 52). A capability is advertised as supported when its bit = 1.	Bitmap	Depends on port	-	-

Table 52 - Port Capabilities

Auto-Negotiation Capability	
Half Duplex	Bit 0 (LSB)
Full Duplex	Bit 1
10 Mbps	Bit 2
100 Mbps	Bit 3
1000 Mbps	Bit 4
10 Gbps	Bit 5
Flow Control	Bit 6
Auto MDI/MDI-X	Bit 7
Unused (set to 0)	Bit 8-15

9.2.6 Source Address Admission Control (0xD7/0x0106)

Objects: User Port

This attribute controls the operation of the MAC Source Address-based admission control function operating on the DPoE ONU port in context in the upstream direction

Table 53 - Source Address Admission Control

Size	Description	Units	Default	Min	Max
1	Indicates whether the Source Address Admission Control for the given DPoE ONU port is enabled or not. 0 = disabled 1 = enabled	enum	0	0	1

The MAC Source Address-based admission control function operating on the selected DPoE ONU port in the upstream direction controls what frames received from DPoE ONU ports are admitted for upstream transmission. When the MAC Source Address-based admission control function is disabled, all frames received from the DPoE

³¹ Revised per OAMv2.0-N-12.0056-1 on 3/12/13 by JB.

ONU port are admitted for upstream transmission. When the MAC Source Address-based admission control function is enabled, the DPoE ONU MUST drop any frame received from the DPOE ONU ports if the MAC Source Address for such a frame is not present in the MAC address admission control table on the DPOE ONU. The said table may be filled through dynamic MAC learning or configured through provisioning.

9.2.7 MAC Learning Min Guarantee (0xD7/0x0107)

Objects: User Port

This attribute represents minimum number of MAC addresses that can be learned on an individual UNI port.

Table 54 - MAC Learning Min Guarantee

Size	Description	Units	Default	Min	Max
2	Minimum guaranteed limit	Entries	40	0	40

9.2.8 MAC Learning Max Allowed (0xD7/0x0108)

Objects: User Port

This attribute represents maximum allowed number of MAC addresses on an individual S₁ port.

Table 55 - MAC Learning Max Allowed

Size	Description	Units	Default	Min	Max
2	Maximum allowed limit	Entries	n/a	0	0xFFFF

9.2.9 MAC Learning Aggregate Limit (0xD7/0x0109)

Objects: D-ONU

This message represents the aggregate dynamic MAC address limit for the D-ONU as a whole. This is the maximum number of addresses that can be learned by all ports combined. Setting the limit to zero disables MAC learning on the D-ONU.

Table 56 - MAC Learning Aggregate Limit

Size	Description	Units	Default	Min	Max
2	The D-ONU aggregate dynamic MAC address limit	Entries	0	0	0xFFFF

9.2.10 Len Error Discard (0xD7/0x010A)

Objects: User Port

This attribute represents the Length Error Discard Enable status of the D-ONU ports. Length errors occur when the layer 2 length does not match the frame length.

Table 57 - Len Error Discard

Size	Description	Units	Default	Min	Max
1	If Length Error Discard Enable 0: Frames with a Length Error will be passed 1: Frames with a Length Error will be discarded	Boolean	1	0	1

9.2.11 Flood Unknown (0xD7/0x010B)

Objects: D-ONU

This message represents the configuration for flooding of downstream frames whose destination addresses have not been learned. Disabling will cause these frames to be discarded.

Table 58 - Flood Unknown

Size	Description	Units	Default	Min	Max
1	Flood Unknown DA option 0: Drop unknown MAC DA 1: Flood unknown MAC DA	Boolean	1	0	1

9.2.12 Local Switching (0xD7/0x010C)

Objects: User Port

This attribute represents the configuration of a port for local switching. With local switching enabled, a port may send traffic to any other user-side port of the D-ONU. This feature should be used with caution for unknown flooding.

Table 59 - Local Switching

Size	Description	Units	Default	Min	Max
1	Local Switching option 0: Disable local switching 1: Enable local switching	Boolean	0	0	1

9.2.13 LLID and Queue Configuration (0xD7/0x010D)³²

Objects: D-ONU

This TLV configures the number of LLIDs to be registered by the given D-ONU. The DPoE System sends this message to change the number of links to be registered, adding or subtracting LLIDs as the network configuration requires. The number of links is bundled together with the configuration of the upstream queues associated with each LLID, as well as the downstream queues on the D-ONU. The upstream queues hold frames destined for the given LLID. The downstream queues hold frames destined for the UNI Ethernet ports. Queue sizes are specified in the order of queue priority, where the first queue associated for the given LLID or port has the highest priority.

The DPoE ONU MUST reject a queue configuration message that changes queue numbers or size for any LLIDs/queues that have port ingress rules that use those queues. The vCM MUST delete all port ingress rules that forward traffic to particular queues before those queues can be deleted (including by removing their LLID) or resized.

Table 60 - LLID and Queue Configuration

Size	Description	Units	Default	Min	Max*
Upstream Configuration					
1	N, the number of LLIDs to configure.		1	1	255
LLID 0 Configuration					
1	M, the number of upstream queues for LLID 0	queues	1	1	8
M	1	Queue 0 Size	4KB	1	-

³² Revised per OAMv2.0-12.0050-1 on 3/12/13 by JB.

Size	Description		Units	Default	Min	Max*
				
	1	Queue M - 1 Size	4KB		1	-
	LLID 1 Configuration					
	...					
	LLID N - 1 Configuration					
Downstream Configuration						
1	P, the number of Ports to configure.				1	-
	Port 0 Configuration (i.e., Ethernet port 1)					
	1	J, the number of downstream queues for Port 0	queues	8	0	8
	J	1	Queue 0 Size	4KB	1	-
				
		1	Queue J - 1 Size	4KB		1
	Port 1 Configuration					
	...					
	Port P - 1 Configuration					
Note						
The Maximum value is subject to available queues. Some of these queues are required by the system for internal use, especially depending on the number of LLIDs to register.						

The message above consists of two configuration sections: Upstream and Downstream. The upstream section of the message specifies LLID configuration. The TU interface port registers one or more LLIDs, and each LLID can be assigned one or more queues. The downstream section specifies UNI port configuration. Each port can be assigned one or more queues. The sum of queue sizes must not exceed the size reported in the Get D-ONU Information.

9.2.14 Firmware Filename (0xD7/0x010E) NVS R³³

Objects: D-ONU

This attribute represents the name of the DPoE ONU firmware file, as obtained by the vCM from the OSS. This attribute is read-only by OAM and is set during the software update process, where the name of the DPoE ONU firmware file is carried in the File Transfer Write Request PDU. The DPoE ONU firmware file name has the format of a null-terminated ASCII string.

9.2.15 MAC Table Full Behavior (0xD7/0x010F)

Objects: User Port

This attribute controls behavior of the D-ONU MAC address learning process when it has reached a limit of MAC addresses, and a new address is discovered. The default behavior is to discard the new address. The alternative is to overwrite the oldest address in the table with the newly discovered address.

Table 61 - MAC Table Full Behavior

Size	Description	Units	Default	Min	Max
1	MAC Table Full option 0: Discard new address 1: Overwrite oldest address	Enumerated	0	0	1

³³ Revised per OAMv2.0-N-12.0056-1 on 3/12/13 by JB.

9.2.16 Multicast LLID (0xD7/0x0110)³⁴

Objects: ONU

See [1904.1A], subclause 14.4.3.2.15.

9.2.17 UNI MAC Learned (0xD7/0x0111)³⁵

Objects: ONU

See [1904.1A], subclause 14.4.3.2.16.

9.2.18 Clear Dynamic MAC Table (0xD9/0x0101)

Objects: D-ONU, User Port

This action clears the dynamically learned MAC addresses table for the object in context, either a particular port, or the D-ONU as a whole (all S₁ ports on the D-ONU).

9.2.19 Add Dynamic MAC Address (0xD9/0x0102)

Objects: User Port

This attribute adds one or more dynamic MAC addresses to the table for the port in context.

Table 62 - Add Dynamic MAC Address

Size	Description	Units	Default	Min	Max
6	MAC address 0	--	-	-	-
...	MAC address 1	-	-	-	-

9.2.20 Delete Dynamic MAC Address (0xD9/0x0103)

Objects: User Port

This attribute deletes one or more dynamic MAC addresses to the table for the port in context. Format is the same as for Add Dynamic MAC Address.

9.2.21 Configure eSAFE (0xD7/0x0116)³⁶

Objects: ONU

Table 63 - Configure eSAFE

Size	Description	Length	Format
varies	eSAFE Configuration File	variable	TLV

This message is used to forward one or more eSAFE-specific TLVs contained in the DOCSIS Configuration file downloaded by the vCM associated with this device.

For example, eSAFEs may be enabled/disabled according to specific eSAFE-defined methods. The example below shows enable/disable for an eRouter.

³⁴ Revised per OAM-N-15.0221-2 on 10/30/15 by JB.

³⁵ Revised per OAM-N-15.0221-2 on 10/30/15 by JB.

³⁶ Added per OAM-N-17.0248-3 on 4/17/17 by JB.

Enable/Disable eRouter

A valid eRouter Initialization Mode Encoding contains exactly one instance of this TLV.

Type	Length	Value
1	1	0: Disabled 1: IPv4 Protocol Enabled 2: IPv6 Protocol Enabled 3: Dual IP Protocol Enabled 4-255: Invalid Default: 3 (Dual IP Protocol Enabled)

Note: If the target ONU does not contain the specified eSAFE, the above configuration is ignored by the ONU.

9.2.22 Enable/Disable eMTA/eDVA (0xD7/0x0117)³⁷

Objects: ONU

Table 64 - Enable/Disable eMTA/eDVA

Size	Description	Length	Format
varies	eMTA/eDVA Enable/Disable	12(IPv4) or 36(IPv6)	vCM DHCP Option 122 sub options 1 and 2 (IPv4)

This message provides the ability to enable or disable an eMTA using the existing DHCP option handling mechanism. The following format and content is required:

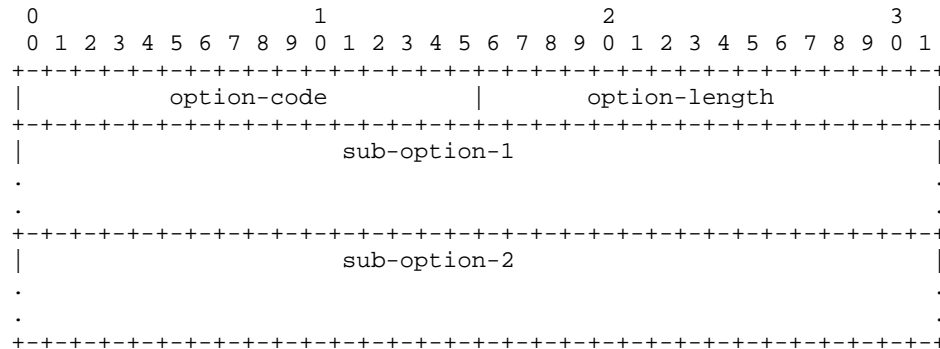

Option-code: 2170 (0x087A) for IPv6 or 0122 (0x007A) for IPv4

Option-length: n (12 for IPv4, 36 for IPv6)

Sub-option-1: The multimedia telephony adapter (MTA) portion of the device listens to this IP address of the DHCP server. This has two special values:

1. All 0's i.e., 0.0.0.0 for IPv4 (which will disable the MTA),
2. All 1's i.e., 255.255.255.255 for IPv4 (which will instruct the MTA to accept replies from any DHCP server).

Sub-option 2: A second DHCP server's IP address. Otherwise the same as sub-option-1.

³⁷ Added per OAM-N-17.0248-3 on 4/17/17 by JB.

9.2.23 Clear Static MAC Table (0xD9/0x0104)

Objects: D-ONU, User Port

This action clears the entire static MAC address table for the object in context, either a particular port, or the D-ONU as a whole (all S₁ ports on the D-ONU).

9.2.24 Add Static MAC Address (0xD9/0x0105)

Objects: User Port

This attribute adds one or more static MAC addresses from the forwarding table for the port in context.

Table 65 - Add Static MAC Address

Size	Description	Units	Default	Min	Max
6	MAC address 0	-	-	-	-
...	MAC address 1	-	-	-	-

9.2.25 Delete Static MAC Address (0xD9/0x0106)

Objects: User Port

This attribute adds one or more static MAC addresses from the forwarding table for the port in context.

Table 66 - Delete Static MAC Address

Size	Description	Units	Default	Min	Max
6	MAC address 0	-	-	-	-
...	MAC address 1	-	-	-	-

9.2.26 Config Multicast LLID (0xD9/0x0107)³⁸

Objects: ONU

See [1904.1A], subclause 14.4.5.2.7.

9.3 Statistics And Counters

Many counter attributes can be used with different object context to provide various granularity on the statistics. For example, a "frames transmitted" counter attribute might be applicable to queues, logical links, or ports. D-ONUs MAY implement the coarser granularity counters by summing over all the finer-grained objects that feed into the coarser ones.

9.3.1 Rx Frames Green (0xD7/0x0201)

Objects: Network Port, User Port, Unicast Logical Link, Multicast Logical Link, Queue

This attribute represents the count of frames received at one port. If color marking is not in use, all received frames are considered "green" frames.

³⁸ Revised per OAM-N-15.0221-2 on 10/30/15 by JB.

Table 67 - Rx Frames Green

Size	Description	Units	Default	Min	Max
8	Frames received at object in context	Frames	-	0	0xFFFF FFFF FFFF FFFF

9.3.2 Tx Frames Green (0xD7/0x0202)

Objects: Network Port, User Port, Unicast Logical Link, Queue

This attribute represents the count of frames transmitted from one port. If color shaping is not in use, all transmitted frames are considered "green" frames.

Table 68 - Tx Frames Green

Size	Description	Units	Default	Min	Max
8	Frames transmitted from object in context	Frames	-	0	0xFFFF FFFF FFFF FFFF

9.3.3 Rx Frame Too Short (0xD7/0x0203)

Objects: Network Port, User Port

This attribute represents RxFrameTooShort counter of one port.

Table 69 - Rx Frame Too Short

Size	Description	Units	Default	Min	Max
8	RxFrameTooShort counter of one port	Frames	-	0	0xFFFF FFFF FFFF FFFF

9.3.4 Rx Frame 64 (0xD7/0x0204)

Objects: Network Port, User Port

This attribute represents RxFrame64 counter of one port.

Table 70 - Rx Frame

Size	Description	Units	Default	Min	Max
8	RxFrame64 counter of one port	Frames	-	0	0xFFFF FFFF FFFF FFFF

9.3.5 Rx Frame 65_127 (0xD7/0x0205)

Objects: Network Port, User Port

This attribute represents RxFrame65_127 counter of one port.

Table 71 - Rx Frame 65_127

Size	Description	Units	Default	Min	Max
8	RxFrame65_127 counter of one port	Frames	-	0	0xFFFF FFFF FFFF FFFF

9.3.6 Rx Frame 128_255 (0xD7/0x0206)

Objects: Network Port, User Port

This attribute represents RxFrame128_255 counter of one port.

Table 72 - Rx Frame 128_255

Size	Description	Units	Default	Min	Max
8	RxFrame128_255 counter of one port	Frames	-	0	0xFFFF FFFF FFFF FFFF

9.3.7 Rx Frame 256_511 (0xD7/0x0207)

Objects: Network Port, User Port

This attribute represents RxFrame256_511 counter of one port.

Table 73 - Rx Frame 256_511

Size	Description	Units	Default	Min	Max
8	RxFrame256_511 counter of one port	Frames	-	0	0xFFFF FFFF FFFF FFFF

9.3.8 Rx Frame 512_1023 (0xD7/0x0208)

Objects: Network Port, User Port

This attribute represents RxFrame512_1023 counter of one port.

Table 74 - Rx Frame 512_1023

Size	Description	Units	Default	Min	Max
8	RxFrame512_1023 counter of one port	Frames	-	0	0xFFFF FFFF FFFF FFFF

9.3.9 Rx Frame 1024_1518 (0xD7/0x0209)

Objects: Network Port, User Port

This attribute represents RxFrame1024_1518 counter of one port.

Table 75 - Rx Frame 1024_1518

Size	Description	Units	Default	Min	Max
8	RxFrame1024_1518 counter of one port	Frames	-	0	0xFFFF FFFF FFFF FFFF

9.3.10 Rx Frame 1519 Plus (0xD7/0x020A)

Objects: Network Port, User Port

This attribute represents RxFrame1519Plus counter of one port.

Table 76 - Rx Frame 1519 Plus

Size	Description	Units	Default	Min	Max
8	RxFrame1519Plus counter of one port	Frames	-	0	0xFFFF FFFF FFFF FFFF

9.3.11 Tx Frame 64 (0xD7/0x020B)

Objects: Network Port, User Port

This attribute represents TxFrame64 counter of one port.

Table 77 - Tx Frame 64

Size	Description	Units	Default	Min	Max
8	TxFrame64 counter of one port	Frames	-	0	0xFFFF FFFF FFFF FFFF

9.3.12 Tx Frame 65_127 (0xD7/0x020C)

Objects: Network Port, User Port

This attribute represents TxFrame65_127 counter of one port.

Table 78 - Tx Frame 65_127

Size	Description	Units	Default	Min	Max
8	TxFrame65_127 counter of one port	Frames	-	0	0xFFFF FFFF FFFF FFFF

9.3.13 Tx Frame 128_255 (0xD7/0x020D)

Objects: Network Port, User Port

This attribute represents TxFrame128_255 counter of one port.

Table 79 - Tx Frame 128_255

Size	Description	Units	Default	Min	Max
8	TxFrame128_255 counter of one port	Frames	-	0	0xFFFF FFFF FFFF FFFF

9.3.14 Tx Frame 256_511 (0xD7/0x020E)

Objects: Network Port, User Port

This attribute represents TxFrame256_511 counter of one port.

Table 80 - Tx Frame 256_511

Size	Description	Units	Default	Min	Max
8	TxFrame256_511 counter of one port	Frames	-	0	0xFFFF FFFF FFFF FFFF

9.3.15 Tx Frame 512_1023 (0xD7/0x020F)

Objects: Network Port, User Port

This attribute represents TxFrame512_1023 counter of one port.

Table 81 - Tx Frame 512_1023

Size	Description	Units	Default	Min	Max
8	TxFrame512_1023 counter of one port	Frames	-	0	0xFFFF FFFF FFFF FFFF

9.3.16 Tx Frame 1024_1518 (0xD7/0x0210)

Objects: Network Port, User Port

This attribute represents TxFrame1024_1518 counter of one port.

Table 82 - Tx Frame 1024_1518

Size	Description	Units	Default	Min	Max
8	TxFrame1024_1518 counter of one port	Frames	-	0	0xFFFF FFFF FFFF FFFF

9.3.17 Tx Frame 1519 Plus (0xD7/0x0211)

Objects: Network Port, User Port

This attribute represents TxFrame1519Plus counter of one port.

Table 83 - Tx Frame 1519 Plus

Size	Description	Units	Default	Min	Max
8	TxFrame1519Plus counter of one port	Frames	-	0	0xFFFF FFFF FFFF FFFF

9.3.18 Queue Delay Threshold (0xD7/0x0212)³⁹

Objects: Queue

This attribute represents Threshold for Delay that causes Bytes Delayed counter to increment for a queue, hereafter referred to as “DelayThreshold”. The current object context is used to identify the queue for which this attribute is relevant.

Table 84 - Queue Delay Threshold

Size	Description	Units	Default	Min	Max
1	QueueDelayThreshold for a queue	100us	0x1E	0	0xFF

9.3.19 Queue Delay (0xD7/0x0213)

Objects: Queue

This attribute represents Maximum Frame Delay experienced since statistic reset for a queue. The current object context is used to identify the queue for which this attribute is relevant.

Table 85 - Queue Delay

Size	Description	Units	Default	Min	Max
8	QueueDelay for a queue	100us	-	0	0xFFFF FFFF FFFF FFFF

9.3.20 Frames Dropped (0xD7/0x0214)

Objects: Queue

³⁹ Revised tables and text 9.3.18 through 9.3.23 and deleted tables and text 9.3.24 - 9.3.28 per OAMv2.0-N-13.0066-2 on 3/13/13 by JB.

This attribute represents the frames dropped due to queue overflow or rate control discard ("red" frames). The current object context is used to identify the queue for which this attribute is relevant..

Table 86 - Frames Dropped

Size	Description	Units	Default	Min	Max
8	FramesDropped counter for a queue	Frames	-	0	0xFFFF FFFF FFFF FFFF

9.3.21 Bytes Dropped (0xD7/0x0215)

Objects: Queue

This attribute represents the bytes dropped due to queue overflow or rate control discard (bytes in "red" frames). The current object context is used to identify the queue for which this attribute is relevant.

Table 87 - Bytes Dropped

Size	Description	Units	Default	Min	Max
8	BytesDropped counter for a queue	bytes	-	0	0xFFFF FFFF FFFF FFFF

9.3.22 Bytes Delayed (0xD7/0x0216)

Objects: Queue

This attribute represents the bytes in frames with a D-ONU queue residency time greater than DelayThreshold for a queue. The current object context is used to identify the queue for which this attribute is relevant.

Table 88 - Bytes Delayed

Size	Description	Units	Default	Min	Max
8	BytesDelayed counter for a queue	bytes	-	0	0xFFFF FFFF FFFF FFFF

9.3.23 Tx Bytes Unused (0xD7/0x0217)

Objects: Unicast Logical Link

This attribute represents the bytes granted to the Unicast Logical Link but not filled with transmitted data.

Table 89 - Tx Bytes Unused

Size	Description	Units	Default	Min	Max
8	TxBytesUnused counter of one LLID	bytes	-	0	0xFFFF FFFF FFFF FFFF

9.3.24 Optical Mon Temperature (0xD7/0x021D)⁴⁰

Objects: Network Port

This attribute represents the current optical module temperature, expressed in the form of a 16 bit signed twos complement value in increments of 1/256 degrees Celsius valid between -40C and +125C.

Table 90 - Optical Mon Temperature

Size	Description	Units	Default	Min	Max
2	Current temperature	1/256 C	-	0x8000	0x7FFF

9.3.25 Optical Mon Vcc (0xD7/0x021E)⁴¹

Objects: Network Port

This attribute represents the current optical module Vcc.

Table 91 - Optical Mon Vcc

Size	Description	Units	Default	Min	Max
2	Current Vcc	100 uV	-	0	0xFFFF

9.3.26 Optical Mon Tx Bias Current (0xD7/0x021F)⁴²

Objects: Network Port

This attribute represents the current optical module Tx bias current.

Table 92 - Optical Mon Tx Bias Current

Size	Description	Units	Default	Min	Max
2	Current Tx bias	2 uA	-	0	0xFFFF

9.3.27 Optical Mon Tx Power (0xD7/0x0220)⁴³

Objects: Network Port

This attribute represents the current optical module Tx power.

Table 93 - Optical Mon Tx Power

Size	Description	Units	Default	Min	Max
2	Current Tx power	0.1uW	-	0	0xFFFF

9.3.28 Optical Mon Rx Power (0xD7/0x0221)⁴⁴

Objects: Network Port

⁴⁰ Revised per OAMv2.0-12.0050-1 on 3/12/13 by JB.

⁴¹ Revised per OAMv2.0-12.0050-1 on 3/12/13 by JB.

⁴² Revised per OAMv2.0-12.0050-1 on 3/12/13 by JB.

⁴³ Revised per OAMv2.0-12.0050-1 on 3/12/13 by JB.

⁴⁴ Revised per OAMv2.0-12.0050-1 on 3/12/13 by JB.

This attribute represents the current optical module Rx power.

Table 94 - Optical Mon Rx Power

Size	Description	Units	Default	Min	Max
2	Current Rx power	0.1uW	-	0	0xFFFF

9.3.29 Rx Frames Yellow (0xD7/0x0222)

Objects: Network Port, User Port, Unicast Logical Link, Multicast Logical Link, Queue

This attribute represents the count of frames received at one port. If color marking is not in use, this value is zero.

Table 95 - Rx Frames Yellow

Size	Description	Units	Default	Min	Max
8	Frames received at object in context	Frames	-	0	0xFFFF FFFF FFFF FFFF

9.3.30 Tx Frames Yellow (0xD7/0x0223)

Objects: Network Port, User Port, Unicast Logical Link, Queue

This attribute represents the count of frames transmitted from one port. If color shaping is not in use, all transmitted frames are considered "green" frames.

Table 96 - Tx FramesYellow

Size	Description	Units	Default	Min	Max
8	Frames transmitted from object in context	Frames	-	0	0xFFFF FFFF FFFF FFFF

9.3.31 Tx Bytes Green (0xD7/0x0224)

Objects: Network Port, User Port, Unicast Logical Link, Queue

This attribute represents the count of bytes in green frames transmitted from one port. If color shaping is not in use, all transmitted frames are considered "green" frames.

Table 97 - Tx Bytes Green

Size	Description	Units	Default	Min	Max
8	Frames transmitted from object in context	Frames	-	0	0xFFFF FFFF FFFF FFFF

9.3.32 Rx Bytes Yellow (0xD7/0x0225)

Objects: Network Port, User Port, Unicast Logical Link, Multicast Logical Link,, Queue

This attribute represents the count of bytes in yellow frames received at one port. If color shaping is not in use, this value is zero.

9.3.33 Rx Bytes Green (0xD7/0x0226)

Objects: Network Port, User Port, Unicast Logical Link, Multicast Logical Link, Queue

This attribute represents the count of bytes in green frames received at one port. If color shaping is not in use, all received frames are considered "green" frames.

Table 98 - Tx Bytes Green

Size	Description	Units	Default	Min	Max
8	Frames transmitted from object in context	Frames	-	0	0xFFFF FFFF FFFF FFFF

9.3.34 Tx Bytes Yellow (0xD7/0x0227)

Objects: Network Port, User Port, Unicast Logical Link, Queue

This attribute represents the count of bytes in yellow frames transmitted from one port. If color shaping is not in use, this value is zero.

Table 99 - Tx Bytes Yellow

Size	Description	Units	Default	Min	Max
8	Frames transmitted from object in context	Frames	-	0	0xFFFF FFFF FFFF FFFF

9.3.35 Tx Frames Unicast (0xD7/0x0228)

Objects: Network Port, User Port

This attribute represents the count of frames transmitted with a unicast L2 DA.

Table 100 - Tx Frames Unicast

Size	Description	Units	Default	Min	Max
8	Frames transmitted from object in context	Frames	-	0	0xFFFF FFFF FFFF FFFF

9.3.36 Tx Frames Multicast (0xD7/0x0229)

Objects: Network Port, User Port

This attribute represents the count frames transmitted with a multicast L2 DA (bit 40 set).

Table 101 - Tx Frames Multicast

Size	Description	Units	Default	Min	Max
8	Frames transmitted from object in context	Frames	-	0	0xFFFF FFFF FFFF FFFF

9.3.37 Tx Frames Broadcast (0xD7/0x022A)

Objects: Network Port, User Port

This attribute represents the count of frames transmitted with the broadcast L2 DA (all 1s).

Table 102 - Tx Frames Broadcast

Size	Description	Units	Default	Min	Max
8	Frames transmitted from object in context	Frames	-	0	0xFFFF FFFF FFFF FFFF

9.3.38 Rx Frames Unicast (0xD7/0x022B)

Objects: Network Port, User Port

This attribute represents the count frames received with a L2 unicast DA (bit 40 = 0).

Table 103 - Rx Frames Unicast

Size	Description	Units	Default	Min	Max
8	Frames received at object in context	Frames	-	0	0xFFFF FFFF FFFF FFFF

9.3.39 Rx Frames Multicast (0xD7/0x022C)

Objects: Network Port, User Port

This attribute represents the count of frames received with a multicast L2 DA (bit 40 set).

Table 104 - Rx Frames Multicast

Size	Description	Units	Default	Min	Max
8	Frames received at object in context	Frames	-	0	0xFFFF FFFF FFFF FFFF

9.3.40 Rx Frames Broadcast (0xD7/0x022D)

Objects: Network Port, User Port

This attribute represents the count of frames received with the broadcast L2 DA (all 1s).

Table 105 - Rx Frames Broadcast

Size	Description	Units	Default	Min	Max
8	Frames received at object in context	Frames	-	0	0xFFFF FFFF FFFF FFFF

9.3.41 Number of Programmable Counters (0xD7/0x022E) R

Objects: D-ONU

This capabilities attribute indicates the number of programmable frame/byte counters supported by the D-ONU hardware.

9.3.42 L2CP Frames Rx (0xD7/0x022F)⁴⁵

Objects: Network Port, User Port

Number of layer 2 control protocol frames received.

Table 106 - L2CP Frames Rx

Size	Description	Units	Default	Min	Max
8	L2CP frames received at object in context	Frames	-	0	0xFFFF FFFF FFFF FFFF

9.3.43 L2CP Octets Rx (0xD7/0x0230)

Objects: Network Port, User Port

Number of octets in layer 2 control protocol frames received.

⁴⁵ Revised and added new tables to 9.3.47 - 9.3.54 per OAMv2.0-12.0050-1 on 3/12/13 by JB.

Table 107 - L2CP Octets Rx

Size	Description	Units	Default	Min	Max
8	Octets in L2CP frames received at object in context	Octets	-	0	0xFFFF FFFF FFFF FFFF

9.3.44 L2CP Frames Tx (0xD7/0x0231)

Objects: Network Port, User Port

Number of layer 2 control protocol frames transmitted.

Table 108 - L2CP Frames Tx

Size	Description	Units	Default	Min	Max
8	L2CP frames transmitted at object in context	Frames	-	0	0xFFFF FFFF FFFF FFFF

9.3.45 L2CP Octets Tx (0xD7/0x0232)

Objects: Network Port, User Port

Number of octets in layer 2 control protocol frames transmitted.

Table 109 - L2CP Octets Tx

Size	Description	Units	Default	Min	Max
8	Octets in L2CP frames transmitted at object in context	Octets	-	0	0xFFFF FFFF FFFF FFFF

9.3.46 L2CP Frames Discarded (0xD7/0x0233)

Objects: Network Port, User Port

Number of layer 2 control protocol frames discarded (because the D-ONU was configured to discard those protocols, rather than tunnel or peer them).

Table 110 - L2CP Frames Discarded

Size	Description	Units	Default	Min	Max
8	L2CP frames discarded at object in context	Frames	-	0	0xFFFF FFFF FFFF FFFF

9.3.47 L2CP Octets Discarded (0xD7/0x0234)

Objects: Network Port, User Port

Number of octets in layer 2 control protocol frames discarded (because the D-ONU was configured to discard those protocols, rather than tunnel or peer them).

Table 111 - L2CP Octets Discarded

Size	Description	Units	Default	Min	Max
8	Octets in L2CP frames discarded at object in context	Octets	-	0	0xFFFF FFFF FFFF FFFF

9.3.48 Tx L2 Errors (0xD7/0x0235)

Objects: Network Port, User Port

Number of frames that failed to transmit because of an error in the data link layer (too many collisions, etc.).

Table 112 - Tx L2 Errors

Size	Description	Units	Default	Min	Max
8	L2 frames discarded at object in context in the transmit direction	Frames	-	0	0xFFFF FFFF FFFF FFFF

9.3.49 Rx L2 Errors (0xD7/0x0236)

Objects: Network Port, User Port

Number of received frames discarded due to errors in the frame (FCS errors, length errors, etc.).

Table 113 - Rx L2 Errors

Size	Description	Units	Default	Min	Max
8	L2 frames discarded at object in context in the receive direction	Frames	-	0	0xFFFF FFFF FFFF FFFF

9.3.50 Clear Counters (0xD9/0x0201)

Objects: D-ONU

This action clears all statistics counters for the D-ONU.

9.3.51 Programmable Frame/Byte Counter (0xD8/nnnn) R⁴⁶

Objects: D-ONU

There are a maximum of 32,768 programmable counter attributes, "Programmable Counter 0" through "Programmable Counter 32767". The 0xD8 branch indicates a programmable counter; the leaf code indicates the exact counter. Programmable counters count both bytes and frames. The leaf codes of a frame counter and the corresponding byte counter are related; the frame counter with leaf code I corresponds to the byte counter with leaf code I + 0x8000.

The programmable counter index for the frame counter (0..32767) is used as the parameter for the Increment Counter rule result. The rule result increments both the frame and byte counters for frames that match the rule condition.

9.4 Alarms

Alarms are indicated by the D-ONU to the DPoE System using DPoE Event Notification TLVs in an [802.3] Clause 57 Event Notification PDU.

9.4.1 Port Stat Threshold (0xD7/0x0301)

Objects: Network Port, User Port

⁴⁶ Revised per OAMv2.0-15.0229-1 on 2/11/16 by JB.

This attribute allows the OAM client to specify an alarm to be generated when a port statistics counter exceeds a certain value at the end of a 1-second sampling period. A rising threshold and a falling threshold (high-water mark and low-water mark) are provided to allow hysteresis. The alarm condition will occur when the statistic is greater than or equal to the rising threshold. The alarm condition will be cleared when the statistic is less than or equal to the falling threshold. A value of 0 for the rising threshold means that the alarm is disabled.

Table 114 - Port Stat Threshold

Size	Description	Units	Default	Min	Max
3	Statistic Attribute branch/leaf	-	-	0	0xFF FFFF
4	Rising Threshold (to set alarm; 0 disables the alarm)	As stat	-	0	0xFFFF FFFF
4	Falling Threshold (to clear alarm)	As stat	-	0	0xFFFF FFFF

9.4.2 Link Stat Threshold (0xD7/0x0302)

Objects: Unicast Logical Link, Multicast Logical Link

This attribute allows the OAM client to specify an alarm to be generated when a Unicast Logical Link statistics counter exceeds a certain value at the end of a 1-second sampling period. A rising threshold and a falling threshold (high-water mark and low-water mark) are provided to allow hysteresis. The alarm condition will occur when the statistic is greater than or equal to the rising threshold. The alarm condition will be cleared when the statistic is less than or equal to the falling threshold. A value of 0 for the rising threshold means that the alarm is disabled.

Table 115 - Link Stat Threshold

Size	Description	Units	Default	Min	Max
3	Statistic Attribute Branch/Leaf	-	-	0	0xFF FFFF
4	Rising Threshold (to set alarm; 0 disables the alarm)	As stat	-	0	0xFFFF FFFF
4	Falling Threshold (to clear alarm)	As stat	-	0	0xFFFF FFFF

9.4.3 Suspend/Resume Alarm Reporting (0xD7/0x0303)⁴⁷

Objects: D-ONU, User Port, PON Port, Queue, Unicast Logical Link, Multicast Logical Link

This attribute allows the DPoE System to enable or disable transmission of alarm messages generated by the given context object. An enabled alarm behaves normally per the definition for that alarm. While an alarm is disabled, a D-ONU MUST NOT signal this alarm in an Event Notification TLV. Alarms can be disabled on a per-object basis. The object is specified using the Object Context TLV. A single Suspend/Resume Alarm Reporting message carries a total of N alarm status information tuples, where each alarm is described by the (Event Code, Enabled/Disabled) tuple, as shown in Table 116. Only Event Codes that are relevant to the object context should be included in the message. Attempting to enable or disable an alarm message which is not relevant to the associated object context will result in an error..

Table 116 - Alarm Enable

Size	Description	Units	Default	Min	Max
1	Event Code(0)	See Table 14	-	0	0xFF
1	Enabled /Disabled [0] (Enabled=1, Disabled=0)	Boolean	0	0	1
...
1	Event Code [N-1]	See Table 14	-	0	0xFF
1	Enabled/Disabled [N-1]	Boolean	0	0	1

⁴⁷ Revised text and table per OAMv2.0-N-12.0059-2 on 3/13/13 by JB.

When the Suspend/Resume Alarm attribute (0xD7/0x0303) is carried in the Get Response eOAMPDU, it contains the (Event Code, Enabled/Disabled) tuple for all defined alarm codes listed in Table 14 that are relevant for the current object context.

9.4.4 Retrieve Current Alarm Summary (0xD9/0x0301)

Objects: D-ONU

This action directs the D-ONU to send a report of all currently raised alarm conditions. To report, the D-ONU generates a series of one or more Event Notification PDUs containing DPoE Alarm TLVs corresponding to all current alarm conditions at the D-ONU.

9.5 Security

Security attributes control encryption on the EPON. Details of encryption methods and their use can be found in [DPoE-SECv2.0].

9.5.1 Encryption Key Expiry Time (0xD7/0x0401)

Objects: Unicast Logical Link

This attribute represents the timeout value for encryption keys. A new key will be generated and exchanged periodically, as this timer expires. A timeout value of 0 is used to disable security (i.e., encryption). The minimum non-zero value should be at least 10 seconds.

Table 117 - Encryption Key Expiry Time

Size	Description	Units	Default	Min	Max
2	Timeout value	sec	0	0/10	0xFFFF

9.5.2 Encryption Mode (0xD7/0x0402)

Objects: Unicast Logical Link

This attribute sets the encryption method to be used on a particular logical link. Details of encryption methods are defined in [DPoE-SECv2.0].

Table 118 - Encryption Mode

Size	Description	Units	Default	Min	Max
1	Encryption Method 0: None 1: 1Down 2: 10Down 3: 10Bi	enum	0	0	3

9.6 Frame Processing

9.6.1 Port Ingress Rule (0xD7/0x0501)

Objects: Network Port, User Port

This attribute represents a rule in the ingress table of the current port. A single rule, which can be complex and larger than the 128-byte contents of a single TLV, is represented in an OAM frame as a series of TLVs with this attribute code. The first byte of the attribute is always a subtype indicator, which indicates the structure of the rest of the TLV contents.

A single rule is represented by a sequential series of Port Ingress Rule TLVs, which must start with one Header subtype, then one or more Clause subtype TLVs, then one or more Result subtype TLVs, and finally end with a Terminator subtype. For each rule, DPoE System MUST include one Header subtype, one or more Clause subtypes, one or more Result subtypes, and end with the Terminator subtype. Similarly, for each rule, D-ONU MUST include one Header subtype, one or more Clause subtypes, one or more Result subtypes, and end with the Terminator subtype.

The entire table of rules for a port would be represented as a large attribute, and thus include one or more Header/Clause/Result/Terminator sequences, ultimately terminated by a zero-length container with the Port Ingress Rule attribute value.

Table 119 - Rule Attribute Subtypes

Field Value	Name	Description
0	Terminator	Indicates end of one individual rule
1	Header	Information which pertains to the entire rule
2	Clause	One single clause of the rule condition; all clauses are ANDed together to form the condition that determines whether the rule matches
3	Result	One single result that occurs if the rule condition is true

9.6.1.1 Rule Attribute – Terminator Subtype

The terminator subtype indicates the end of a single rule. There are no further contents in the body of this subtype.

9.6.1.2 Rule Attribute – Header Subtype

All rules begin with a Rule attribute of the Header subtype.

Table 120 - Rule Attribute Header Subtype

Size	Name	Description
1	Subtype	Header (01)
1	Precedence	Precedence of the rule (0x00..0xFF)
Note: 0x00 is considered the highest rule precedence value, and 0xFF the lowest. Note that is the reverse of the order in the DOCSIS config file TLVs; the DPoE System inverts the precedence range when constructing DPoE OAM rules from those TLVs.		

9.6.1.3 Rule Attribute – Clause Subtype

Rule clauses define the condition that must evaluate to true for the rule to match a frame. All clauses of a rule are evaluated and the individual results ANDed together to determine the match condition. An individual clause is a binary operation which relates a field in the frame with a constant match value via a binary operator.

Table 121 - Rule Attribute Clause Subtype

Size	Name	Description
1	Subtype	Clause (02)
1	Field Code	Code representing the field of the frame for this clause; see Table 122.
1	Field Instance	Which instance of a field identified by code (if there is more than one)
1	MSB Mask	Bits to ignore on the most significant side of the field
1	LSB Mask	Bits to ignore on the least significant side of the field
1	Operator	Binary operator for this rule
1	Match Value Length	Number of bytes of Match Value to follow
varies	Match Value	Constant value combined with field value via the binary operator for this clause

Some fields, such as VLAN tags, occur in multiple instances in some frames. To distinguish two such fields, a Field Instance is used in conjunction with the Field Code. Instances of such fields are numbered starting from 0 in the order in which they are transmitted in the frame. So, for example, C-VLAN tag 0 would be the outermost tag in a frame, immediately after the addresses, with two C-VLAN tags, with C-VLAN tag 1 being the inner tag, closer to the payload of the frame.

The most-significant- and least-significant-bits masks are used to reduce the number of field codes and provide flexibility for frame processing rules. A VLAN tag, for instance, is coded as one field. Commonly, however, rules might be interested in just the Tag Protocol Identifier (TPID), just the Class of Service (CoS), or just the VID portions of this field. A rule can compare these subfields by using the MSB and LSB masks to isolate the sub-field of interest. Similarly, the IPv4 TOS field is 8 bits wide, but the same bits are interpreted as IP Precedence (upper three bits) or DSCP. Any of these interpretations can be accommodated with the single IPv4 TOS field and the proper masks. Refer to Appendix IV for examples of sub-field identifiers for rule definition. Note that the I-Tag field is considered in Link OAM to be 48 bits in length, which deviates from [802.1ah] because it does not include the Customer Destination or Source MAC address.

The match value is a variable-length field, always an integral number of octets wide. Values are right-aligned in this field, occupying the least significant bits.

Since IPv4 and IPv6 headers have similar semantics, and a single frame can only be one or the other, but not both, of these types, some field codes are re-used for the IP equivalents like the addresses or priority fields. Rule sets that need to treat the same field differently based on protocol should use the EtherType field to distinguish IPv4 from IPv6.

Table 122 - Field Codes⁴⁸

Value (hex)	Description	Multiple?
0x00	LLID Index (Note 2)	N
0x01	L2 Destination MAC address	N
0x02	L2 Source MAC address	N
0x03	L2 Type/Len	N
0x04	B-DA ([802.1ah])	N
0x05	B-SA ([802.1ah])	N
0x06	I-Tag ([802.1ah])	N
0x07	S-VLAN Tag	Y
0x08	C-VLAN Tag	Y
0x09	MPLS Label Stacking Entry (LSE)	Y
0x0A	IPv4 TOS/IPv6 Traffic Class	N
0x0B	IPv4 TTL/IPv6 Hop Limit	N
0x0C	IPv4/IPv6 Protocol Type (Note 3)	N
0x0D	IPv4 Source Address	N
0x0E	IPv6 Source Address	N
0x0F	IPv4 Destination Address	N
0x10	IPv6 Destination Address	N
0x11	IPv6 Next Header	Y* (Note 1)
0x12	IPv6 Flow Label	N
0x13	TCP/UDP source port	N
0x14	TCP/UDP destination port	N
0x15	B-Tag ([802.1ah])	N
0x16	Reserved	-

⁴⁸ Revised per OAMv2.0-N-13.0062-1 on 3/13/13 by JB. Revised per OAM-N-15.0221-2 on 10/30/15 by JB.

Value (hex)	Description	Multiple?
0x17	Reserved	-
0x18	Custom field 0	N
0x19	Custom field 1	N
0x1A	Custom field 2	N
0x1B	Custom field 3	N
0x1C	Custom field 4	N
0x1D	Custom field 5	N
0x1E	Custom field 6	N
0x1F	Custom field 7	N
0x20	Reserved for DPoG specifications	N
0x21	LLID Value (Note 4)	N

Note 1:
IPv6 extension headers are instantiated in the sense that there can be a variable number of them. However, they are not ordered in a frame. The instance number for this field is not the usual 0..N-1th instance of an instantiated field, but is instead the Next Header value for that header type assigned by the IANA.

Note 2:
LLID Index represents the local index of the logical link instantiated on the DPoE ONU. For example, for a DPoE ONU supporting 8 LLIDs, the value of LLID Index would range from 0 to 7. In this way, the LLID Index has only local, DPoE ONU specific meaning. The LLID Index matches the LLID in order of the link MAC address. That is, LLID Index 0 on a particular DPOE ONU is the LLID with the numerically lowest MAC address on that DPOE ONU; LLID Index 1 is the next higher MAC address, and so on.

Note 3:
IPv6 Protocol Type represents the Next Header field of the last extension header in the chain, which might contain any number of optional extension headers..

Note 4:
Valid LLID values are defined in [802.3], 76.2.6.1.3.2.

Table 123 - Rule Operators

Field Value	Symbol	Description
0	F	Never match
1	==	Field equal to value
2	!=	Field not equal to value
3	<=	Field less than or equal to value
4	>=	Field greater than or equal to value
5	exists	True if field exists (value ignored)
6	!exist	True if field does not exist (value ignored)
7	T	Always match

9.6.1.4 Rule Attribute – Result Subtype

Rule results represent the processing performed on a frame when the frame matches the rule condition.

Table 124 - Rule Attribute Result Subtype

Size	Name	Description
1	Subtype	Result (03)
1	Rule Result	Rule Result (see Table 125)
varies	Result Parameters	Rule Result Parameters, as defined for each result

Table 125 - Rule Results

Code (hex)	Name	Description	Parameter Len	Parameter
0x00	NOP	No operation	0	
0x01	Discard	Set Discard Flag for Frame	0	
0x02	Forward	Clear Discard Flag for Frame (Forward Frame)	0	
0x03	Queue	Set destination queue for frame	4	{object type, object instance, queue number}, as in Section 8.7.5
0x04	Set	Set output field	4+ n	Field to set; n bytes of value
0x05	Copy	Copy output field	4	Field to set from field used in last clause of rule
0x06	Delete	Delete field	2	Field Code to remove from frame
0x07	Insert	Insert field	2	Field Code to insert into frame
0x08	Replace	Delete field and Insert current output field	2	Field Code to replace
0x09	Clear Delete	Do not delete field (override other Delete result)	2	Field Code not to delete
0x0A	Clear Insert	Do not insert field (override other Insert result)	2	Field Code not to insert
0x0B	Increment Counter	Increments programmable counter for frames that match this rule, and bytes in those frames	2	Index for programmable counter to increment

9.6.1.4.1 NOP

The NOP result has no net effect, and does not affect the state of the frame. It can be useful as a placeholder result.

9.6.1.4.2 Discard

Frames are considered to be associated with a "discard" flag. If the discard flag is true after all rule processing, the frame will be discarded. This result sets the discard flag to true.

9.6.1.4.3 Forward

The Forward result sets the discard flag for a frame to false. The frame will be forwarded. (See the Queue result, Section 9.6.1.4.4.)

9.6.1.4.4 Queue

The Queue result sets the destination queue for a frame. A queue is specified as a {object type, object instance, queue number} tuple as defined in Section 8.7.5. Only TU interface ports have LLIDs. The object type indicates whether the port is a LLID or User Port, and uses the same values as the Object Context. Note that this parameter has the same format as the Queue Object defined in Section 8.7.5. (See Table 27 - Queue Object).

9.6.1.4.5 Set

The Set result sets the value of an output field for the frame. The result takes as parameters the field descriptor to set, followed by the value for that field. Bits protected by the Mask values are not modified by the Set operation. This feature allows setting just part of a field; for example, just the PCP bits in a VLAN tag. Values for fields that are not an integral multiple of eight bits wide are right-justified in the parameter value, and are padded with zeros on the left (most significant) bits.

Table 126 - Set Parameters

Size	Name	Description
1	Field Code	Field code to set
1	Field Instance	Field Instance to set
1	MSB Mask	Number of most significant bits not to modify
1	LSB Mask	Number of least significant bits not to modify
varies	Value	New value for output field

9.6.1.4.6 Copy

The Copy result copies the value of some field into the specified output field. The source field is the field used in the last clause of the rule condition. Typically this result is used to copy priority fields, such as IP TOS to [802.1Q] CoS bits, or to copy an inner VLAN tag to an outer one. Bits of the output field protected by the Mask values are not modified by the Copy operation.

Table 127 - Copy Parameters

Size	Name	Description
1	Field Code	Field code to set
1	Field Instance	Field Instance to set
1	MSB Mask	Number of most significant bits not to modify
1	LSB Mask	Number of least significant bits not to modify

9.6.1.4.7 Delete

This result marks a field of a frame to be deleted. If the Delete flag is set after all rules have been processed, the deleted field will not be present in a forwarded frame. This result is commonly used to remove VLAN tags or other encapsulation from a frame. Note that it is not possible to delete just part of a field with "Mask" bits similar to some other field syntax.

Table 128 - Delete Parameters

Size	Name	Description
1	Field Code	Field Code to delete
1	Field Instance	Field Instance to delete

9.6.1.4.8 Insert

The Insert result adds a field to a frame. If the Insert flag is set after all rules have been processed, the output field will be added to the frame. The value of the field normally will be Set by some other rule result. The default value for a field that did not exist in the frame is all zeroes. This result is commonly used to add VLAN tags or other encapsulation to a frame.

Table 129 - Insert Parameters

Size	Name	Description
1	Field Code	Field Code to insert
1	Field Instance	Field Instance to insert

9.6.1.4.9 Replace

Replace combines the Insert and Delete results into a single operation for convenience, resulting in overwriting a field of a frame with a new value. This result is commonly used to translate priority values or VLAN tag values.

Table 130 - Replace Parameters

Size	Name	Description
1	Field Code	Field Code to replace
1	Field Instance	Field Instance to replace

9.6.1.4.10 Clear Delete

This result clears the Delete flag for a field, reversing the decision of a lower precedence rule to delete the given field.

Table 131 - Clear Delete Parameters

Size	Name	Description
1	Field Code	Field Code to keep
1	Field Instance	Field Instance to keep

9.6.1.4.11 Clear Insert

This result clears the Insert flag for a field, reversing the decision of a lower precedence rule to insert the given field.

Table 132 - Clear Insert Parameters

Size	Name	Description
1	Field Code	Field Code not to insert
1	Field Instance	Field Instance not to insert

9.6.2 Custom Field (0xD7/0x0502)

Objects: Network Port, User Port

This attribute represents the fields parsed from each frame that are used in frame processing rules to filter or classify the frames.

Each D-ONU port contains a table of ingress rules that are applied to the frames received on the port. Each field is programmed with a field code. The code describes the field parsed from the frame in terms of protocol layer, dword in the frame, bit start, and bit width.

Table 133 - Custom Field

Size	Description	Units	Default	Min	Max
1	Field Code (see Table 120)	enum	-	18	0x1F
1	Layer select	See Table 134	-	0	8
1	32-bit word offset	32-bit words	-	0	8
1	Least significant bit (bit offset)	Bits	-	0	31
1	Bit width	Bits	-	1	32
1	Reference Count	Number of clauses	-	0	255

The Reference Count indicates the number of clauses in rules that are currently using this field. If the field is currently unused, the Reference Count will be zero. When this is the case, the Layer Select, Dword offset, Least significant bit, and Bit width fields will contain the maximum possible values.

Fields with a non-zero Reference Count cannot be reprogrammed with the Set PDU. All rules using a given field must be deleted, reducing the reference count to zero, before the meaning of that field is changed.

The Reference Count field is ignored in Set messages, and should be set to zero by the transmitter.

Table 134 - Custom Field Layer Values⁴⁹

Layer Value	Name	Description
0x0	Preamble/L2	LLID, DA, SA, SNAP headers (if present)
0x1	Preamble/[802.1ah]	LLID, B-DA, B-SA, I-Tag
0x2	EtherType	L2 protocol type of remainder of the frame
0x3	S-VLAN Tags	All S-VLAN tags in the frame
0x4	C-VLAN Tags	All C-VLAN tags in the frame
0x5	MPLS LSEs	MPLS LSEs, if any, in the frame
0x6	IPv4	Frames with EtherType 0800
0x7	IPv6	Frames with EtherType 86DD
0x8	Generic L3	Payload of a frame that is not IPv4 or IPv6, according to the EtherType
0x9	TCP/UDP	IPv4 or IPv6 frames containing UDP or TCP (according to the IP protocol type field)
0xA	Generic L4	Payload of IP frames that is not TCP or UDP

9.6.2.1 Preamble/L2 Header

The preamble/L2 layer consists of the LLID and L2 Ethernet header fields of the received frame. This layer also contains the SNAP headers if they are present. Figure 7 shows the offsets within this layer when the frame does not have SNAP encapsulation.

3	3	2	2	2	2	2	2	2	2	2	2	1	1	1	1	1	1	1	1	1	1	9	8	7	6	5	4	3	2	1	0
Reserved (Unknown)										LLID Value										Reserved											
Reserved (Always 0)										L2 DA [47:32]																					
L2 DA [31:0]																															
L2 SA [47:16]																															
L2 SA [15:0]										L2 Type Field [15:0]																					

Figure 7 - Preamble/L2 without SNAP

Figure 8 shows the offsets into this layer when the frame has SNAP encapsulation.

3	3	2	2	2	2	2	2	2	2	2	2	2	1	1	1	1	1	1	1	1	1	1	9	8	7	6	5	4	3	2	1	0
Reserved (Unknown)										LLID Value										Reserved												
Reserved (Always 0)										L2 DA [47:32]																						
L2 DA [31:0]																																
L2 SA [47:16]																																
L2 SA [15:0]										L2 Length Field [15:0]																						
DSAP [7:0]					SSAP [7:0]					CTL [7:0]					OUI [23:16]																	
OUI [15:0]										L2 Type Field [15:0]																						

Figure 8 - Preamble/L2 with SNAP

⁴⁹ Revised table per OAMv2.0-N-13.0062-1 on 3/13/13 by JB.

9.6.2.2 [802.1ah]

The [802.1ah] layer consists of the [802.1ah] "MAC-in-MAC" encapsulation header, including the B-DA, B-SA, and I-Tag fields. This layer exists only in [802.1ah] encapsulated frames, as determined by the presence of the I-Tag (a TPID value of 0x88E7 immediately following the SA).

3	3	2	2	2	2	2	2	2	2	2	2	1	1	1	1	1	1	1	1	1	9	8	7	6	5	4	3	2	1	0
Reserved (Unknown)										LLID Value										Reserved										
Reserved (Always 0)																B-DA [47:32]														
B- DA [31:0]																														
B-SA [47:16]																														
B- SA [15:0]										I-Tag TPID																				
Reserved (Always 0)										I-SID																				

Figure 9 - [802.1ah] Layer

9.6.2.3 EtherType

The EtherType layer consists only of the 16-bit EtherType value, wherever it may be located in the source frame. Note that a Length value in an [802.3] format frame is not considered an EtherType value. Ethernet II versus [802.3] format can be tested by testing the existence of the EtherType.

3	3	2	2	2	2	2	2	2	2	2	2	1	1	1	1	1	1	1	1	1	9	8	7	6	5	4	3	2	1	0
Reserved (Unknown)																Layer 2 EtherType														

Figure 10 - EtherType Layer

9.6.2.4 S-VLAN Tags

The S-VLAN tag layers consist of all S-VLAN tags identified in the frame. An S-VLAN tag is defined by the TPID seen by the parser, which includes the [802.1ad] value 0x88A8 as well as the additional S-VLAN TPID value, if that value has been defined.

3	3	2	2	2	2	2	2	2	2	2	2	1	1	1	1	1	1	1	1	1	9	8	7	6	5	4	3	2	1	0	
TPID 0										PRI			C	VID 0																	
TPID 1										PRI			C	VID 1																	
TPID 2										PRI			C	VID 2																	
...																															

Figure 11 - S-VLAN Layer

9.6.2.5 C-VLAN Tags

The C-VLAN tag layers consist of all C-VLAN tags identified in the frame. A "C-VLAN tag" is defined by the TPID seen by the parser, which includes the [802.1Q] value 0x8100, as well as the Additional C-VLAN TPID value, if that value has been defined.

3 1	3 0	2 9	2 8	2 7	2 6	2 5	2 4	2 3	2 2	2 1	2 0	1 9	1 8	1 7	1 6	1 5	1 4	1 3	1 2	1 1	1 0	9	8	7	6	5	4	3	2	1	0
TPID 0												PRI		C	VID 0																
TPID 1												PRI		C	VID 1																
TPID 2												PRI		C	VID 2																
...																															

Figure 12 - C-VLAN Layer

9.6.2.6 MPLS LSEs⁵⁰

The MPLS LSEs layer consists of all MPLS LSEs identified in the frame, including the Label, Traffic Class (TC), Bottom of the Stack (S), and Time to Live (TTL) fields present in the given MPLS LSE instance, as defined in [RFC 5462].

3 1	3 0	2 9	2 8	2 7	2 6	2 5	2 4	2 3	2 2	2 1	2 0	1 9	1 8	1 7	1 6	1 5	1 4	1 3	1 2	1 1	1 0	9	8	7	6	5	4	3	2	1	0
Label 0												TC 0		S	TTL 0																
Label 1												TC 1		S	TTL 1																
Label 2												TC 2		S	TTL 2																

Figure 13 - MPLS LSEs Layer

9.6.2.7 IPv4

The IPv4 layer only exists in frames with EtherType 0x0800, and consists of the 40 bytes of standard IPv4 header, followed by any IPv4 options. Note the bit ordering in this layer is consistent with the other layers in this specification, but is the reverse of IETF documentation.

3 1	3 0	2 9	2 8	2 7	2 6	2 5	2 4	2 3	2 2	2 1	2 0	1 9	1 8	1 7	1 6	1 5	1 4	1 3	1 2	1 1	1 0	9	8	7	6	5	4	3	2	1	0
Version		Hdr Len		Type of Service				Length of datagram																							
Identification												Flags		Fragment Offset																	
Time to Live				Protocol				Header Checksum																							
Source IP Address																															
Destination IP Address																															
IP Options (if any) ...																															

Figure 14 - IPv4 Layer

9.6.2.8 IPv6

The IPv6 layer only exists in frames with EtherType 0x86DD, and consists of the 40 bytes of base IPv6 header, followed by extension headers. Note the bit ordering in this layer is consistent with the other layers in this specification, but is the reverse of IETF documentation.

⁵⁰ Revised text and table per OAMv2.0-N-13.0062-1 on 3/13/13 by JB.

3	3	2	2	2	2	2	2	2	2	2	1	1	1	1	1	1	1	1	1	1	9	8	7	6	5	4	3	2	1	0	
1	0	9	8	7	6	5	4	3	2	1	0	9	8	7	6	5	4	3	2	1	0										
Version		Traffic Class					Flow Label																								
Payload Length										Next Header										Hop Limit											
Source Address																															
Source Address																															
Source Address																															
Source Address																															
Destination Address																															
Destination Address																															
Destination Address																															
Destination Address																															

Figure 15 - IPv6 Layer

9.6.2.9 Generic L3

The Generic L3 layer consists of all bytes after the VLAN or MPLS layers in frames that are not IP frames; that is, those frames with EtherType other than 0x0800 or 0x86DD. Rules that match custom fields in the Generic L3 layer likely need also to match the EtherType to ensure that the frame contains the expected protocol.

9.6.2.10 TCP/UDP

The TCP/UDP layer consists of the bytes of the standard TCP or UDP header, if the frame is an IP frame (v4 or v6), and if the IP Protocol type indicates UDP or TCP.

3	3	2	2	2	2	2	2	2	2	2	1	1	1	1	1	1	1	1	1	1	9	8	7	6	5	4	3	2	1	0	
1	0	9	8	7	6	5	4	3	2	1	0	9	8	7	6	5	4	3	2	1	0										
Source Port										Destination Port																					

Figure 16 - Layer TCP/UDP

9.6.2.11 Generic L4

The Generic L4 layer consists of all bytes after the IP header (v4 or v6) if the IP protocol type is not UDP and not TCP. Rules that match custom fields in the Generic L4 layer likely need also to match the IP protocol type field to ensure that the frame contains the expected protocol.

9.6.3 C-VLAN TPID (0xD7/0x0503)

Objects: Network Port, User Port

This attribute represents an alternate EtherType value that is used to identify a C-VLAN tag in a frame, in addition to the standard IEEE value of 0x8100. D-ONUs with an alternate C-VLAN TPID will accept either the alternate value or 0x8100 as indicating a C-VLAN tag. C-VLAN tags added by a D-ONU are always added with the standard value of 0x8100 by default. If the "Insert This TPID" field is set to TRUE (1), then this alternate TPID will be used for all tags inserted by the D-ONU instead.

Table 135 - C-VLAN TPID

Size	Description	Units	Default	Min	Max
2	Alternate C-VLAN TPID	-	0x8100	0	0xFFFF
1	Insert This TPID	Boolean	0	0	1

9.6.4 S-VLAN TPID (0xD7/0x0504)

Objects: Network Port, User Port

This attribute represents an alternate EtherType value that is used to identify an S-VLAN tag in a frame, in addition to the standard IEEE value of 0x88A8. D-ONUs with an alternate S-VLAN TPID will accept either the alternate value or 0x88A8 as indicating an S-VLAN tag. VLAN tags added by a D-ONU are always added with the standard value of 0x88A8 by default. If the "Insert This TPID" field is set to TRUE (1), then this alternate TPID will be used for all tags inserted by the D-ONU instead.

Table 136 - S-VLAN TPID

Size	Description	Units	Default	Min	Max
2	Alternate S-VLAN TPID		0x88A8	0	0xFFFF
1	Insert This TPID	Boolean	0	0	1

9.6.5 Reserved (0xD7/0x0505)⁵¹

9.6.6 I-TPID (0xD7/0x0506)

Objects: Network Port, User Port

This attribute represents an alternate I-TPID value that is used to identify an I-Tag in a frame, in addition to the value of 0x88E7 as defined in [802.1Q]. D-ONUs with an alternate I-TPID will accept either the alternate value or 0x88E7 as indicating an I-Tag. I-Tags added by a D-ONU are always added with the standard value of 0x88E7 by default. If the "Insert This TPID" field is set to TRUE (1), then this alternate I-TPID will be used for all I-Tags inserted by the D-ONU instead.

Table 137 - I-TPID

Size	Description	Units	Default	Min	Max
2	Alternate I-TPID		0x88E7	0	0xFFFF
1	Insert This TPID	Boolean	0	0	1

9.6.7 B-TPID (0xD7/0x0507)

Objects: Network Port, User Port

This attribute represents an alternate EtherType value that is used to identify a B-Tag in a frame, in addition to the value of 0x88A8 as defined in [802.1Q]. D-ONUs with an alternate B-TPID will accept either the alternate value or 0x88A8 as indicating a B-Tag. B-Tags added by a D-ONU are always added with the standard value of 0x88A8 by default. If the "Insert This TPID" field is set to TRUE (1), then this alternate B-TPID will be used for all B-Tags inserted by the D-ONU instead.

Table 138 - B-TPID

Size	Description	Units	Default	Min	Max
2	Alternate B-TPID		0x88A8	0	0xFFFF
1	Insert This TPID	Boolean	0	0	1

⁵¹ Revised per OAM-N-15.0221-2 on 10/30/15 by JB.

9.6.8 Clear Port Ingress Rules (0xD9/0x0501)

Objects: Network Port, User Port

This action deletes all ingress frame processing rules of the current port.

9.6.9 Add Port Ingress Rule (0xD9/0x0502)

Objects: Network Port, User Port

This action adds the Port Ingress Rule, which preceded this TLV to the port in context.

9.6.10 Delete Port Ingress Rule (0xD9/0x0503)

Objects: Network Port, User Port

This action deletes the Port Ingress Rule, which preceded this TLV to the port in context.

9.7 Service Level Agreements

9.7.1 Broadcast Rate Limit (0xD7/0x0601)⁵²

Objects: User Port

This attribute represents a limit on the number of broadcast frames that can be received through the Ethernet interface. The rates refer to packet counts in a second. Once the count is exceeded, the discard result will be set for the packet at precedence 1. D-ONU rules can override the discard with a forward result at higher precedence. When set to 0xFF-FF-FF-FF, the broadcast rate filtering is disabled.

Table 139 - Broadcast Rate Limit

Size	Description	Units	Default	Min	Max
4	The maximum number of broadcast packets allowed from context user port in 1 second.	packets / second	20 0000	0	0xFF-FF-FF-FF

9.7.2 Obsolete (0xD7/0x0602)

This attribute is deprecated in DPoEv2.0.

9.7.3 Obsolete (0xD7/0x0603)

This attribute is deprecated in DPoEv2.0.

9.7.4 Queue Committed Information Rate (0xD7/0x0604)

Objects: Queue

This attribute represents the CIR rate for output from a queue.

Table 140 - Queue CIR

Size	Description	Units	Default	Min	Max
2	Committed Burst Size (0 to disable)	256 Bytes	0	0	0xFFFF
4	Committed Information Rate	1 Kbps	0	0	0xFFFF FFFF

⁵² Revised per OAMv2.0-12.0050-1 on 3/12/13 by JB.

9.7.5 FEC Mode (0xD7/0x0605)⁵³

Objects: Network Port, Unicast Logical Link, Multicast Logical Link

This attribute represents the current FEC mode.

For any PX type device, operating at the effective data rate of 1 Gbit/s in downstream and upstream directions, the upstream and downstream links support values as shown in Table 128, both for reading and writing.

For any PRX type device, operating at the effective data rate of 10 Gbit/s downstream and 1 Gbit/s upstream, the upstream link supports values as shown in Table 141 for the “The D-ONU tx/upstream FEC” attribute, while the downstream link supports only the value “FEC is ON” for the “The D-ONU rx/downstream FEC” attribute. On read, the ONU returns the value of “FEC is ON” for the “The D-ONU tx/upstream FEC” attribute. Any attempt to write any value other than “FEC is ON” into the “The D-ONU rx/downstream FEC” attribute is ignored.

For any PR type device, operating at the effective data rate of 10 Gbit/s in downstream and upstream directions, only the value “FEC is ON” is supported for both downstream and upstream links. On read, the ONU returns the value of “FEC is ON” for the “The D-ONU rx/downstream FEC” attribute and the “The D-ONU tx/upstream FEC” attribute. Any attempt to write any value other than “FEC is ON” into the “The D-ONU rx/downstream FEC” attribute and the “The D-ONU tx/upstream FEC” attribute is ignored.

If the object context is the Multicast Logical Link, “The D-ONU tx/upstream FEC” attribute should be ignored at the reception at both the D-ONU and DPoE System.

Table 141 - FEC Mode

Size	Description	Units	Default	Min	Max
1	The D-ONU rx/downstream FEC 0: Off – No FEC 1: On – FEC is ON	enum	0	0	1
1	The D-ONU tx/upstream FEC 0: Off – No FEC 1: On – FEC is ON	enum	0	0	1

9.7.6 Queue Excess Information Rate (0xD7/0x0606)

Objects: Queue

This attribute represents the EIR rate for output from a queue.

Table 142 - Queue EIR

Size	Description	Units	Default	Min	Max
2	Excess Burst Size (0 to disable)	256 Bytes	0	0	0xFFFF
4	Queue EIR	1 Kbps	0	0	0xFFFF FFFF

9.7.7 Queue Color Marking (0xD7/0x0607)

Objects: Queue

This attribute represents the method of marking frames according to particular shaper results, usually described as "color" values. When color marking is enabled, the field indicated in this attribute will be overwritten before frame egress with the green or yellow color value according to the rate limiter results for that frame.

⁵³ Revised per OAMv2.0-N-12.0052-1 on 3/12/13 by JB.

Table 143 - Queue Color Marking

Size	Description	Units	Default	Min	Max
1	Enable Color Marking	Boolean	0	0	1
1	Field Code	(See Table 122)	0	0	0xFF
1	Field Instance		0	0	0xFF
1	MSB Mask		0	0	0xFF
1	LSB Mask		0	0	0xFF
1	Green Value		0	0	0xFF
1	Yellow Value		0	0	0xFF

9.7.8 Queue Rate Limiter Capabilities (0xD7/0x0608) R

Objects: D-ONU

This capabilities attribute describes support for the rate limiting function in the D-ONU hardware. The "Number of Rate Limiters" fields indicates how many instances of hardware exist; that is, how many different services can be independently controlled with this feature. A value of 0 indicates the feature is not supported.

"Min Increments" for rate limits indicate the smallest multiple of the field units (256 bytes / 1Kbps) which can actually be enforced. For example, hardware that can rate limit only to multiples of 64 Kbps would have a CIR Min Increment of 64.

"Color Aware?" indicates whether the function is sensitive to incoming color marking. "Coupling Configurable?" indicates whether the CIR+EIR coupling behavior for yellow frames can be changed. When Coupling Configurable? is FALSE, "Coupling Behavior Default" indicates the coupling behavior that is always present. "Color Marking Support?" indicates whether the hardware can alter egress frames to show the results from the rate limiter function. "Smart Color Drop?" indicates whether the hardware is capable of considering the color of a frame when making decisions to drop frames from a queue.

Table 144 - Queue Rate Limiter Capabilities

Size	Description	Units	Default	Min	Max
2	Number of Rate Limiters	Instances	0	0	0xFF FF
2	CBS Min Increment	256 bytes	1	0	0xFF FF
2	CIR Min Increment	1K bps	1	0	0xFF FF
2	EBS Min Increment	256 bytes	1	0	0xFF FF
2	EIR Min Increment	1K bytes	1	0	0xFF FF
1	Color Aware?	Boolean	0	0	1
1	Coupling Configurable?	Boolean	0	0	1
1	Coupling Behavior Default	Boolean	0	0	1
1	Color Marking Support?	Boolean	0	0	1
1	Smart Color Drop?	Boolean	0	0	1

9.7.9 Coupling Flag (0xD7/0x0609)

Objects: Queue

Indicates the value of the MEF coupling flag for joint behavior of the CIR/EIR shapers.

Table 145 - Coupling Flag

Size	Description	Units	Default	Min	Max
1	Coupling Flag	Boolean	0	0	1

9.7.10 Enable User Traffic (0xD9/0x0601)

Objects: D-ONU, Unicast Logical Link

Enable user data traffic for the object in context. If the object is Unicast Logical Link, this enables user traffic for the link only. If the object is D-ONU, traffic for all logical links is enabled. The Disable User Traffic message stops this traffic. D-ONUs boot with user data traffic disabled. If a link deregisters and then re-registers, the traffic is disabled.

9.7.11 Disable User Traffic (0xD9/0x0602)

Objects: D-ONU, Unicast Logical Link

The Disable message causes the D-ONU to disable all user data traffic for the object in context. If the object is Unicast Logical Link, this disables user traffic for the link only. If the object is D-ONU, traffic for all logical links is disabled OAM and MPCP traffic remains intact. The Enable User Traffic message restores the user traffic. D-ONUs boot with user traffic disabled. If a link deregisters and then re-registers, the traffic is disabled.

9.7.12 Loopback Enable (0xD9/0x0603)

Objects: Unicast Logical Link, User Port

The D-ONU MUST implement logical link loopback as per [802.3]. The D-ONU implements loopback at the S₁ interface using this action.

This attribute enables MAC or PHY loopback at the specified D-ONU S₁ interface (port). Figure 17 below is an example of Set Loopback for a D-ONU S₁ interface (port). When a D-ONU S₁ interface (port) is in loopback, packets sent upstream to the UNI port will be dropped. Packets sent downstream are looped back upstream and transmitted out the TU interface port of the D-ONU. Traffic flowing to other ports will not be affected. This loopback message tests a path through the entire D-ONU, in contrast to the [802.3] link loopback, which occurs at the TU interface side of the D-ONU.

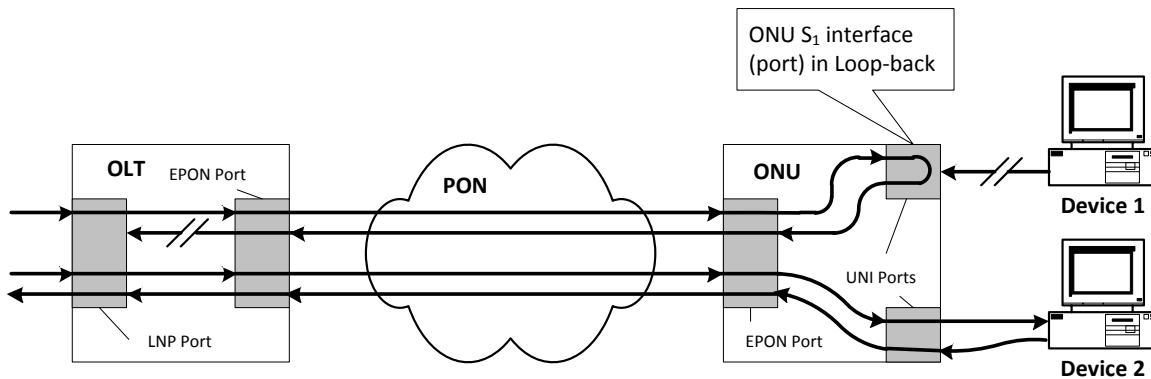

Figure 17 - Set Loopback for D-ONU S₁ Interface

Table 146 - Loopback Enable

Size	Description	Units	Default	Min	Max
1	Location (0 = PHY, 1 = MAC, 2 = unicast logical link)		0	0	2

9.7.13 Loopback Disable (0xD9/0x0604)

Objects: Unicast Logical Link, User Port

This attribute takes the specified entity out of loopback. If the given entity is not in loopback, this message is ignored.

Table 147 - Loopback Disable⁵⁴

Size	Description	Units	Default	Min	Max
1	Location (0 = PHY, 1 = MAC, 2 = logical link)	enum	0	0	2

The procedure for initiating a loopback is to send an Enable Loopback command with the port label of the port on which the loopback is to be established. After the loopback has been set, an autonomous loopback alarm message will be sent to the host. In accordance with [802.3] Clause 57, the DPoE System will start a countdown timer with the value from the Get Loopback Timeout Host Interface message. If the loopback is not cleared by the Host within the period specified (Scenario 1 in Figure 18 below), the Loopback will be cleared automatically by the DPoE System (Scenario 2 in Figure 18 below). An autonomous alarm report will then be sent to the host, indicating that the loopback has been cleared.

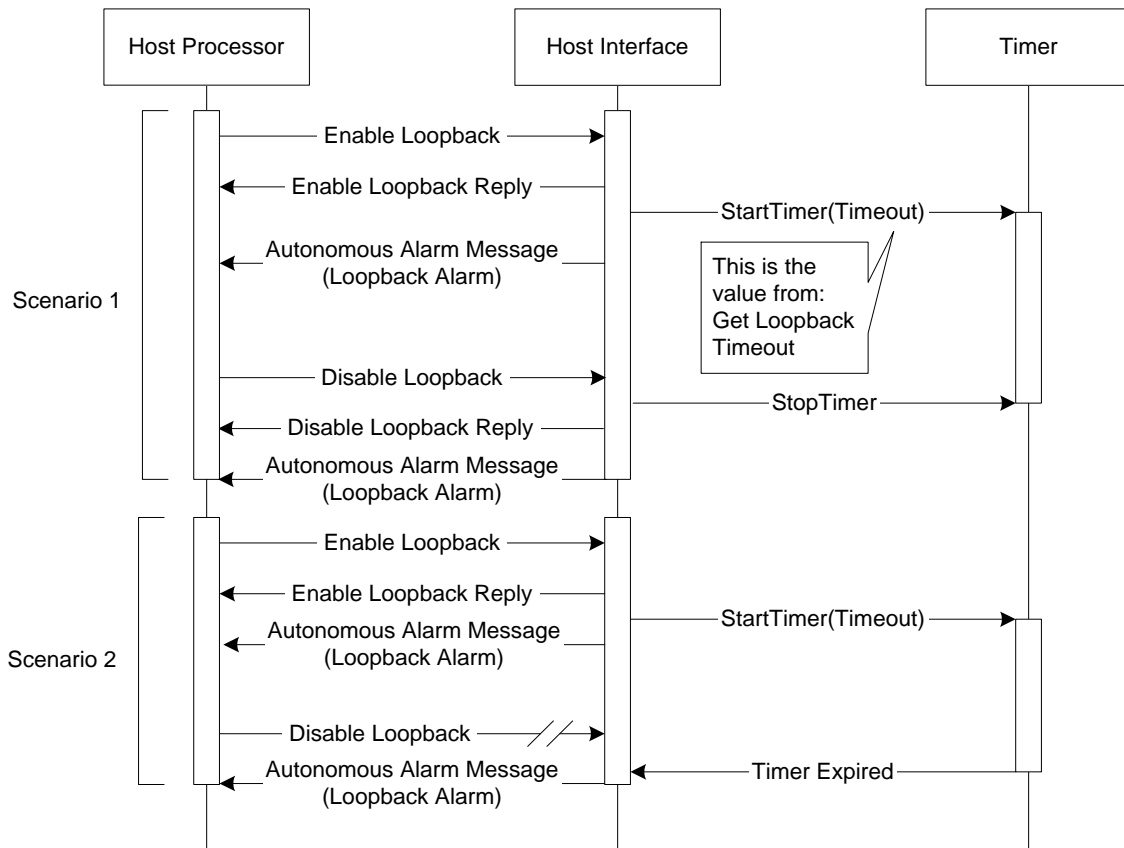

Figure 18 - Enable/Disable Loopback

⁵⁴ Revised per OAMv2.0-N014.0173-1 on 7/18/14 by JB.

9.7.14 Laser Tx Power Off (0xD9/0x0605)

Objects: Network Port

This attribute turns off the laser Tx for specified time for diagnostic purposes. Note that this message can also instruct a D-ONU to permanently remove itself from the network. Setting the power off time to 0 enables the laser power again, bringing an D-ONU back onto the network without waiting for an earlier timer to expire.

Table 148 - Laser Tx Power Off⁵⁵

Size	Description	Units	Default	Min	Max
2	Disable time	milliseconds	-	0 (turn laser on)	0xFFFF (disable permanently)

9.8 Clock Transport⁵⁶

9.8.1 Clock Transport Capabilities (0xD7/0x0701) R

Objects: User Port

This attribute represents the capability of the given user port on the D-ONU to support the 1PPS+TOD or [1588v2] timing interfaces.

Table 149 - Clock Transport Capabilities

Size	Description	Units	Default	Min	Max
1	1PPS Pulse Support	Boolean	0 (unsupported)	0	1
1	TOD String Support	Boolean	0 (unsupported)	0	1
1	[1588v2] Frame Support	Boolean	0 (unsupported)	0	1

9.8.2 Enable Clock Transport (0xD7/0x0702)

Objects: User Port

This attribute enables the selected type of clock transport interface on the given user port on the D-ONU.

Table 150 - Clock Transport Enable

Size	Description	Units	Default	Min	Max
1	1PPS Pulse Output	Boolean	0 (disabled)	0	1
1	TOD String Output	Boolean	0 (disabled)	0	1
1	[1588v2] Frame Output	Boolean	0 (disabled)	0	1

9.8.3 Time Transfer (0xD7/0x0703)⁵⁷

Objects: D-ONU

If at least one [1588v2] interface is enabled on the D-ONU, this attribute sets the time for the next ToD synchronization event on the D-ONU, indicating a reference MPCP clock time and the ToD value when the local D-ONU MPCP clock reaches the value carried in the 'MPCP Reference Point' field.

⁵⁵ Revised per OAMv2.0-N-15.0218-1 on 10/30/15 by JB.

⁵⁶ Revised sections 9.8.1 - 9.8.5 per OAMv2.0-N-13.0074-1 on 6/17/13 by JB.

⁵⁷ Revised per OAMv2.0-12.0050-1 on 3/12/13 by JB.

When at least one 1PPS+TOD interface is enabled on the D-ONU, this attribute sets the MPCP time for the next 1PPS pulse for the clock transport function. The value carried in the 'MPCP Reference Point' is the time for the next 1PPS pulse. The value carried in the 'TOD String' field represents the reference TOD value at the time of the 1PPS pulse. This value is variable length binary data, and may contain embedded NULs (ASCII 0) or other non-printable ASCII, depending on the TOD format in use for the particular DPoE Network.

Table 151 - Time Transfer

Size	Description	Units	Default	Min	Max
4	MPCP Reference Point	16 ns TQ	-	0	0xFFFF FFFF
Varies	TOD String	-	-	-	-

9.8.4 Propagation Parameters (0xD7/0x0704)

Objects: D-ONU

These values represent the refractive index of the fiber connected to this D-ONU in the upstream and downstream wavelengths, multiplied by the coefficient of 2^{24} . (That is, there is an implied radix point after the most significant 8 bits of this value.)

Table 152 - Propagation Parameters

Size	Description	Units	Default	Min	Max
4	ndown	dimensionless	0x01999999	0	0xFFFF FFFF
4	nup	dimensionless	0x01999999	0	0xFFFF FFFF

9.8.5 RTT (0xD7/0x0705)

Objects: D-ONU

This attribute represents the latest value of the round-trip time (RTT) measured by the DPoE System for the given D-ONU, using the mechanisms defined in [802.3] for EPON.

Table 153 - RTT

Size	Description	Units	Default	Min	Max
4	RTT	16 ns TQ	-	0	0xFFFF FFFF

9.9 DEMARC Automatic Configuration⁵⁸

This functionality is no longer defined.

9.9.1 Reserved (0xD7/0x0800)

9.9.2 Reserved (0xD7/0x0801)

9.9.3 Reserved (0xD7/0x0802)

9.9.4 Reserved (0xD7/0x0803)

9.10 UNI management⁵⁹

⁵⁸ Revised per OAMv2.0-N-15.0229-1 on 2/11/16 by JB.

9.10.1 Energy Efficient Ethernet (EEE) status (0xD7/0x0820)

Objects: User Port

This attribute allows the operator to control the status of the Energy Efficient Ethernet (EEE) function on the given UNI port. When the auto-negotiation function on the given UNI port is enabled, setting the EEE status to *enabled* or *disabled* does not have any effect.

Table 154 - EEE Status

Size	Description	Default	Min	Max	Values
1	EEE status	0x00	0x00	0xFF	0x00 = disabled (default) 0x01 = enabled 0x02 – 0xFF = reserved

9.10.2 Power over Ethernet (PoE) status (0xD7/0x0821)

Objects: User Port

This attribute allows the operator to control the status of the Power over Ethernet (PoE) function on the given UNI port. Setting the status of the PoE function on the UNI that does not support PoE has no effect on the operation of the given UNI.

Table 155 - PoE Status

Size	Description	Default	Min	Max	Values
1	PoE status	0x00	0x00	0xFF	0x00 = disabled 0x01 = enabled (default) 0x02 – 0xFF = reserved

9.10.3 Media Type (0xD7/0x0822)

Objects: User Port

This attribute allows the operator to control the type of media used on a selectable-media port. Setting the media type on a UNI port that does not support selectable-media has no effect on the operation of the given UNI.

Table 156 - Media Type

Size	Description	Default	Min	Max	Values
1	Media Type	0x01	0x00	0xFF	0x00 = SFP media 0x01 = BASE-T media (default) 0x02 – 0xFF = reserved

9.11 Optical Link Protection R⁶⁰

9.11.1 ONU Protection Capability (0xD7/0x09-00)

See [1904.1A], subclause 14.4.3.9.1.

⁵⁹ Revised per OAMv2.0-O-14.0122-1 on 2/25/14 by JB.

⁶⁰ Revised per OAMv2.0-15.0224-1 and OAMv2.0-15.0229-1 on 2/11/16 by JB.

9.11.2 ONU Protection Configuration (0xD7/0x09-01)

See [1904.1A], subclause 14.4.3.9.2.

9.11.3 PON Interface Administrative (0xD7/0x09-02)

See [1904.1A], subclause 14.4.3.9.3.

9.11.4 ONU Config Holdover Period (0xD7/0x09-03)

See [1904.1A], subclause 14.4.3.9.4.

9.12 Power Saving⁶¹**9.12.1 ONU Power Saving Capabilities aOnuPwrSavingCap (0xD7/0xFFFF)**

See [1904.1A], subclause 14.4.3.8.1.

⁶¹ Revised per OAMv2.0-N-14.0199-1 on 11/20/14 by JB.

10 MULTICAST LOGICAL LINK REGISTRATION⁶²

DPoE multicast architecture defined in IEEE [1904.1A], TBD Pending SIEPON finalizing 1904.1A update.

⁶² Revised per OAMv2.0-N-14.0143-1 and OAMv2.0-N-14.0154-1 on 5/30/14 by JB. Revised per OAMv2.0-N.14.0173-1 and 14.0192-1 on 7/18/14 by JB. Revised per OAM-N-15.0221-2 on 10/30/15 by JB.

11 SECURITY

See the [DPoE-SECv2.0] document for details of encryption, key exchange, authentication, and other requirements related to security and authentication.

11.1 Key Exchange

DPoE OAM extensions include a key exchange protocol. This can be used to synchronize keys between the DPoE System and D-ONU. The Key Exchange PDU begins with a subtype code to distinguish PDU types used in the key exchange protocol.

The Key Assignment PDU is used to transmit a key value to the network peer.

Table 157 - Key Assignment

Width (Octets)	Field	Value (hex)
1	Key Exchange Subtype	0: Key Assignment
2	LLID	LLID value, as in frame preamble, for the logical link to which this message applies
1	Key Number	0..1; indicates key phase
1	Key Length	Number of bytes of key data (16 for 128-bit AES)
Varies	Key	Random data equal to Length bytes. The first byte is the most significant byte of key data.

The Key Assignment Acknowledgement PDU is sent in some applications of the protocol after a Key Assignment PDU is received.

Table 158 - Key Assignment Ack

Width (Octets)	Field	Value (hex)
1	Key Exchange Subtype	1: Key Assignment Acknowledgement
2	LLID	LLID value, as in frame preamble, for the logical link to which this message applies
1	Key Number	0..1; indicates key phase

12 FILE TRANSFER

DPoE extensions enable D-ONUs to download new firmware upgrades and other files from the DPoE System using a simple file transfer protocol.

This protocol is a simplified form of TFTP. It has been modified to operate over the [802.3] OAM channel instead of IP. This protocol differs from TFTP in the following ways:

- It includes support for only one data encoding option (binary).
- It supports variable sized frames, to suit the negotiated length of the Ethernet OAM frame and take advantage of the longer MTU.
- It acknowledges next block to receive rather than last block received, to avoid the Sorcerer's Apprentice problem without extra timers.
- It replaces the file pathname string with a numeric file type identifier.

To maximize interoperability, the contents of D-ONU files are considered to be opaque to the DPoE System and management system. There is intentionally no standardized header that all D-ONU models must support. An EMS might well add headers to binary files for D-ONUs for its own purposes of storage and tracking, but these headers would be removed before sending the data to the D-ONU. Conversely, any information which a particular D-ONU needs for its own purposes for storage and validation must be included in the D-ONU file; the exact format of this data is up to the D-ONU vendor so long as the file format meets the requirements of this section. The DPoE System does not parse into the contents of files for the D-ONU, but only acts as a gateway to transfer the files.

12.1 File Transfer PDU Header

File Transfer PDUs have a common header, shown below.

Table 159 - File Transfer PDU Header⁶³

Width (Octets)	Field	Value (hex)
6	Ethernet DA	0x01:80:C2:00:00:02 ([802.3] OAM multicast address)
6	Ethernet SA	As per sending MAC
2	Ethernet Type	0x8809 (Ethernet Slow Protocol)
1	Subtype	0x03 ([802.3] OAM)
2	Flags	As per [802.3]
1	Opcode	FE (Vendor extended)
3	OUI	0x001000 (DPoE EPON)
1	DPoE Opcode	0x09 (File Transfer)
1	File Transfer Opcode	See Table 160
varies	File Transfer PDU body	As per each PDU type, defined below

Table 160 - File Transfer PDU Opcodes

File Transfer PDU Opcode	Value (hex)
Reserved	0x0
Write Request	0x1
File Transfer Data	0x2
File Transfer Ack	0x3

⁶³ Revised per OAMv2.0-N014.0173-1 on 7/18/14 by JB.

12.1.1 File Transfer Write Request⁶⁴

The File Transfer Write Request OAM PDUs indicates a request to initiate a file transfer from the DPoE System to the D-ONU, including the target DPoE ONU firmware file name, transferred in the format of a null-terminated ASCII string.. The recipient prepares to receive a file.

The response to a File Transfer Request is a File Transfer Ack message. The error code of the Ack is either zero (Ok), allowing the transfer to proceed, or non-zero, indicating the reason that the transfer cannot take place.

Table 161 - File Transfer Write Request

Width (Octets)	Field	Value (hex)
varies	OSS Filename	Null-terminated ASCII string

12.1.2 File Transfer Data

File Transfer Data PDUs contain the data for the current file. Each PDU carries a sequence number and size field, specifying the number of file data bytes to follow. Data PDUs are sent one block at a time in sequential order. Each block is acknowledged by the recipient before the next block is sent. (This is a "stop and wait" protocol.) The first block of a file has sequence number 0.

The response to a Transfer Request is a File Transfer Ack message. The error code of the Ack is either zero (Ok), allowing the transfer to proceed, or non-zero, indicating the reason that the transfer was aborted. The Ack also contains the block number of the next block the recipient expects to receive.

Once the file transfer begins, at least one Data PDU must be sent every second. If the recipient fails to receive a Data PDU every second, a timeout is counted and the recipient sends a File Transfer Ack. This message contains the timeout error code and the sequence number indicating the desired block. Three successive timeouts will abort the file transfer process. In this case, the file on the recipient is unchanged.

A Data PDU may be sent with a size of zero. This resets the block reception timer on the recipient to prevent a timeout. It does not advance the block sequence number or the state of the received file. This feature can be used to keep a transfer alive in the event of an unanticipated delay at the sender.

Table 162 - File Transfer Data

Width (Octets)	Field	Value (hex)
2	Block Number	Increments
2	Block Width (Octets)	Varies
(Size)	File data	Varies

12.1.3 File Transfer Ack

The Acknowledgement PDUs contain a sequence number and an error code. The sequence number is the number of the next block expected by the recipient. The error code indicates the status of the transfer. A non-zero error code aborts the file transfer and leaves the files on the recipient unchanged.

To signal the end of a file transfer, the sender sends an Ack PDU. This PDU contains sequence number 0 and a code indicating the status of the transfer. (The transfer status indicated is assessed by the sender, not the recipient.) A zero status instructs the recipient to commit the file to permanent storage. A non-zero status instructs the recipient to discard the file, even if the transfer appears successful to the recipient. This Ack is the only Ack sent by the sender in this protocol.

⁶⁴ Revised per OAMv2.0-N-12.0056-1on 3/12/13 by JB.

The final Ack from the sender is acknowledged by a final Ack from the recipient. The recipient sends the Ack after it has committed the file or discarded it. Committing a file to flash requires more time than processing a single data frame. Therefore, the timeout for the final Ack response from the recipient should be at least 15 seconds.

Table 163 - File Transfer Ack

Width (Octets)	Field	Value (hex)
2	Block Number	Increments
1	Response Code	As per File Acknowledgement Response Code table, below

Table 164 - File Acknowledgement Response Code

Ack Response Code	Meaning	Value (hex)
OK	No errors	0x0
Undefined	Unknown error, or one not covered elsewhere	0x1
Not Found	Read requested file that is not available	0x2
No Access	Access permissions do not allow the requested read/write	0x3
Full	Storage is full, and cannot hold the written file	0x4
Illegal Operation	Cannot perform requested operation in current state	0x5
Unknown ID	Requested file ID is not supported by this device	0x6
Bad Block	Block received in error	0x7
Timeout	No block received before timer expiration	0x8
Busy	Cannot perform requested action due to other activity	0x9
Incompatible File	Received file is incompatible with this device. File incompatibility is determined by the device vendor.	0xA
Corrupted File	File was received corrupted and is unusable by this device. File integrity is determined by the device vendor.	0xB

Appendix I Branch/Leaf Code Reference (Informative)

I.1 [802.3] Clause 30 Attributes (Branch 0x07)

The following table lists attributes as defined in [802.3] Clause 30. They are repeated here for ease of reference. These attributes can also appear in DPoE OAM PDUs to avoid the need to send separate PDUs to query both [802.3] and DPoE attributes.

Table 165 - [802.3] Clause 30 Attributes (Branch 07)

Leaf (HEX)	Attribute	Read/ Write	Description
MAC			
0x00 01	MAC ID	R	ID for this MAC in this device
0x00 02	Frames Tx OK	R	Frames transmitted
0x00 03	Single Collision Frames	R	Frames suffering a single collision
0x00 04	Multiple Collision Frames	R	Frames suffering multiple collisions
0x00 05	Frames Rx OK	R	Frames received with no errors
0x00 06	FCS Err	R	Frames received with FCS errors
0x00 07	Alignment Error	R	Alignment errors
0x00 08	Octets Tx OK	R	Octets transmitted in frames with no errors
0x00 09	Frames Deferred	R	Deferred due to collisions
0x00 0A	Late Collisions	R	Collisions after frame in progress
0x00 0B	Excessive Collisions	R	Frames dropped due to too many collisions
0x00 0C	Lost MAC Tx Err	R	Frames lost due to MAC transmission error
0x00 0E	Octets Rx OK	R	Octets received in good frames
0x00 0F	Frames Lost MAC Rx Error	R	Frames lost due to MAC receive error
0x00 12	Multicast Frames Tx	R	Frames transmitted with a multicast address
0x00 13	Broadcast Frames Tx	R	Frames transmitted with a broadcast address
0x00 14	Frames Excessive Deferral	R	Frames dropped due to too many backoff retries
0x00 15	Multicast Frames Rx	R	Frames received with multicast address
0x00 16	Broadcast Frames Rx	R	Frames received with broadcast address
0x00 17	In Range Length Error	R	[802.3] format frames received with actual length not equal to length field
0x00 18	Out of Range Length Error	R	Frames received out of allowed length (short or long)
0x00 19	Frame Too Long	R	Frames received longer than the maximum permitted
0x00 1A	MAC Enable Status	R/W	Port enabled or disabled
0x00 1D	MAC Address	R	MAC Address of the port
0x00 1E	MAC Collision Frames	R	Number of collisions detected by MAC
PHY			
0x00 20	PHY Type	R	Type of PHY for this port
0x00 23	PHY Symbol Err During Carrier	R	Transmission errors detected
0x00 25	PHY Admin State	R/W	PHY enabled or disabled
MAU			
0x00 47	MAU Media Available	R	
Auto-negotiation			
0x00 4E	Auto Neg ID	R	
0x00 4F	Auto Neg Admin State	R/W	
0x00 50	Auto Neg Remote Signal	R	

Leaf (HEX)	Attribute	Read/ Write	Description
0x00 51	Auto Neg Config	R	
0x00 52	Auto Neg Local Tech	R/W	
0x00 53	Auto Neg Advertised Tech	R/W	
0x00 54	Auto Neg Rx Tech	R	
0x00 55	Auto Neg Local Select	R	
0x00 56	Auto Neg Advert Select	R	
0x00 57	Auto Neg Rx Select	R	
MAC			
0x00 5A	Duplex Status	R/W	
MAC Control			
0x00 5D	MAC Ctrl Functions Supported	R	
0x00 5E	MAC Ctrl Frames Tx	R	
0x00 5F	MAC Ctrl Frames Rx	R	
0x00 60	MAC Ctrl Unsupported Op Rx	R	
0x00 61	MAC Ctrl Pause Delay	R	
0x00 62	MAC Ctrl Pause Tx	R	
0x00 63	MAC Ctrl Pause Rx	R	
OMP Emulation			
0x01 18	MPCP Frames Tx	R	
0x01 19	MPCP Frames Rx	R	
0x01 20	MPCP Tx Discovery	R	
0x01 22	MPCP Disc Timeout	R	
FEC			
0x01 24	FEC Corrected Blocks	R	
0x01 25	FEC Uncorrectable Blocks	R	
0x01 39	FEC Ability	R/W	
0x01 3A	FEC Mode	R/W	
OMP Emulation			
0x01 3B	MPCP Tx Gate	R	
0x01 3C	MPCP Tx Reg Ack	R	
0x01 3D	MPCP Tx Register	R	
0x01 3E	MPCP Tx Reg Req	R	
0x01 3F	MPCP Tx Report	R	
0x01 40	MPCP Rx Gate	R	
0x01 41	MPCP Rx Reg Ack	R	
0x01 42	MPCP Rx Register	R	
0x01 43	MPCP Rx Reg Req	R	
0x01 44	MPCP Rx Report	R	

I.2 DPoE Attributes (Branch 0xD7)

The table below lists attributes defined for managing extended features with DPoE OAM. See Section 9 for Branch D7 attribute details.

Table 166 - DPoE Attributes (Branch D7)⁶⁵

Leaf (HEX)	Attribute	Read/ Write	Description
D-ONU Management			
0x0002	Device ID	R	Lowest (numerically smallest) TU MAC address
0x0003	Firmware info	R	Firmware information
0x0004	Chipset Info	R	Type of chip used on the D-ONU
0x0005	Date of Manufacture	R	Date of Manufacture
0x0006	Manufacturer Info	R	Manufacturer-specific information
0x0007	Max Logical Links	R	Maximum LLIDs
0x0008	Number of Network Ports	R	Number of TU interface ports on the D-ONU
0x0009	Number of S1 interfaces	R	Number of S1 interfaces on D-ONU
0x000A	D-ONU Packet Buffer	R	Packet buffer capabilities
0x000B	Report Thresholds	R/W	threshold levels used to generate REPORT MPCPDUs
0x000C	Logical Link Forwarding State	R	Current traffic state for a logical link
0x000D	OAM Frame Rate	R	Maximum rate at which OAM PDUs are transmitted on a link
0x000E	ONU Manufacturer Organization Name	R	Organization name which manufactured the D-ONU
0x000F	Firmware Mfg Time Varying Controls	R	The firmware CVC and CVS validity times
0x0010	D-ONU Port Type	R	Type of individual ports and devices connected to them (if present)
0x0011	Vendor Name	R	ONU vendor name
0x0012	Model Number	R	ONU model number
0x0013	Hardware Version	R	ONU hardware version
0x0014	EPON Mode	R	EPON Mode capabilities
0x0015	Software Bundle	R	Software Bundle Description (augments SW_REV)
Bridging			
0x0101	Dynamic Learning Table Size	R	Maximum size of the D-ONU MAC address learning table
0x0102	Dynamic Address Age Limit	R/W	Dynamic MAC learning table age limit
0x0103	Dynamic MAC Table	R	Dynamically learned MAC address rules of one Ethernet port
0x0104	Static MAC Table	R	Statically provisioned MAC address table
0x0105	S1 Interface Port Auto-negotiation	R	Auto-negotiation advertisement values used by a port
0x0106	Source Address Admission Control	R/W	MAC Source Address-based admission function operating on the selected upstream DPOE ONU port
0x0107	MAC Learning Min Guarantee	R/W	Minimum number of MAC addresses that can be learned on an individual UNI port
0x0108	MAC Learning Max Allowed	R/W	Maximum allowed number of MAC addresses on an individual S1 port
0x0109	MAC Learning Aggregate Limit	R/W	Aggregate dynamic MAC address limit for the D-ONU as a whole
0x010A	Len Error Discard	R/W	Length Error Discard Enable status of the D-ONU ports
0x010B	Flood Unknown	R/W	Flooding control of downstream frames whose destination addresses have not been learned
0x010C	Local Switching	R/W	configuration of a port for local switching
0x010D	LLID and Queue Configuration	R/W	configures the number of LLIDs to be registered by the given D-ONU

⁶⁵ Revised per OAMv2.0-N-15.0229-1 on 2/11/16 by JB. Revised per OAMv2.0-N-16.0247-3 on 11/1/2016 by JB..

Leaf (HEX)	Attribute	Read/ Write	Description
0x010E	Firmware Filename	R	Name of the DPoE ONU firmware file
0x010F	MAC Table Full Behavior	R/W	Controls behavior of the D-ONU MAC address learning process
Statistics And Counters			
0x0201	Rx Frames Green	R/W	Count of frames received at one port
0x0202	Tx Frames Green	R/W	Count of frames transmitted from one port
0x0203	Rx Frame Too Short	R/W	RxFrameTooShort counter of one port
0x0204	Rx Frame 64	R/W	RxFrame64 counter of one port
0x0205	Rx Frame 65_127	R/W	RxFrame65_127 counter of one port
0x0206	RxFrame128_255	R/W	RxFrame128_255 counter of one port
0x0207	Rx Frame 256_511	R/W	RxFrame256_511 counter of one port
0x0208	Rx Frame 512_1023	R/W	RxFrame512_1023 counter of one port
0x0209	Rx Frame 1024_1518	R/W	RxFrame1024_1518 counter of one port
0x020A	Rx Frame 1519 Plus	R/W	RxFrame1519Plus counter of one port
0x020B	Tx Frame 64	R/W	TxFrame64 counter of one port
0x020C	Tx Frame 65_127	R/W	TxFrame65_127 counter of one port
0x020D	Tx Frame 128_255	R/W	TxFrame128_255 counter of one port
0x020E	Tx Frame 256_511	R/W	TxFrame256_511 counter of one port
0X020F	Tx Frame 512_1023	R/W	TxFrame512_1023 counter of one port
0X0210	Tx Frame 1024_1518	R/W	TxFrame1024_1518 counter of one port
0X0211	Tx Frame 1519 Plus	R/W	TxFrame1519Plus counter of one port
0X0212	Queue Delay Threshold	R/W	Threshold for Delay that causes Bytes Delayed counter to increment for a queue
0X0213	Queue Delay	R/W	Maximum Frame Delay experienced since statistic reset for a queue
0X0214	Frames Dropped	R/W	Frames dropped due to queue overflow or rate control discard
0X0215	Bytes Dropped	R/W	Bytes dropped due to queue overflow or rate control discard
0X0216	Bytes Delayed	R/W	Bytes in frames with a D-ONU queue residency time greater than DelayThreshold for a queue
0X0217	Tx Bytes Unused	R/W	Bytes granted to the Unicast Logical Link but not filled with transmitted data
0X021D	Optical Mon Temperature	R/W	Optical module temperature
0X021E	Optical Mon Vcc	R/W	Optical module Vcc
0X021F	Optical Mon Tx Bias Current	R/W	Current optical module Tx bias current
0X0220	Optical Mon Tx Power	R/W	Current optical module Tx power
0X0221	Optical Mon Rx Power	R/W	Current optical module Rx power
0X0222	Rx Frames Yellow	R/W	Frames received at one port
0X0223	Tx Frames Yellow	R/W	Frames transmitted from one port
0X0224	Tx Bytes Green	R/W	Bytes in green frames transmitted from one port
0X0225	Rx Bytes Yellow	R/W	Bytes in yellow frames received at one port
0X0226	Rx Bytes Green	R/W	Bytes in green frames received at one port
0X0227	Tx Bytes Yellow	R/W	Bytes in yellow frames transmitted from one port
0X0228	Tx Frames Unicast	R/W	Frames transmitted with a unicast L2 DA
0X0229	Tx Frames Multicast	R/W	Frames transmitted with a multicast L2 DA
0X022A	Tx Frames Broadcast	R/W	Frames transmitted with the broadcast L2 DA
0X022B	Rx Frames Unicast	R/W	Frames received with a L2 unicast DA
0X022C	Rx Frames Multicast	R/W	Frames received with a multicast L2 DA
0X022D	Rx Frames Broadcast	R/W	Frames received with the broadcast L2 DA

Leaf (HEX)	Attribute	Read/ Write	Description
0X022E	Number of Programmable Counters	R	Programmable frame/byte counters supported
0X022F	L2CP Frames Rx	R/W	Layer 2 control protocol frames received
0X0230	L2CP Octets Rx	R/W	Layer 2 control protocol frames received
0X0231	L2CP Frames Tx	R/W	Layer 2 control protocol frames transmitted
0X0232	L2CP Octets Tx	R/W	Layer 2 control protocol frames transmitted
0X0233	L2CP Frames Discarded	R/W	Layer 2 control protocol frames discarded
0X0234	L2CP Octets Discarded	R/W	Layer 2 control protocol frames discarded
0X0235	Tx L2 Errors	R/W	Frames that failed to transmit because of an error in the data link layer
0X0236	Rx L2 Errors	R/W	Frames discarded due to errors in the frame
Alarms			
0X0301	Port Stat Threshold	R/W	Port statistics counter threshold
0X0302	Link Stat Threshold	R/W	Link statistics counter threshold
0X0303	Suspend/Resume Alarm Reporting	R/W	Enable or disable transmission alarms
Security			
0X0401	Encryption Key Expiry Time	R/W	Timeout value for encryption keys
0X0402	Encryption Mode	R/W	Encryption method to be used on a particular logical link
Frame Processing			
0X0501	Port Ingress Rule	R/W	A rule in the ingress table of the current port
0X0502	Custom Field	R/W	
0X0503	C-VLAN TPID	R/W	Alternate EtherType value (C-VLAN)
0X0504	S-VLAN TPID	R/W	alternate EtherType (S-VLAN)
0X0505	IPMC Forwarding Rule Configuration	R/W	A unique IP multicast group
0X0506	I- TPID	R/W	Alternate I-TPID (I-Tag)
0X0507	B- TPID	R/W	Alternate B-TPID (B-Tag)
Service Level Agreements			
0X0601	Broadcast Rate Limit	R/W	Number of broadcast frames that can be received through the Ethernet interface
0X0602	Reserved		Deprecated in DPoE 2.0
0X0603	Reserved		Deprecated in DPoE 2.0
0X0604	Queue Committed Information Rate	R/W	CIR output rate from a queue
0X0605	FEC Mode	R/W	Current FEC mode
0X0606	Queue Excess Information Rate	R/W	EIR output rate from a queue
0X0607	Queue Color Marking	R/W	Frame marking method
0X0608	Queue Rate Limiter Capabilities	R	Rate limiting method
0X0609	Coupling Flag	R/W	MEF coupling flag for joint behavior of the CIR/EIR shapers
Clock Transport			
0X0701	Clock Transport Capabilities	R	Port capability to support 1 PPS+TOD or 1588v2 timing interfaces
0X0702	Enable Clock Transport	R/W	Enables the selected type of clock transport
0X0703	Time Transfer	R/W	Sets the time for the next ToD synchronization event
0X0704	Propagation Parameters	R/W	Refractive index of the fiber
0X0705	RTT	R/W	Round-trip time (RTT) measured by the DPoE System
Reserved			

Leaf (HEX)	Attribute	Read/ Write	Description
0X0800	Reserved		Deprecated in DPoE 2.0
0X0801	Reserved		Deprecated in DPoE 2.0
0X0802	Reserved		Deprecated in DPoE 2.0
0X0803	Reserved		Deprecated in DPoE 2.0
UNI Management			
0X0820	Energy Efficient Ethernet (EEE) status	R/W	Energy Efficient Ethernet for UNI port
0X0821	Power over Ethernet (PoE) status	R/W	POE for UNI Port
0X0822	Media Type	R/W	Media used on a selectable-media port
Link Protection			
0X0900	ONU Protection Capability	R/W	See [1904.1A], subclause 14.4.3.9.1
0X0901	ONU Protection Configuration	R/W	See [1904.1A], subclause 14.4.3.9.2
0X0902	PON Interface Administrate	R/W	See [1904.1A], subclause 14.4.3.9.3
0X0902	Config HoldOver	R/W	See [1904.1A], subclause 14.4.3.9.4
Power Saving			
0xFFFF	Power Saving Capabilities	R	[1904.1A], subclause 14.4.3.8.1

I.3 [802.3] Clause 30 Actions (Branch 09) (Informative)

These actions are defined in [802.3] Clause 30, and are repeated here for ease of reference.

Table 167 - [802.3] Clause 30 Actions (Branch 09)

Leaf (HEX)	Attribute	Description
0x00 05	PHY Admin Control	Enable/disable PHY
0x00 0B	Auto Neg Renegotiate	Force renegotiation
0x00 0C	Auto Neg Admin Ctrl	Auto Neg enable/disable

I.4 DPoE Actions (Branch 0xD9)

An action is identified by a Variable Container. Action parameters, if any, are included in the data portion of the container in the Set Request OAM PDU. Actions with no parameters have a zero length Container (Width code 0x80).

Responses to an action in the Set Response OAM PDU similarly have a list of Containers. Typically the response is just the result code (0x80, No Error, or a failure code). A response could return a result in the data portion of the container.

See Sections 9.7.6 through 9.7.14 for DPoE OAM PDUs for Branch D9.

Appendix II Example PDUs (Informative)

This informative-only appendix shows examples of DPoE OAM PDUs to illustrate the format and usage of these messages.

II.1 Get and Get Response

This example shows the use of the Object ID in a complex Get message that requests attributes from several objects. The Get message received from the DPoE System is shown on the left, with the corresponding D-ONU response on the right. The frame begins with some attribute TLVs (branch 7, D7), both standard and DPoE, without an object context. These attributes by definition refer to the default object, which is the EPON port and logical link on which the message was received. The D-ONU responds to an Object ID simply by echoing the TLV back in the Get Response. For each Variable Descriptor in the Get message, the D-ONU creates a matching Variable Container. Note that there is one response indicating an error code. All errors designate a length of 0 bytes, so there is no data field. As in the [802.3] standard, a branch value of zero terminates the list of TLVs. This null terminator is always in the message; it is not padding.

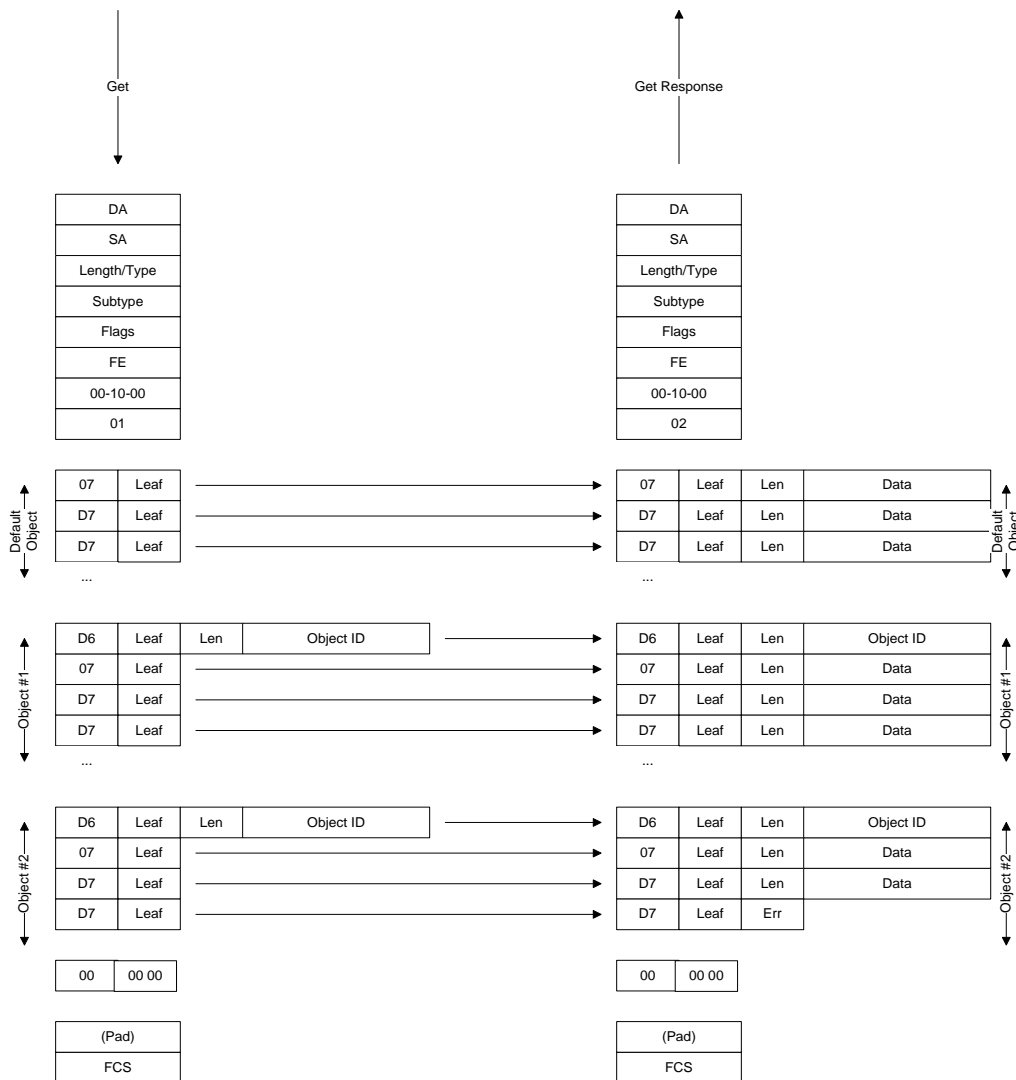

Figure 19 - Get and Get Response

II.2 Set and Set Response

This example shows a Set message, including a change in Object ID. Note that both standard and extended attributes can be set in a single message. Set messages have Variable Containers rather than Descriptors in the Get, because to set an attribute, you must specify both the attribute and its new value. The response to a Set is a TLV with a return code (usually RcOk, but perhaps an error) indicating zero data. Actions (branch codes 0x09, 0xD9) can also be included in a set message. Actions often have parameters (ex: Add MAC address (M1)), so they are also Variable Containers. For consistency in parsing, even actions with no parameters, such as D-ONU Reset, use the Variable Container format with a length of zero.

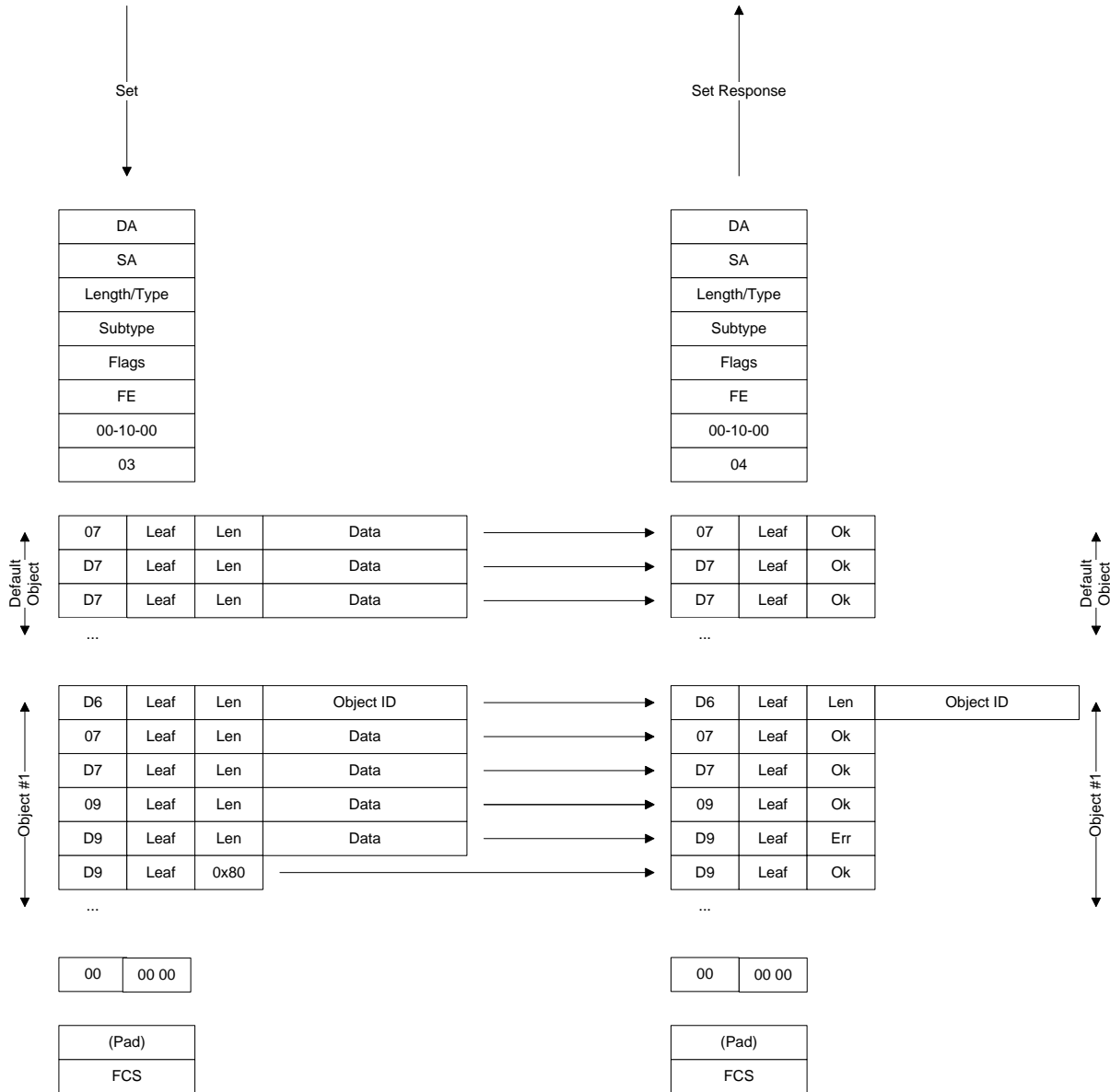

Figure 20 - Set and Set Response

II.3 Large Attribute Values

This example illustrates the format for a large return value, in this case the MAC address table for a particular UNI port. The Get Request PDU contains a single attribute, but the reply is larger than 128 bytes, and so requires several containers for the response.

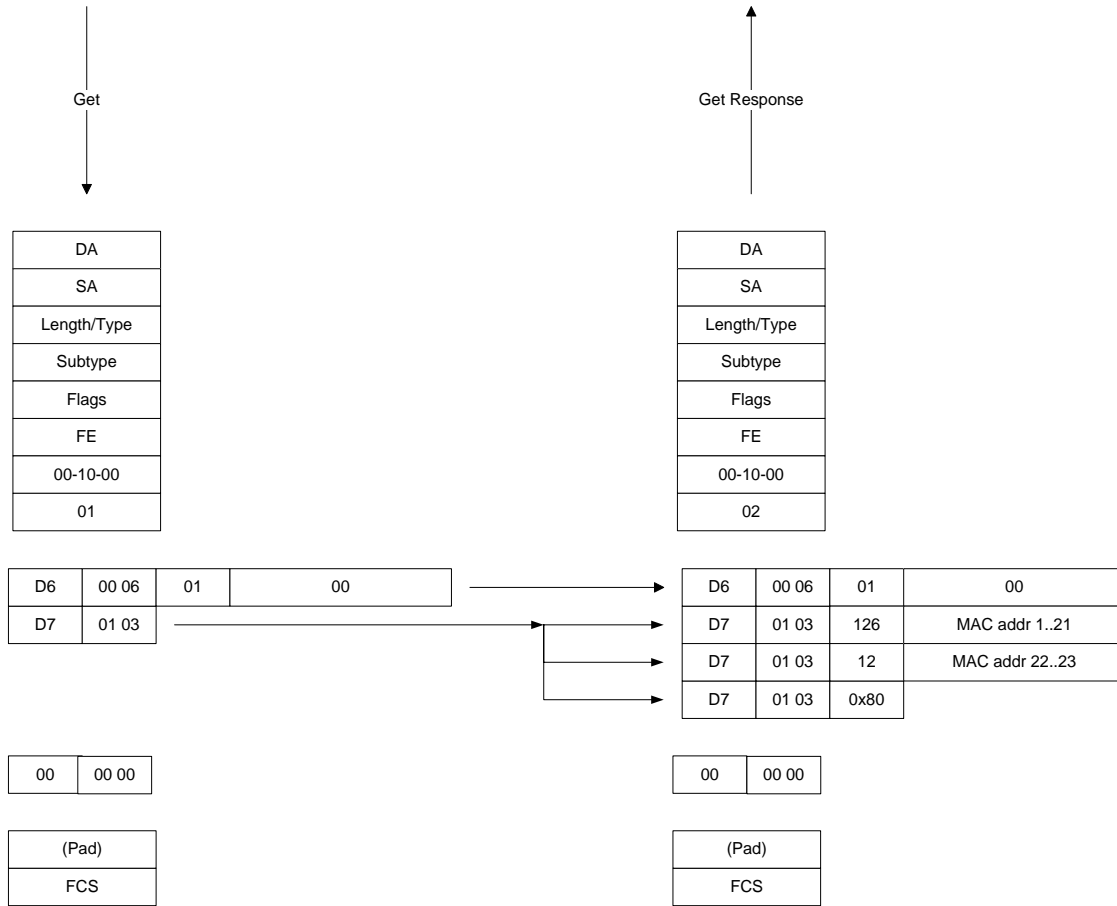

Figure 21 - Large Attribute Values

II.4 Multi-Part Replies

The following diagram illustrates the use of the sequence number attribute in a two-part reply to a single Get PDU. For the sake of example, the reply is assumed to be a single attribute, an extremely large MAC address table, as in the previous example. A multi-part reply also might be generated in response to a long list of small attributes.

Note that the large attribute is not terminated in the first frame as it is not yet complete, but is terminated only in the second frame.

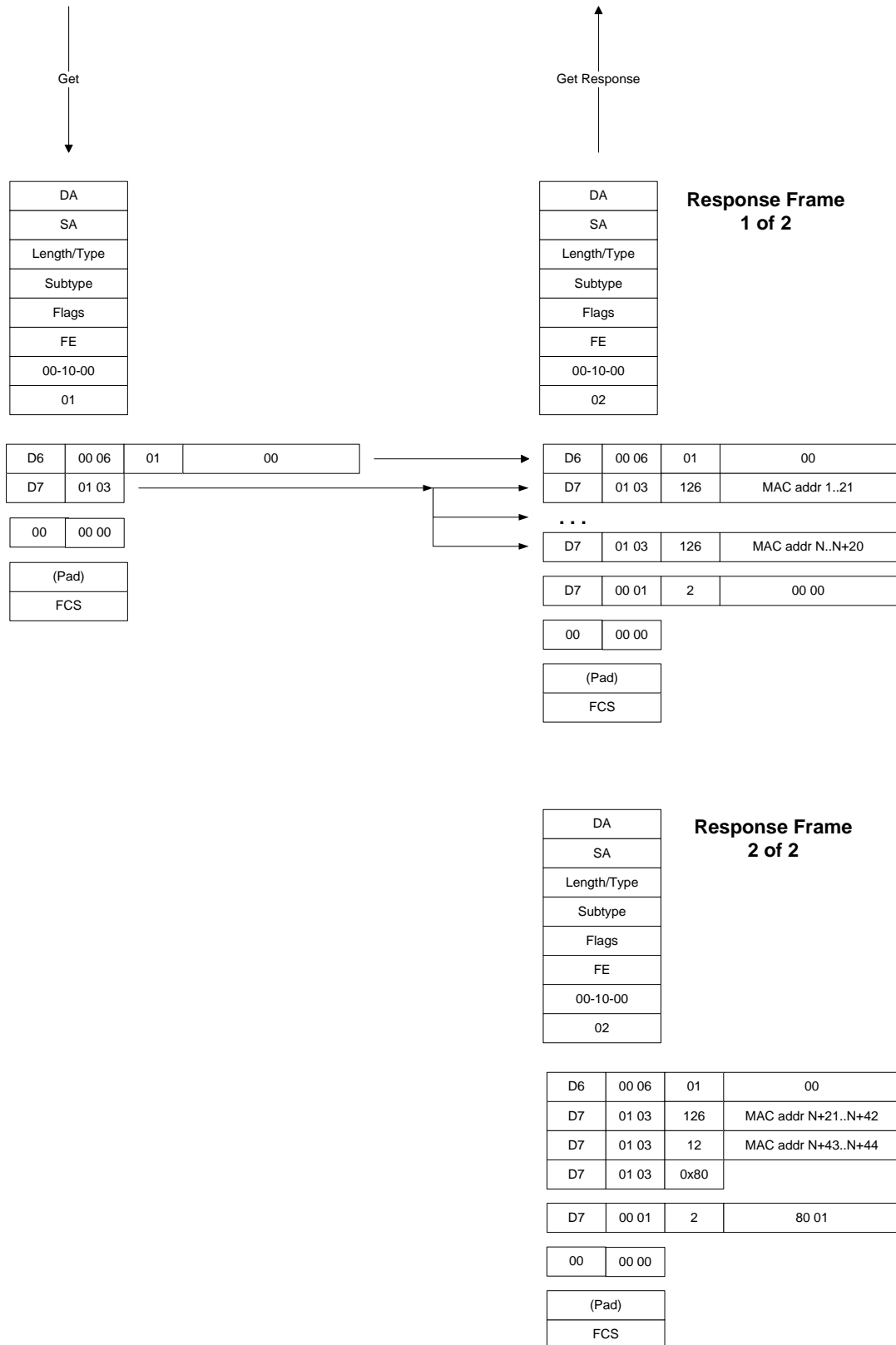

Figure 22 - Multi-Part Replies

II.5 Encryption and Key Exchange Messages⁶⁶

This PDU is used to set the key exchange interval on the D-ONU.

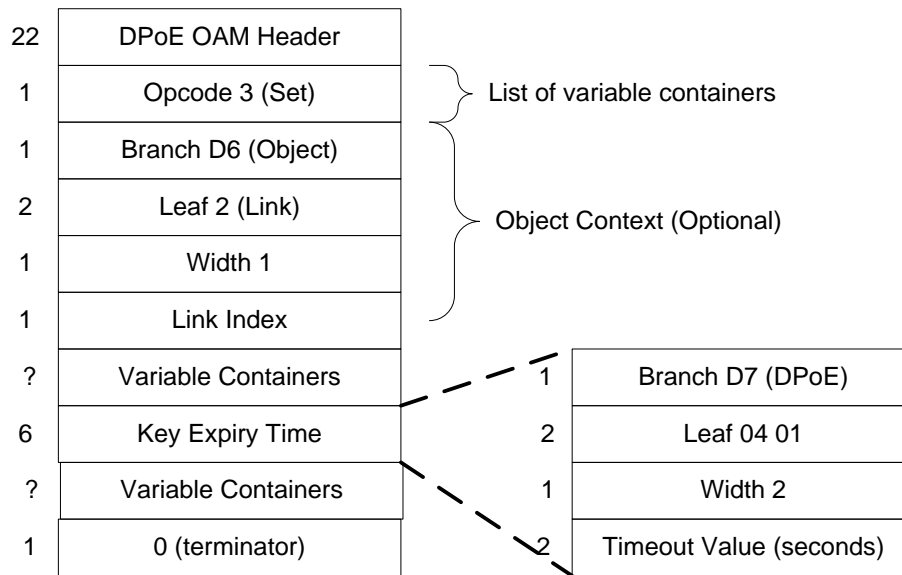

Figure 23 - Set Key Exchange Timer Request PDU

```

+ Ethernet Frame
DA.....01 80 c2 00 00 02
SA.....54 4b 37 21 00 00
EtherType.....88 09 (Slow Protocol)
SubType.....03 (OAM)
+ OAM PDU
  Flags.....00 10
  Code.....fe (Organization Specific)
  OUI.....00 10 00 (DPoE)
+ DPoE PDU
  OpCode.....03 (Set)
+ TLV
  Branch.....d6 (Object Context)
  Leaf.....00 02 (LLID)
  Width.....02
  Value.....00 00 (LLID Index 0)
+ TLV
  Branch.....d7 (DPoE attribute)
  Leaf.....04 01 (Encryption Key Expiry Time)
  Width.....02
  Value.....00 3c (60 seconds)
+ TLV
  Branch.....00 (Branch null (terminator))
  Leaf.....00 00 (Leaf null (terminator))
+ PAD
+ FCS

```

⁶⁶ Revised per OAMv2.0-N-13.0102-1 on 10/9/13 by JB.

II.5.1 Set Key Exchange Timer Response PDU

This PDU is returned to inform the DPoE System if the D-ONU was successfully configured (or not successfully configured) with the Key Exchange Timer value specified in a Set Request Message.

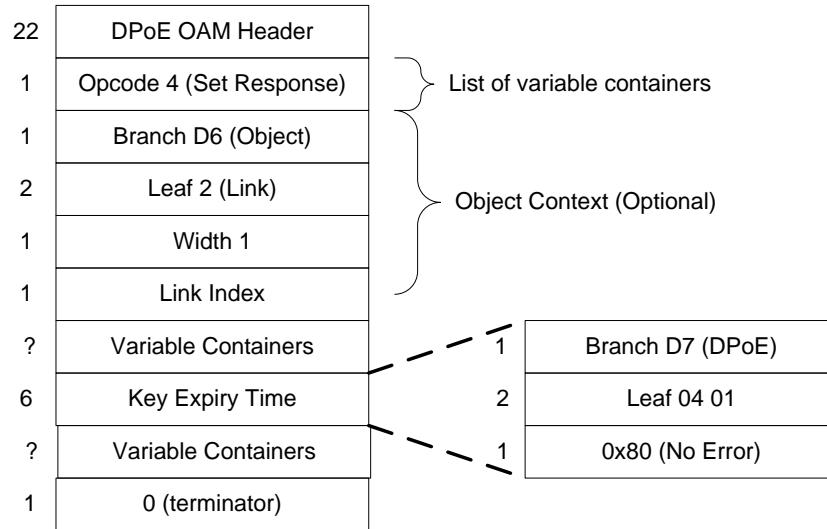

Figure 24 - Set Key Exchange Timer Response PDU

```

+ Ethernet Frame
DA.....01 80 c2 00 00 02
SA.....54 4b 37 01 00 ab
EtherType.....88 09
SubType.....03 (OAM)
+ OAM PDU
Flags.....00 50
Code.....fe (Organization Specific)
OUI.....00 10 00 (DPoE)
+ DPoE PDU
OpCode.....04(Set Response)
+ TLV
Branch.....d6 (Object)
Leaf.....00 02 (LLID)
Width.....02
Value.....00 00 (LLID Index)
+ TLV
Branch.....d7 (DPoE Attribute)
Leaf.....04 01 (Encryption Key Expiry Time)
Width/Code..80 (No Error)
+ TLV
Branch.....00 (Branch null (terminator))
Leaf.....00 00 (Leaf terminator)
+ PAD
+ FCS
    
```

II.5.2 Get Key Exchange Timer PDU

This PDU may be used by the DPoE System to query the D-ONU to determine the currently specified Key Exchange Timer value used by one of the D-ONU's links.

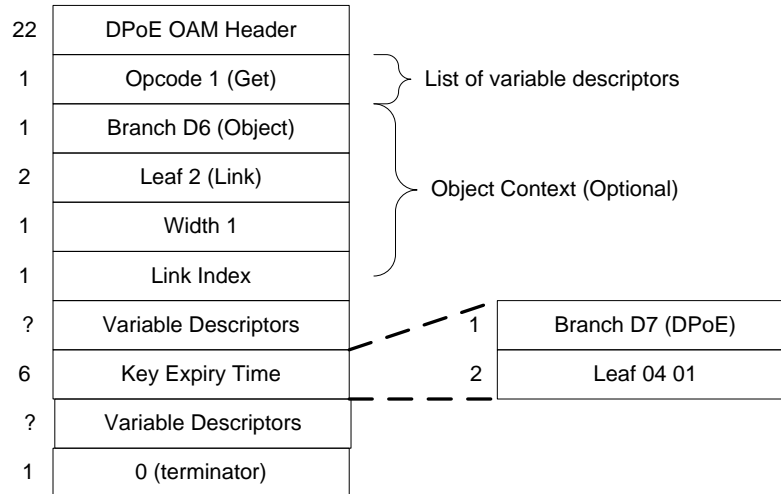

Figure 25 - Get Key Exchange Timer PDU

```

+ Ethernet Frame
DA.....01 80 c2 00 00 02
SA.....54 4b 37 21 00 00
EtherType.....88 09 (Slow Protocol)
SubType.....03 (OAM)
+ OAM PDU
Flags.....00 10
Code.....fe (Organization Specific)
OUI.....00 10 00 (DPoE)
+ DPoE PDU
OpCode.....01 (Get)
+ TLV
Branch.....d6 (Object Context)
Leaf.....00 02 (Link)
Width.....02
Value.....00 00 (LLID Index 0)
+ TLV
Branch.....d7 (DPoE Attribute)
Leaf.....04 01 (Key Exchange Expiry Time)
+ TLV
Branch.....00 (Branch null (terminator))
+ PAD
+ FCS
    
```

II.5.3 Get Key Exchange Timer Response PDU

All D-ONU implementations respond either with the provisioned Key Exchange Timer Value or an appropriate error Container Value if queried by the DPoE System.

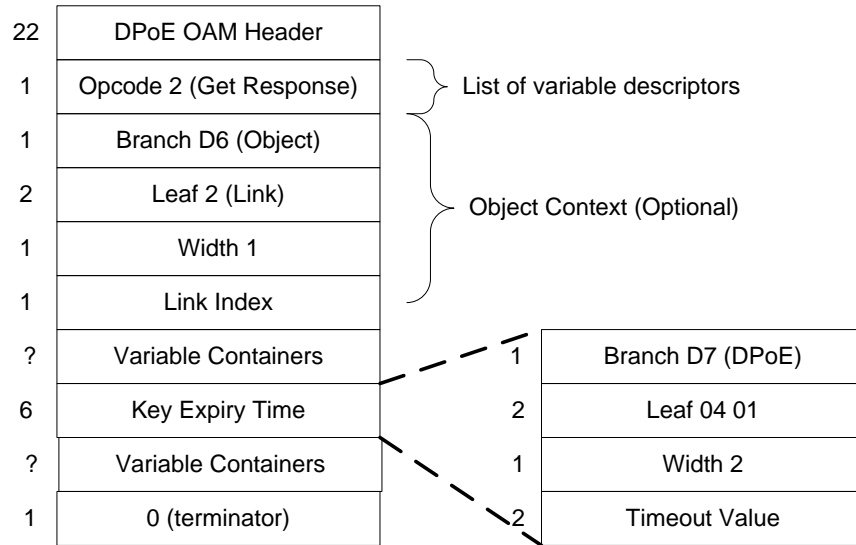

Figure 26 - Get Key Exchange Timer Response PDU

```

+ Ethernet Frame
DA.....01 80 c2 00 00 02
SA.....54 4b 37 01 00 ab
SubType.....88 09 (Slow Protocol)
Flags.....03 (OAM)
+ OAM PDU
  Flags.....00 50
  Code.....fe (Organization Specific)
  OUI.....00 10 00 (DPoE)
+ DPoE PDU
  OpCode.....02 (Get Response)
+ TLV
  Branch.....d6 (Object Context)
  Leaf.....00 02 (Link)
  Length.....02
  Value.....00 00 (LLID Index 0)
+ TLV
  Branch.....d7 (DPoE attribute)
  Leaf.....04 01 (Key Exchange Expiry Timer)
  Width.....02
  Value.....00 3c
+ TLV
  Branch.....00 (Branch null (terminator))
+ PAD
+ FCS
    
```

II.6 Key Exchange Message

This message is example showing the key value being the D-ONU to DPoE System.

```
+ Ethernet Frame
  DA.....01 80 c2 00 00 02
  SA.....54 4b 37 01 00 ab
  EtherType.....88 09 (Slow Protocol)
  SubType.....03 (OAM)
+ OAM PDU
  Flags.....00 50
  Code.....fe (Organization Specific)
  OUI.....00 10 00 (DPoE)
+ DPoE PDU
  OpCode.....08 (Key Exchange)
  KeyNumber.....00
  KeySize.....10
  Key.....04 b9 98 48 04 a2 72 41
           d1 a0 5a 36 67 db 85 66

+ PAD
+ FCS
```

II.7 Example 1Down Key Exchange Sequence⁶⁷

```
Set Key Exchange Timer (60 seconds)
-----
01 80 c2 00 00 02 54 4b 37 21 00 00 88 09 03 00
10 fe 00 10 00 03 d7 04 01 02 00 3c 00 00 00 ...

Set Key Exchange Timer Response
-----
01 80 c2 00 00 02 54 4b 37 01 00 ab 88 09 03 00
50 fe 00 10 00 04 d7 04 01 80 00 00 ...

Get Key Exchange Timer
-----
01 80 c2 00 00 02 54 4b 37 21 00 00 88 09 03 00
10 fe 00 10 00 01 d7 04 01 00 00 00 ...

Get Key Exchange Timer Response
-----
01 80 c2 00 00 02 54 4b 37 01 00 ab 88 09 03 00
50 fe 00 10 00 02 d7 04 01 02 00 3c 00 00 ...

Key Exchange Message
-----
01 80 c2 00 00 02 54 4b 37 01 00 ab 88 09 03 00
50 fe 00 00 10 00 01 10 ad b5 01 ab cc a8 12 68
eb 94 35 7d ec 08 3c 65 00 00 00 ...
```

⁶⁷ Revised per OAMv2.0-N-13.0102-1 on 10/9/13 by JB.

Key Exchange Message

```
-----
01 80 c2 00 00 02 54 4b 37 01 00 ab 88 09 03 00
50 fe 00 10 00 08 00 10 94 cb 49 59 38 d1 5b a3
d2 7d e6 ca fd 00 9f 1f 00 00 00 ...
```

Key Exchange Message

```
-----
01 80 c2 00 00 02 54 4b 37 01 00 ab 88 09 03 00
50 fe 00 10 00 08 01 10 80 52 4c cc 21 9d 08 ea
4e 18 f5 fb 24 48 79 d6 00 00 ...
```

II.8 LLID and Queue Configuration TLV

The following example shows the contents of a Link and Queue Configuration TLV that configures two links and two UNI ports as follows

- Upstream Configuration: N (number of links) = 2
- LLID 0 configuration: [M=2, (Queue 0 Size=10, Queue 1 size=10)]
- LLID 1 configuration: [M=1, (Queue 0 Size = 5)]
- Downstream Configuration: P (number of ports) = 2
- Port 0 (i.e., UNI port 1) configuration: [J=2, (Queue 0 Size=5, Queue 1 Size=5)]
- Port 1 (i.e., UNI port 2) configuration: [J=1, (Queue 0 Size=8)]

```
D7 01 0D 0C          ; branch/leaf for LLID/Queue Config TLV; length 12 bytes
02                  ; 2 LLIDs
    02              ; LLID 0 has 2 queues
        0A          ; LLID 0 queue 0 is size 40 KB
        0A          ; LLID 0 queue 1 is size 40 KB
    01              ; LLID 1 has 1 queue
        05          ; LLID 1 queue 0 is size 20 KB
02                  ; 2 User Ports
    02              ; Port 0 has 2 queues
        05          ; Port 0 queue 0 is size 20 KB
        05          ; Port 0 queue 1 is size 20 KB
    01              ; Port 1 has 1 queue
        08          ; Port 1 queue 0 is size 32 KB
```

Appendix III Life Cycle of a Unicast Logical Link (Informative)⁶⁸

The diagram below illustrates typical events in the OAM sequence for a unicast logical link. As a merely informative example, this diagram does not require a particular order of operation or set of messages. Any such requirements appear elsewhere in the DPoE specifications. Figure 27 is intended as an aid to overall comprehension only.

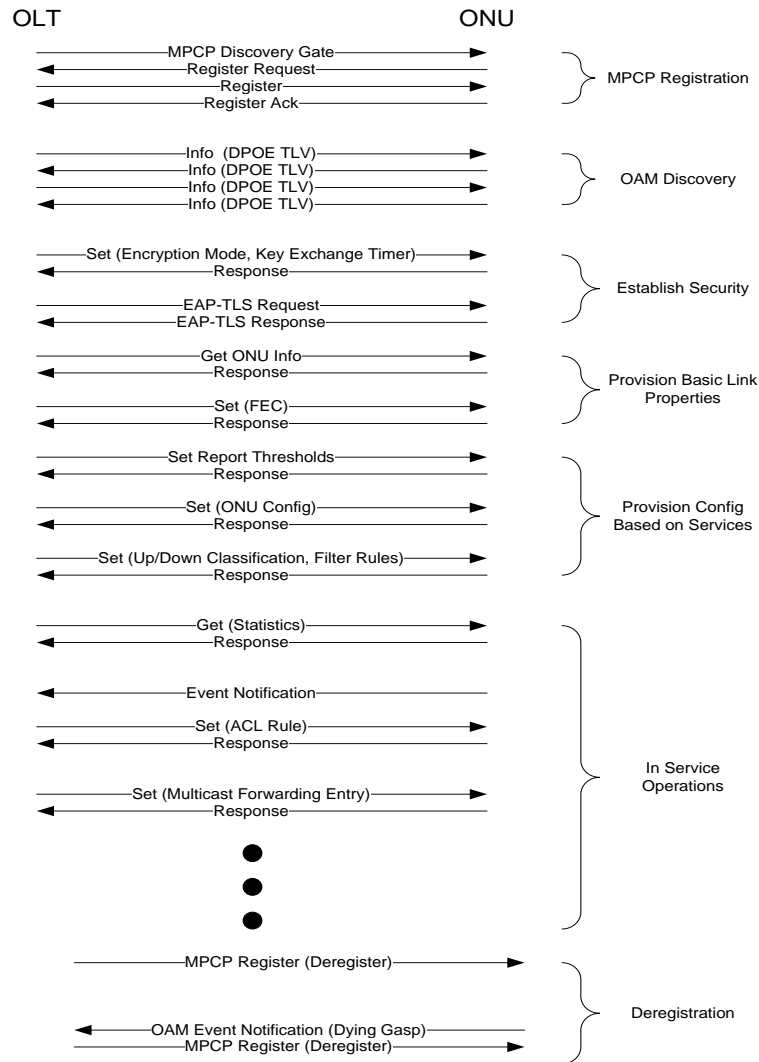

Figure 27 - Unicast Logical Link Life Cycle

III.1 MPCP Registration⁶⁹

Initial detection of a logical link occurs by MPCP registration as specified in [802.3] Clause 64 and Clause 77. Range to the D-ONU and MAC address of the logical link are first available at this point.

⁶⁸ Revised per OAMv2.0-N-14.0200-1 on 11/20/14 by JB.

⁶⁹ Revised per OAMv2.0-N.14.0173-1 and OAMv2.0-N.14.0192-1 on 7/18/14 by JB.

III.2 OAM Discovery

As per [802.3] Clause 57, OAM Discovery occurs immediately after registration. DPoE Networks all support OAM. Support for this extension is indicated by including a DPoE Info TLV in each Info PDU during discovery. As the active device, the DPoE System always transmits the first OAM PDU. The D-ONU begins transmitting its own Info PDUs once it receives a PDU from the DPoE System. (Note that the ONU PDU is not strictly a response to the DPoE System; these PDUs are sent based on a local timer, but that timer does not start until the first PDU arrives from the DPoE System.) The state machine in [802.3] Clause 57 requires two PDUs from each side to progress to the in-service state. It would be unusual for more than two PDUs to be required, as there is not a lot of negotiation to be carried out in this step.

III.3 Establish Discovery

It is desirable to establish encryption and authenticate the newly-discovered D-ONU as soon as possible, and before user data traffic is allowed to pass the D-ONU. These processes are carried out as defined by the DPoE specifications. Other OAM should be postponed until encryption has been established and the D-ONU has been authenticated.

III.4 Provision Basic Link Properties

The D-ONU Device ID and capabilities for the newly-discovered link would normally be queried early in the lifetime of a link. Any basic link properties necessary to operate the link might be provisioned first. For example, FEC for the link might be enabled.

III.5 Provision Configuration Based on Services

Once the identity of the D-ONU has been established and the link has been configured, the DPoE System can consult its database and configure the D-ONU as required to support the services authorized for this user. Commands might be sent to the D-ONU to establish its basic configuration (number of logical links, queues, and classification scheme); MPCP report thresholds would be established as appropriate for the SLA for the logical link; filter rules for the link might be established.

The first link registered from a physical D-ONU is likely to see more activity than others, as the DPoE System would provision configuration global to the entire D-ONU on this link, but not repeat that provisioning for later links.

III.6 In Service Operations

Periodic activity can be expected on a logical link once it is in service and basic provisioning has been established. For example, statistics might be regularly polled on the D-ONU by periodically sending a Get PDU requesting statistics attributes of various objects of interest. Some alteration in the provisioning of the D-ONU may occur based on events that occur after the D-ONU has registered. For example, DHCP snooping might learn an IP address assigned to a user device; in response, the DPoE System provisions an anti-spoofing ACL rule on the D-ONU to match that particular MAC/IP combination. Systems with remote-controlled multicast forwarding (as opposed to local D-ONU forwarding based on IGMP or MLD snooping) might send commands to add and remove multicast forwarding entries to the D-ONU as required. The D-ONU might autonomously report events to the DPoE System, particularly indications of faults.

III.7 Link Deregistration

The logical link will typically disappear when it is deregistered by management command, for example when a user unsubscribed from a service and that logical link is no longer needed, or if the D-ONU is powered off.

Appendix IV Example Rules (Informative)

This section shows some example rule sets to accomplish particular actions on a frame.

IV.1 Field Masking Example

Some field codes have sub-fields that are of interest. For example, an S-Tag has TPID, PCP, DEI, and VID fields. Rather than assign every sub-field a unique code for identification, the OAM message allows a number of bits on both the most significant ("left") side of the field and the least significant ("right") side to be ignored for purposes of comparison. The requirements for sub-field identification in an OAM message are described in Section 9.6.1.3. For the sake of notation in the following example and figures, a sub-field identifier will be written with the format {Field Code, Instance, MSB, LSB}.

As an example, to specify the TPID sub-field of an S-Tag in a PB frame, the sub-field identifier is {0x07,0,0,16}:

0x07 (identifies an S-VLAN field, per Table 91)

0 refers to the instance of the S-Tag in the frame

0 refers to the MSB mask (ignore no bits on the left side)

16 refers to and the LSB mask (ignore all bits of the VID, DEI, and PCP fields).

Similarly, to select just the PCP field of an S-Tag in a PB frame, the sub-field identifier is {0x07,0,16,13}:

0x07 (identifies an S-VLAN field, per Table 91)

0 refers to the instance of the S-Tag in the frame

16 refers to the MSB mask (ignore the 16 MSB -- the TPID)

13 refers to the LSB mask (ignore the VID and DEI).

The following figures depict the sub-field identifiers for OAM messages using the format described above.

Figure 28 depicts the sub-field identifiers used for an untagged Ethernet frame.

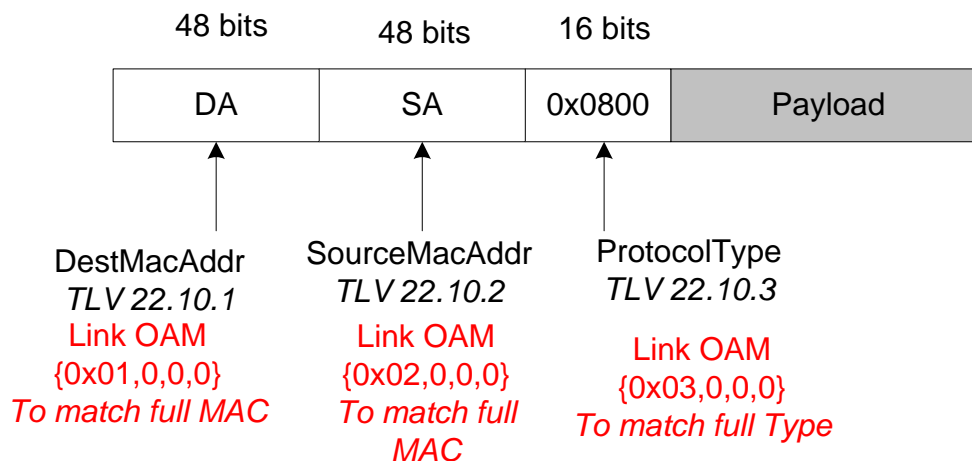

Figure 28 - Field Masking Example for Untagged Frame

Figure 29 depicts the sub-field identifiers used for an 802.1Q C-tagged frame. Note that the DA, SA and Protocol Type fields are able to be identified within the 802.1Q C-tagged frame, in addition to the fields in the tag.

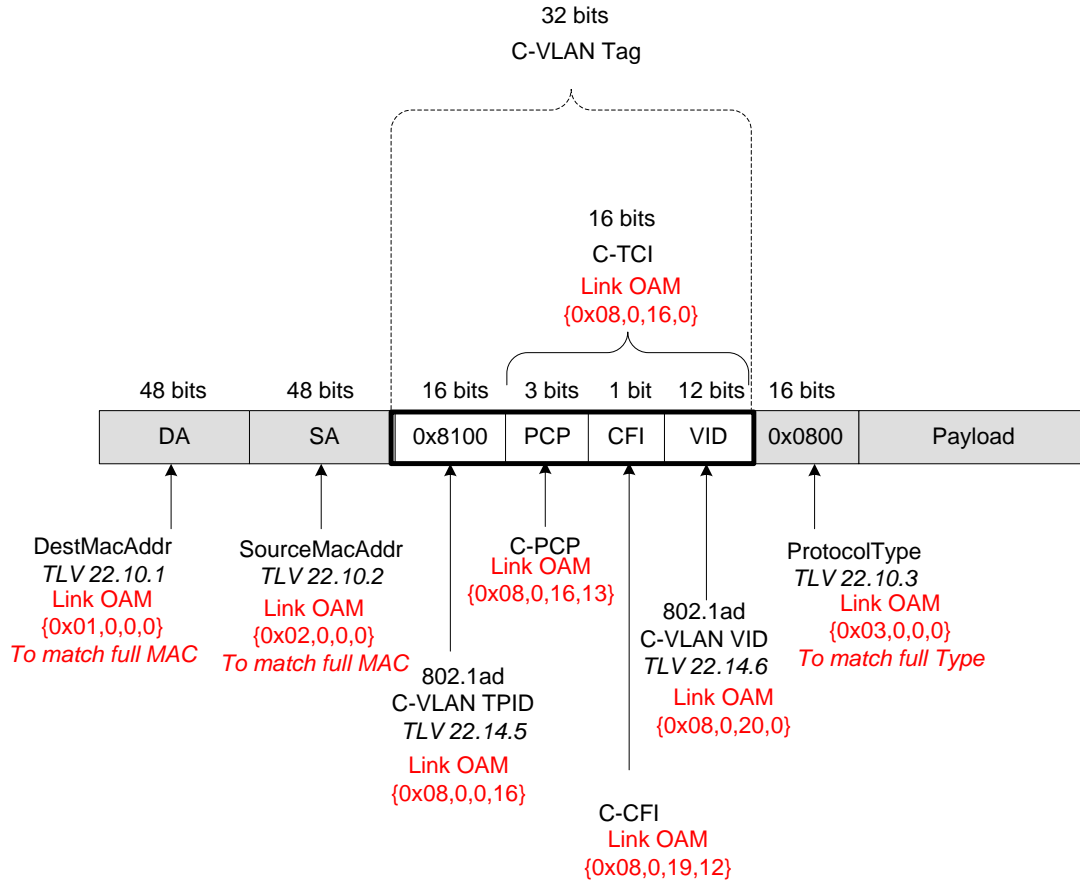

Figure 29 - Field Masking Example for 802.1Q C-tagged Frame

Figure 30 depicts the sub-field identifiers used for an 802.1ad tagged frame. Note that the original customer DA, SA and Protocol Type fields are able to be identified within the 802.1ad tagged frame, in addition to the S-Tag and C-Tag fields.

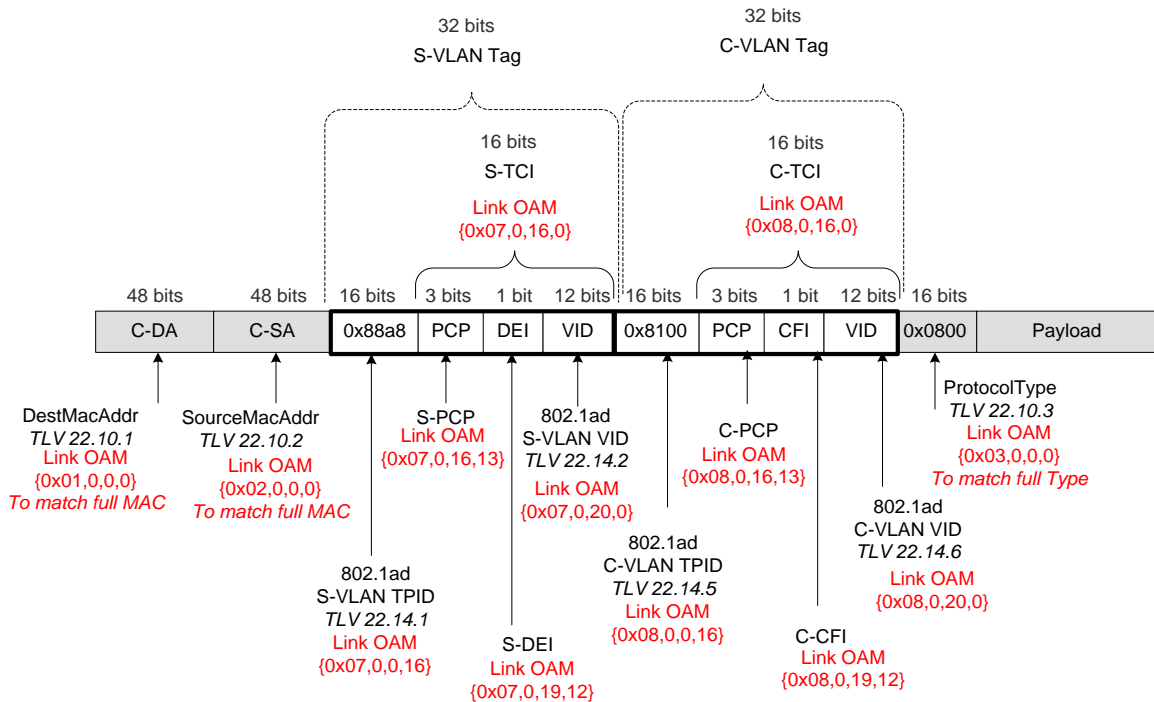

Figure 30 - Field Masking Example for 802.1ad Tagged Frame

Figure 31 depicts an 802.1ah encapsulated 802.1ad tagged frame. Note that the Customer DA, Customer SA and Protocol Type fields are able to be identified, in addition to the B-Tag, I-Tag, S-Tag and C-Tag fields. This example illustrates that to the D-ONU, a B-Tag is effectively an S-Tag, which is followed by an I-Tag, since both the B-Tag and S-Tag fields use 0x88a8 as the TPID. Therefore, to identify the B-Tag, the OAM message uses the sub-field identifier for the first instance of the S-Tag (i.e., 0). Likewise, to identify the S-Tag of the encapsulated 802.1ad frame the OAM message uses a sub-field identifier for the second instance of the S-Tag (i.e., 1).

As shown in Figure 31, the I-Tag field is considered to be 48 bits in length and does not include the Customer Destination MAC address or Customer Source MAC address. This deviates from IEEE 802.1ah, and applies to all DPoE requirements.

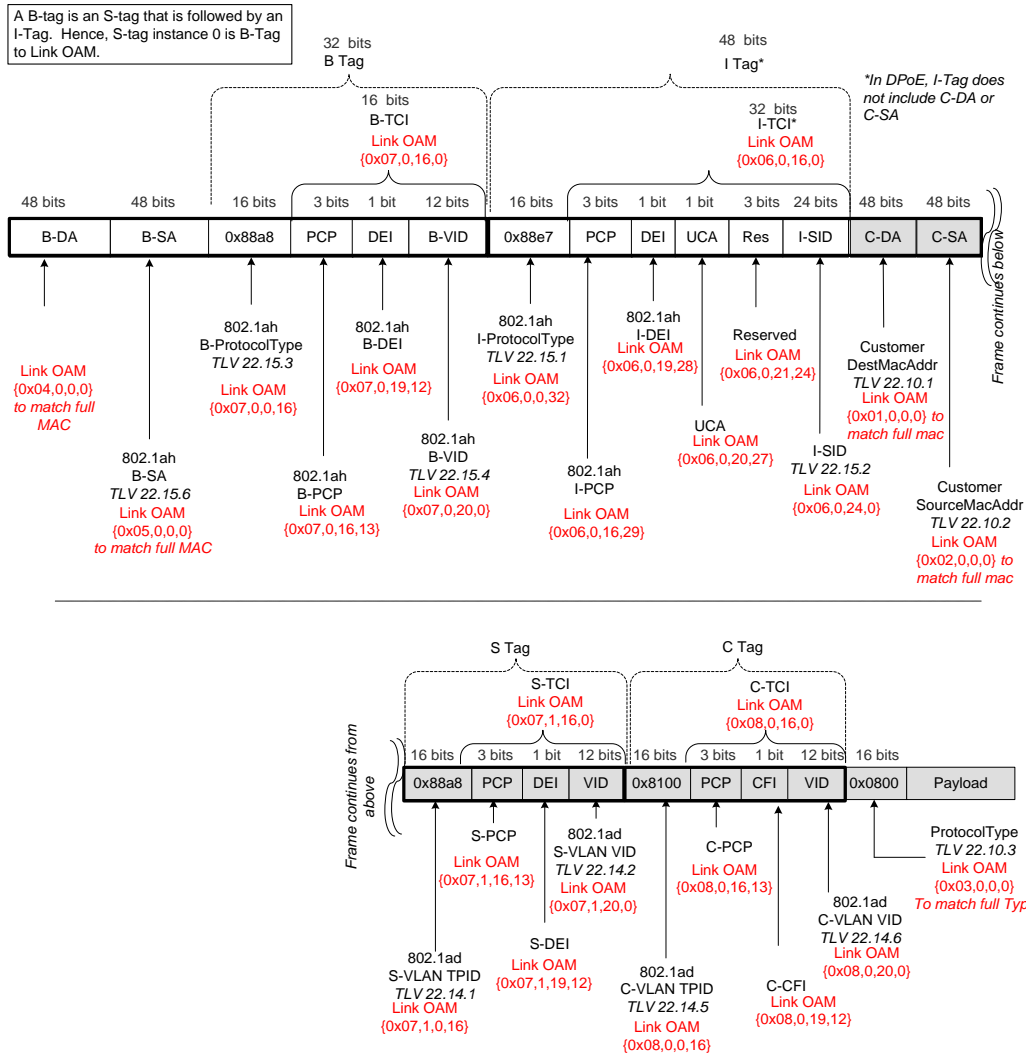

Figure 31 - Field Masking Example for 802.1ah Encapsulated 802.1ad Tagged Frame

IV.2 TPID Translation

Some legacy equipment uses pre-standard TPID values to indicate S-VLAN tags. For example, two tags in a frame might have TPIDs 0x9100 and 0x8100, rather than 0x88A8 and 0x8100. It can be desirable to normalize the TPID values so that core equipment only need be concerned with standard VLAN tag values.

Translating a value is a matter of matching frames to which we want to apply this translation, and then rewriting the appropriate value in the frame. Let's assume that the D-ONU has been instructed to treat TPID 0x9100 as a C-VLAN tag. The TPID of a VLAN tag can be found in the most significant 16 bits of the tag.

For these frames, we want to overwrite the VLAN tag with another VLAN tag with identical VID, but with a different TPID. One way to do this is to copy the input field to the output, and then overwrite the TPID.

Condition: ($\{C\text{-VLAN } 0, 0, 16\} == 0x9100$)

Result: Copy C-VLAN 0; Set (C-VLAN 0, 0, 16) 0x88A8; Replace C-VLAN 0;

Appendix V Acknowledgements

On behalf of our industry, we would like to thank the following individuals for their contributions to the development of this specification, listed in alphabetical order of company affiliation.

Contributor	Company Affiliation
John Dickinson, Edwin Mallette	Bright House Networks
Paul Gray, Drew Davis, Victor Hou	Broadcom
Curtis Knittle, Vikas Sarawat, Karthik Sundaresan, Lane Johnson, Glenn Russell	CableLabs
Jimmy Hu	Ciena
Tim Brophy	Cisco
Mehmet Toy, Shamim Akhtar	Comcast
Mike Holmes, Wen Li	Finisar Corporation
Hesham ElBakourey	Hitachi
Victor Blake	Independent Consultant
Janet Bean	Motorola
Dylan Ko	Qualcomm-Atheros
Michael Peters, Christopher Griffith	Sumitomo
Robert Harris, Armin Sepehri	Time Warner Cable
Marek Hajduczenia	ZTE

Steve Burroughs CableLabs

Appendix VI Revision History

VI.1 Engineering Changes for DPoE-SP-OAMv2.0-I02-130328

ECN	Date	Summary	Author
OAMv2.0-N-12.0048-1	10/08/2012	eOAMv2.0 for HW_REV, VENDOR, and MODEL	Curtis Knittle
OAMv2.0-N-12.0050-1	10/18/2012	Fixes to incorrect definition of attributes and TLV formats in OAMv2 I01	Marek Hajduczenia
OAMv2.0-N-12.0052-1	10/31/2012	Removal of optional requirement for 10G-EPON FEC	Marek Hajduczenia
OAMv2.0-N-12.0056-1	12/6/2012	Changes to OAM resulting from comments submitted by IEEE P1904.1	Marek Hajduczenia
OAMv2.0-N-12.0059-2	12/07/2012	Suspend/Resume Alarm changes (align with SIEPON)	Marek Hajduczenia
OAMv2.0-N-13.0062-1	12/15/2012	Changes to MPLS definition in DPoE OAM specs	Marek Hajduczenia
OAMv2.0-N-13.0066-2	1/24/2013	Delay and Drop Counters Simplification for OAMv2.0	Curtis Knittle

VI.2 Engineering Changes for DPoE-SP-OAMv2.0-I03-130808

ECN	Date	Summary	Author
OAMv2.0-N-13.0074-1	04/11/2013	Fixes to object context designation for some of clock transport TLVs	Marek Hajduczenia
OAMv2.0-N-13.0077-1	05/09/2013	Restore dropped eOAM Requirements	Steve Burroughs

VI.3 Engineering Change for DPoE-SP-OAMv2.0-I04-131114

ECN	Date	Summary	Author
OAMv2.0-N-13.0102-1	09/05/2013	Encryption Key Expiry Time Value for 2.0	Brionna Lopez

VI.4 Engineering Change for DPoE-SP-OAMv2.0-I05-140327

ECN	Date	Summary	Author
OAMv2.0-O-14.0122-1	02/27/2014	UNI management parameters in CM configuration file	Marek Hajduczenia

VI.5 Engineering Changes for DPoE-SP-OAMv2.0-I06-140807

ECN	Date	Summary	Author
OAMv2.0-N-14.0143-1	4/11/2014	IP(HSD) changes for DPoE2.0 OAM	Steve Burroughs
OAMv2.0-N-14.0154-1	5/22/2014	Updated Multicast Registration flags DPoE OAM v20	Curtis Knittle
OAMv2.0-N-14.0173-1	7/3/2014	Alignment and cleanup of 802.3 references	Marek Hajduczenia
OAMv2.0-N-14.0188-1	7/10/2014	DPoEv2 OAM edits to Support 2G-EPON	Lane Johnson
OAMv2.0-N-14.0192-1	7/10/2014	Multicast Logical Link Object Plus Others	Glen Kramer

VI.6 Engineering Changes for DPoE-SP-OAMv2.0-I07-150319

ECN	Date	Summary	Author
OAMv2.0-N-14.0199-1	10/30/2014	Support for Power Saving mechanism	Marek Hajduczenia
OAMv2.0-N-14.0200-1	11/20//2014	DPoG TLV Reservations, terminology alignment	Curtis Knittle
*OAMv2.0-N-14.0192-1	7/10/2014	<i>Corrected missing changes from previous ECN incorporation</i>	<i>Glen Kramer</i>

VI.7 Engineering Changes for DPoE-SP-OAMv2.0-I08-151210

ECN	Date	Summary	Author
OAMv2.0-N-15.0218-1	11/5/2015	Laser Power Off units corrected	Curtis Knittle
OAMv2.0-N-15.0221-2	11/5/2015	Multicast OAM Alignment P1904.1A	Steve Burroughs

VI.8 Engineering Changes for DPoE-SP-OAMv2.0-I09-160602

ECN	Date	Summary	Author
OAMv2.0-N-15.0224-1	12/10/2015	Support for Tree / Trunk optical line protection mechanism	Marek Hajduczenia
OAMv2.0-N-15.0229-1	12/31/2015	Remove DEMARC Specification References and Attributes	Steve Burroughs
OAMv2.0-N-15.0239-1	3/31/2016	DPoE 2.0 OAM - Retire SOAM Specification	Steve Burroughs

VI.9 Engineering Change for DPoE-SP-OAMv2.0-I10-170111

ECN	Date	Summary	Author
OAMv2.0-N-16.0247-3	10/20/2016	Add Software Bundle Object and clarify Manufacturer Info Version	Steve Burroughs

VI.10 Engineering Change for DPoE-SP-OAMv2.0-I11-170510

ECN	Date	Summary	Author
OAMv2.0-N-17.0248-3	04/13/2017	Add eSAFE Configuration Objects	Steve Burroughs
