

Data-Over-Cable Service Interface Specifications

DCA - MHA v2

Remote DOCSIS Timing Interface

CM-SP-R-DTI-I01-150615

ISSUED

Notice

This DOCSIS® specification is the result of a cooperative effort undertaken at the direction of Cable Television Laboratories, Inc. for the benefit of the cable industry and its customers. You may download, copy, distribute, and reference the documents herein only for the purpose of developing products or services in accordance with such documents, and educational use. Except as granted by CableLabs® in a separate written license agreement, no license is granted to modify the documents herein (except via the Engineering Change process), or to use, copy, modify or distribute the documents for any other purpose.

This document may contain references to other documents not owned or controlled by CableLabs. Use and understanding of this document may require access to such other documents. Designing, manufacturing, distributing, using, selling, or servicing products, or providing services, based on this document may require intellectual property licenses from third parties for technology referenced in this document. To the extent this document contains or refers to documents of third parties, you agree to abide by the terms of any licenses associated with such third-party documents, including open source licenses, if any.

© Cable Television Laboratories, Inc. 2014-2015

DISCLAIMER

This document is furnished on an "AS IS" basis and neither CableLabs nor its members provides any representation or warranty, express or implied, regarding the accuracy, completeness, noninfringement, or fitness for a particular purpose of this document, or any document referenced herein. Any use or reliance on the information or opinion in this document is at the risk of the user, and CableLabs and its members shall not be liable for any damage or injury incurred by any person arising out of the completeness, accuracy, or utility of any information or opinion contained in the document.

CableLabs reserves the right to revise this document for any reason including, but not limited to, changes in laws, regulations, or standards promulgated by various entities, technology advances, or changes in equipment design, manufacturing techniques, or operating procedures described, or referred to, herein.

This document is not to be construed to suggest that any company modify or change any of its products or procedures, nor does this document represent a commitment by CableLabs or any of its members to purchase any product whether or not it meets the characteristics described in the document. Unless granted in a separate written agreement from CableLabs, nothing contained herein shall be construed to confer any license or right to any intellectual property. This document is not to be construed as an endorsement of any product or company or as the adoption or promulgation of any guidelines, standards, or recommendations.

Document Status Sheet

Document Control Number:	CM-SP-R-DTI-I01-150615			
Document Title:	Remote DOCSIS Timing Interface			
Revision History:	I01 - Released 06/15/2015			
Date:	June 15, 2015			
Status:	Work in Progress	Draft	Issued	Closed
Distribution Restrictions:	Author Only	CL/Member	CL/Member/Vendor	Public

Key to Document Status Codes

Work in Progress	An incomplete document designed to guide discussion and generate feedback, and may include several alternative solutions for consideration.
Draft	A document in Specification format considered largely complete, but lacking review by Members and Technology Suppliers. Drafts are susceptible to substantial change during the review process.
Issued	A generally public document that has undergone Member and Technology Supplier review, cross-vendor interoperability, and is available for Certification testing. Issued Specifications are subject to the Engineering Change (EC) Process.
Closed	A static document, reviewed, tested, validated, and closed to further ECs.

Trademarks

CableLabs® is a registered trademark of Cable Television Laboratories, Inc. Other CableLabs marks are listed at <http://www.cablelabs.com/certqual/trademarks>. All other marks are the property of their respective owners.

Table of Contents

1	SCOPE	7
1.1	Introduction and Purpose.....	7
1.2	MHA v2 Interface Documents	7
1.3	Requirements and Conventions.....	8
2	REFERENCES	9
2.1	Normative References	9
2.2	Informative References	10
2.3	Reference Acquisition	10
3	TERMS AND DEFINITIONS	11
4	ABBREVIATIONS AND ACRONYMS	13
5	OVERVIEW	16
5.1	Introduction	16
5.2	DOCSIS.....	16
5.2.1	<i>System Requirements</i>	16
5.2.2	<i>Modular Implementation Requirements</i>	17
5.2.3	<i>System Description</i>	18
5.3	Precision Timing Synchronization Services.....	27
5.3.1	<i>Market Forces Drive Need for Precise Timing</i>	27
5.3.2	<i>DTP and R-DTI</i>	28
5.3.3	<i>Time Synchronization at NSI of RPD</i>	28
5.4	MPEG-TS Video	31
5.5	Video OOB Channel	31
5.5.1	<i>OOB 55-1</i>	31
5.5.2	<i>OOB 55-2</i>	31
5.5.3	<i>NDF and NDR</i>	31
6	SYSTEM REQUIREMENTS	33
6.1	DOCSIS Timing Requirements.....	33
6.1.1	<i>RPD Master Clock Frequency Accuracy for DOCSIS</i>	33
6.1.2	<i>RPD Master Clock Jitter</i>	33
6.1.3	<i>RPD Clock Generation for DOCSIS 3.1</i>	34
6.2	MPEG-TS Video.....	34
6.3	Video OOB.....	34
6.3.1	<i>OOB 55-1</i>	34
6.3.2	<i>OOB 55-2</i>	34
7	R-DTI IMPLEMENTATION SPECIFIC REQUIREMENTS	35
7.1	Protocol Support.....	35
7.2	DOCSIS Timing Requirements.....	35
7.3	Precision Timing Services.....	36
7.3.1	<i>Frequency Synchronization</i>	36
7.3.2	<i>Phase/Time Synchronization</i>	36
7.4	NDF and NDR.....	36
	APPENDIX I RPD AND DOCSIS SYSTEM PERFORMANCE	38
I.1	Introduction	38
I.2	Round-Trip Time and Performance.....	38
I.3	Elements of Round-Trip Time.....	38
	APPENDIX II ACKNOWLEDGEMENTS	40

List of Figures

Figure 1 - MHA v2 Reference Architecture for Remote PHY	16
Figure 2 - PTP Basic Synchronization Message Exchange	20
Figure 3 - PTP Timestamp, DOCSIS 3.0 Timestamp and DOCSIS 3.1 Extended Timestamp	22
Figure 4 - R-DTI Node_Slave Architecture – RPD Slave / Core Master	22
Figure 5 – R-DTI Node_Slave Architecture – RPD Slave / Core Slave / Common Master	23
Figure 6 - Basic Synchronization Message Exchange in Node_Slave Mode	23
Figure 7 - R-DTI Node_Master Architecture – RPD as the Timing Master	24
Figure 8 - Basic Synchronization Message Exchange in Node_Master Mode	25
Figure 9 - Operation Modes Co-existing in a Single CMTS System.....	26
Figure 10 - Deployment Example with Multiple CMTS Cores.....	27
Figure 11 - Network Deployment Example 1.....	29
Figure 12 - Network Deployment Example 2.....	30
Figure 13 - Network Deployment Example 3.....	30
Figure 14 - Network Deployment Example 4.....	31

List of Tables

Table 1 - RPD 10.24 MHz Master Clock Double Sideband Phase Noise Requirements	33
Table 2 - R-DTI Frequency Synchronization Performance	36
Table 3 - R-DTI Phase Synchronization Performance.....	36
Table 4 - Sample Values for the Round-Trip Time Components	39

This page intentionally left blank.

1 SCOPE

1.1 Introduction and Purpose

This specification is part of a series of specifications that defines modular headend architecture version 2 (MHA_{v2}). Specifically, it outlines a timing protocol between a cable converged access platform core function (CCAP-Core) and a series of remote physical Layer devices (Remote PHY Device or RPD) that enables the RPD to support DOCSIS/video/out-of-band (OOB) services.

The DOCSIS specification originally envisioned the cable modem termination system core function (CMTS Core), edge-QAM (EQAM) modulators, and upstream receiver functions on one assembly, fed with a common clock. The MHA architecture has its three components—the CMTS Core, the upstream receiver, and the EQAM modulators—located in separate chassis, and potentially in different physical locations. The DOCSIS timing interface (DTI) supports the accurate transport of the DTI server 10.24 MHz master clock, 32-bit DOCSIS timestamp, and time of day (ToD), to the DTI client within the MHA architecture. In doing so, it achieves timing synchronization across the cable network.

The MHA_{v2} architecture offers a different structure. The downstream (DS) RF modulation and upstream (US) RF demodulation functions are moved from the headend to the node together. Thus, the CCAP-Core and the RPD (two entities) are located in separate chassis, and potentially in different physical locations. The DS PHY and US PHY are located on one assembly – the Remote PHY Device, fed with a common clock. By moving signal conversion to the cable node, the MHA_{v2} architecture may improve RF performance, save space, decrease power consumption in the headend, and reduce operating cost. However, because of the variations in deployment scenarios and locations of the remote PHY nodes, it is not economically feasible to deliver the DTI source to every RPD. Frequency and phase offsets between the CCAP-Core and the RPD bring new challenges to the DOCSIS/video/OOB operations. The R-DTI specified in this document is intended to solve these issues.

1.2 MHA_{v2} Interface Documents

A list of the documents in the MHA_{v2} family of specifications is provided below. For updates, refer to <http://www.cablelabs.com/specs/specification-search/>.

Designation	Title
CM-SP-R-PHY	Remote PHY Specification
CM-SP-R-DEPI	Remote Downstream External PHY Interface Specification
CM-SP-R-UEPI	Remote Upstream External PHY Interface Specification
CM-SP-GCP	Generic Control Plane Specification
CM-SP-R-DTI	Remote DOCSIS Timing Interface Specification
CM-SP-R-OOB	Remote Out-of-Band Specification
CM-SP-R-OSSI	Remote PHY OSS Interface Specification

NOTE: MHA_{v2} does not explicitly use the original DTI specification or any of the original Modular Headend Architecture specifications.

1.3 Requirements and Conventions

Throughout this document, the words that are used to define the significance of particular requirements are capitalized. These words are:

"MUST"	This word means that the item is an absolute requirement of this specification.
"MUST NOT"	This phrase means that the item is an absolute prohibition of this specification.
"SHOULD"	This word means that there may exist valid reasons in particular circumstances to ignore this item, but the full implications should be understood and the case carefully weighed before choosing a different course.
"SHOULD NOT"	This phrase means that there may exist valid reasons in particular circumstances when the listed behavior is acceptable or even useful, but the full implications should be understood and the case carefully weighed before implementing any behavior described with this label.
"MAY"	This word means that this item is truly optional. One vendor may choose to include the item because a particular marketplace requires it or because it enhances the product, for example; another vendor may omit the same item.

2 REFERENCES

At the time of publication, the editions indicated were valid. All references are subject to revision, and users of this document are encouraged to investigate the possibility of applying the most recent editions of the documents listed below. References are either specific (identified by date of publication, edition number, version number, etc.) or non-specific. For a nonspecific reference, the latest version applies.

2.1 Normative References

In order to claim compliance with this specification, it is necessary to conform to the following standards and other works as indicated, in addition to the other requirements of this specification. Notwithstanding, intellectual property rights may be required to use or implement such normative references.

- [DRFI] Downstream RF Interface Specification, CM-SP-DRFI-I14-131120, November 20, 2013, Cable Television Laboratories, Inc.
- [DTI] DOCSIS Timing Interface, CM-SP-DTI-I06-150305, March 5, 2015, Cable Television Laboratories, Inc.
- [GCP] Generic Control Plane Specification, CM-SP-GCP-I01-150615, June 15, 2015, Cable Television Laboratories, Inc.
- [G.8260] ITU-T Recommendation G.8260, Definitions and terminology for synchronization in packet networks, 2012.
- [G.8261] ITU-T Recommendation G.8261, Timing and synchronization aspects in packet networks, 2008.
- [MULPIv3.1] DOCSIS MAC and Upper Layer Protocols Interface Specification, CM-SP-MULPIv3.1-I06-150611, June 11, 2015, Cable Television Laboratories, Inc.
- [PHYv3.0] DOCSIS 3.0 Physical Layer Specification, CM-SP-PHYv3.0-I12-150305, March 5, 2015, Cable Television Laboratories, Inc.
- [PHYv3.1] DOCSIS 3.1 Physical Layer Specification, CM-SP-PHYv3.1-I06-150611, June 11, 2015, Cable Television Laboratories, Inc.
- [DOCSIS PHY] Refers to both [PHYv3.0] and [PHYv3.1].
- [IEEE 1588] IEEE-1588-2008, Standard for a Precision Clock Synchronization Protocol for Networked Measurement and Control Systems, July 2008, <http://standards.ieee.org/findstds/standard/1588-2008.html>.
- [ISO 13818-1] ISO/IEC 13818-1:2013, Information Technology – Generic Coding of Moving Pictures and Associated Audio Information. Part 1: System, May 23, 2013.
- [R-DEPI] Remote Downstream External PHY Interface Specification, CM-SP-R-DEPI-I01-150615, June 15, 2015, Cable Television Laboratories, Inc.
- [RFIV2.0] DOCSIS Radio Frequency Interface Specification, CM-SP-RFIV2.0-C02-090422, April 22, 2009, Cable Television Laboratories, Inc.
- [R-OOB] Remote Out-of-Band Specification, CM-SP-R-OOB-I01-150615, June 15, 2015, Cable Television Laboratories, Inc.
- [R-PHY] Remote PHY Specification, CM-SP-R-PHY-I01-150615, June 15, 2015, Cable Television Laboratories, Inc.
- [R-UEPI] Remote Upstream External PHY Interface Specification, CM-SP-R-UEPI-I01-150615, June 15, 2015, Cable Television Laboratories, Inc.

- [SCTE 55-1] ANSI/SCTE 55-2009, Digital Broadband Delivery System: Out of Band Transport Part 1: Mode A.
- [SCTE 55-2] ANSI/SCTE 55-2-2008, Digital Broadband Delivery System: Out of Band Transport Part 2: Mode B.

2.2 Informative References

This specification does not have any informative references.

2.3 Reference Acquisition

- Cable Television Laboratories, Inc., 858 Coal Creek Circle, Louisville, CO 80027; Phone +1-303-661-9100; Fax +1-303-661-9199; <http://www.cablelabs.com>
- Institute of Electrical and Electronics Engineers (IEEE), +1 800 422 4633 (USA and Canada); <http://www.ieee.org>
- Internet Engineering Task Force (IETF) Secretariat, 48377 Fremont Blvd., Suite 117, Fremont, California 94538, USA, Phone: +1-510-492-4080, Fax: +1-510-492-4001, <http://www.ietf.org>
- International Organization for Standardization (ISO), Tel.: +41 22 749 02 22, Fax: +41 22 749 01 55, www.standardsinfo.net
- SCTE, Society of Cable Telecommunications Engineers Inc., 140 Philips Road, Exton, PA 19341 Phone: +1-800-542-5040, Fax: +1-610-363-5898, Internet: <http://www.scte.org/>

3 TERMS AND DEFINITIONS

This specification uses the following terms:

Cable Modem (CM)	A modulator-demodulator at subscriber locations intended for use in conveying data communications on a cable television system.
CCAP-Core	A CCAP device that uses MHA v2 protocols to interconnect to an RPD.
Converged Interconnect Network	The network (generally gigabit Ethernet) that connects a CCAP-Core to an RPD.
Customer Premises Equipment (CPE)	Equipment at the end user's premises; may be provided by the service provider.
Data Rate	Throughput, data transmitted in units of time usually in bits per second (bps).
Decibels (dB)	Ratio of two power levels expressed mathematically as $\text{dB} = 10\log_{10}(P_{\text{OUT}}/P_{\text{IN}})$.
Decibel-Millivolt (dBmV)	Unit of RF power expressed in decibels relative to 1 millivolt, where $\text{dBmV} = 20\log_{10}(\text{value in mV}/1 \text{ mV})$.
Downstream (DS)	<ol style="list-style-type: none"> 1. Transmissions from CMTS to CM. This includes transmission from the CMTS Core to the RPD, as well as the RF transmissions from the RPD to the CM. 2. RF spectrum used to transmit signals from a cable operator's headend or hub site to subscriber locations.
Edge QAM modulator (EQAM)	A headend or hub device that receives packets of digital video or data. It re-packetizes the video or data into an MPEG transport stream and digitally modulates the digital transport stream onto a downstream RF carrier using quadrature amplitude modulation (QAM).
Flow	A stream of packets in [R-DEPI] used to transport data of a certain priority from the CMTS Core to a particular QAM channel of the RPD. In PSP operation, there can exist several flows per QAM channel.
Gbps	Gigabits per second
Gigahertz (GHz)	A unit of frequency; 1,000,000,000 or 10^9 Hz.
GigE (GE)	Gigabit Ethernet (1 Gbps)
Hertz (Hz)	A unit of frequency; formerly cycles per second.
Hybrid Fiber/Coax (HFC) System	A broadband bidirectional shared-media transmission system using optical fiber trunks between the head-end and the fiber nodes, and coaxial cable distribution from the fiber nodes to the customer locations.
Institute of Electrical and Electronic Engineers (IEEE)	A voluntary organization which, among other things, sponsors standards committees and is accredited by the American National Standards Institute (ANSI).
Internet Engineering Task Force (IETF)	A body responsible for, among other things, developing standards used in the Internet.
Internet Protocol (IP)	An Internet network-layer protocol
kilohertz (kHz)	Unit of frequency; 1,000 or 10^3 Hz; formerly kilocycles per second
MAC Domain	A grouping of layer 2 devices that can communicate with each other without using bridging or routing. In DOCSIS is the group of CMs that are using upstream and downstream channels linked together through a MAC forwarding entity.
Maximum Transmission Unit (MTU)	Maximum size of the layer 3 payload of a layer 2 frame.

Mbps	Megabits per second
Media Access Control (MAC)	Used to refer to the Layer 2 element of the system which would include DOCSIS framing and signaling.
Megahertz (MHz)	A unit of frequency; 1,000,000 or 10^6 Hz; formerly megacycles per second
Microsecond (μs)	10^{-6} second
Millisecond (ms)	10^{-3} second
Modulation Error Ratio (MER)	The ratio of the average symbol power to average error power.
Multiple System Operator (MSO)	A corporate entity that owns and/or operates more than one cable system.
Nanosecond (ns)	10^{-9} second
Physical Media Dependent (PMD) Sublayer	A sublayer of the Physical layer which is concerned with transmitting bits or groups of bits over particular types of transmission link between open systems and which entails electrical, mechanical, and handshaking procedures.
QAM channel (QAM ch)	Analog RF channel that uses quadrature amplitude modulation (QAM) to convey information
Quadrature Amplitude Modulation (QAM)	A modulation technique in which an analog signal's amplitude and phase vary to convey information, such as digital data.
Radio Frequency (RF)	In cable television systems, this refers to electromagnetic signals in the range 5 to 1000 MHz.
Radio Frequency Interface	Term encompassing the downstream and the upstream radio frequency interfaces.
Remote PHY Device	The Remote PHY Device (RPD) is a device in the network that implements the Remote-PHY/MHA v2 specifications to provide conversion from digital Ethernet transport to analog RF transport.
Timebase	The clock from which all other internally generated clocks and timebases on the device are derived
Upconverter	A device used to change the frequency range of an analog signal, usually converting from a local oscillator frequency to an RF transmission frequency.
Upstream (US)	<ol style="list-style-type: none"> 1. Transmissions from CM to CMTS. This includes transmission from the RPD to the CMTS Core as well as the RF transmissions from the CM to the RPD. 2. RF spectrum used to transmit signals from a subscriber location to a cable operator's headend or hub site.
Upstream Channel Descriptor (UCD)	The MAC Management Message used to communicate the characteristics of the upstream physical layer to the cable modems.

4 ABBREVIATIONS AND ACRONYMS

This specification uses the following abbreviations:

μs	Microsecond
ATP	Acceptance test plan
BC	Boundary clock
CBR	Constant bit rate
CCAP™	Converged cable access platform
CIN	Converged interconnect network
CLK	Clock
CM	Cable modem
CMCI	Cable modem CPE interface
CMTS	Cable modem termination system
CPE	Customer premises equipment
dB	Decibel
dBc	Decibel carrier
dBmV	Decibel millivolt
DCA	Distributed CCAP Architecture
DEPI	Downstream External-PHY Interface Specification
DLM	DEPI latency measurement
DOCSIS	Data-Over-Cable Service Interface Specifications
DRFI	[DOCSIS] Downstream Radio Frequency Interface (specification)
DS	Downstream
DTI	DOCSIS Timing Interface (specification)
DTP	DOCSIS timing protocol
EEC	Ethernet equipment clock
EQAM	Edge-QAM (modulator)
FEC	Forward error correction
FFO	Fractional frequency offset
FIFO	First in first out
FTP	File transfer protocol
GCP	Generic control plane
GM	Grandmaster
GPS	Global Positioning System
HA	High availability
HFC	Hybrid fiber/coax
HRM	Hypothetical reference model
HTTP	Hypertext transfer protocol
Hz	Hertz
IEEE	Institute of Electrical and Electronics Engineers
IETF	Internet Engineering Task Force

IP	Internet protocol
IPv4	Internet protocol version 4
IPv6	Internet protocol version 6
ITU	International Telecommunication Union
ITU-T	ITU Telecommunication Standardization Sector
kHz	Kilohertz
log	Logarithm
MAC	Media access control
MAP	Upstream Bandwidth Allocation Map (referred to only as MAP)
MHA v2	Modular Headend Architecture Version 2
MHz	Megahertz
MPEG	Moving Picture Experts Group
MPEG-TS	MPEG transport stream
MPT	MPEG-TS payload type
MPTS	Multi program transport stream
MSO	Multiple system operator
MTIE	Maximum time interval error
NDF	Narrowband digital forward
NDR	Narrowband digital return
ns	Nanosecond
NSI	Network side interface
NTP	Network time protocol
OOB	Out of Band
OC	Ordinary clock
OFDM	Orthogonal frequency division multiplexing
OSSI	Operations System Support Interface
PCR	Program clock reference
PDV	Packet delay variation
PHY	Physical layer
PLC	PHY link channel
PPB	Parts per billion
PPM	Parts per million
PRC	Primary reference clock
PTP	Precision time protocol
QAM	Quadrature amplitude modulation
R-DTI	Remote DOCSIS Timing Interface (specification)
RPD	Remote PHY Device
RF	Radio frequency
REQ	Request
RFI	Radio frequency interface
RMS	Root mean square

RNG-RSP	Ranging response
RX	Receiver
SyncE	Synchronous Ethernet
STC	System timing clock
TAI	International Atomic Time
TC	Transparent clock
TCP	Transmission control protocol
TDM	Time division multiplexing
TDMA	Time division multiple access
ToD	Time of day
TS	Timestamp
TSMB	Timestamp message block
TWTT	Two-way time transfer
UEPI	Upstream external PHY interface
US	Upstream
UTC	Coordinated Universal Time

5 OVERVIEW

5.1 Introduction

The requirements for timing and synchronization of the MHA v2 architecture come from the following areas.

- Existing DOCSIS specification requirements
- Remote PHY system requirements
- Implementation requirements
- Precision timing services like T-services and wireless backhaul

These requirements place definitions and constraints on the use of the DOCSIS master clock and the DOCSIS timestamp.

As shown as Figure 1, in the MHA v2 architecture, the CMTS Core and the RPD are two entities located in separate chassis, and potentially in different physical locations. The DS PHY and US PHY are located on one assembly—the Remote PHY Device—controlled with a common clock. The upstream scheduler/MAP builder is part of media access control (MAC), and is located at the CMTS Core. The DOCSIS time described by the MAP needs to allow correct burst reception at the RPD. Therefore the CMTS Core and the RPD need to have a common knowledge of the DOCSIS time. Without any synchronization method, the CMTS Core and the RPD run on separate timing domains based on their own local clocks. There will be an offset between CMTS Core DOCSIS timestamp and the RPD DOCSIS timestamp. This offset is not constant but increases or decreases over time because of the drift accumulation caused by the frequency accuracy difference of the two local clocks.

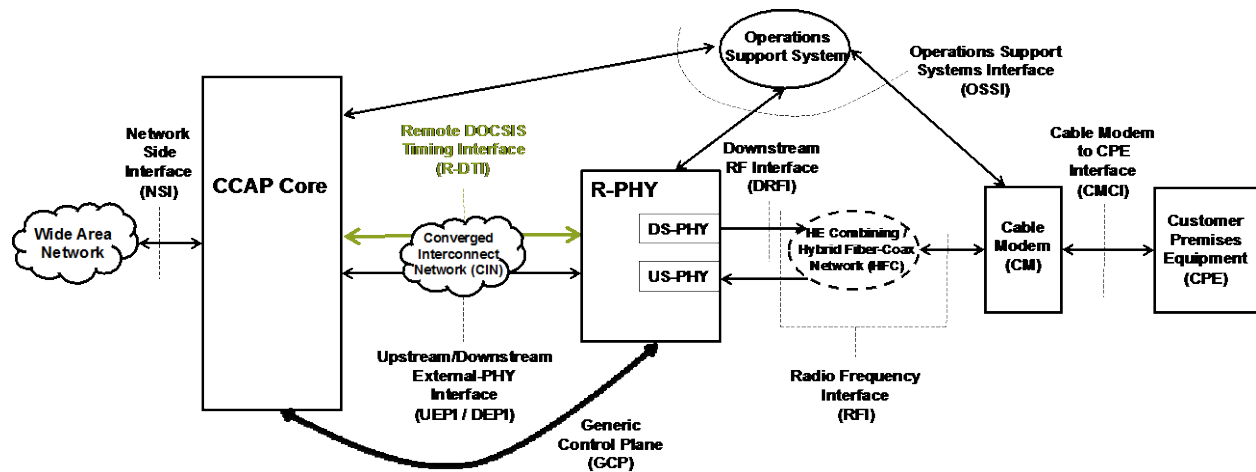

Figure 1 - MHA v2 Reference Architecture for Remote PHY

Similar challenges exist for video and OOB services. The Remote DOCSIS Timing Interface (R-DTI) protocol defined in this document supports the basic synchronization between the CCAP-Core and RPD for DOCSIS/video/OOB services and the precision time synchronization for emerging services such as wireless backhaul.

5.2 DOCSIS

5.2.1 System Requirements

The R-DTI system requirements refer to the DOCSIS timing requirements outlined in the DOCSIS specifications. These requirements exist independently from the CMTS architecture, synchronization methods, or operation modes. The sections of [DRFI] that are of interest are:

- 6.3.5.2, CMTS or EQAM Master Clock Jitter for Asynchronous Operation
- 6.3.5.3, CMTS or EQAM Master Clock Jitter for Synchronous Operation
- 6.3.5.4, CMTS or EQAM Master Clock Frequency for Synchronous Operation
- 6.3.6, CMTS or EQAM Clock Generation
- 6.3.7, Downstream Symbol Clock Jitter for Synchronous Operation
- 6.3.8, Downstream Symbol Clock Drift for Synchronous Operation
- 6.3.9, Timestamp Jitter

The sections of [PHYv3.1] that are of the interest are:

- 7.5.3.1, Downstream Sampling Rate
- 7.5.3.2, OFDM RF Transmission Synchronization
- 7.5.3.3, Downstream OFDM Symbol Clock Jitter

5.2.2 Modular Implementation Requirements

5.2.2.1 Synchronization Methods

The CMTS Core element MAY achieve synchronization using one of the following methods:

1. Self-synchronization of frequency from an internal frequency source.
2. Synchronization of time from a time protocol such as Network Time Protocol (NTP) or Precision Time Protocol (PTP).
2. Synchronization of frequency and time from a local DTI server.
3. Synchronization of frequency and time from an [IEEE 1588] source connected to the CMTS Core over the packet network.
4. Synchronization of frequency from a synchronous Ethernet (SyncE) port.
5. Synchronization of frequency and time from a Global Positioning System (GPS) source.
6. Synchronization of frequency from a synchronous Ethernet port and time from an [IEEE 1588] source connected to the RPD over the packet network. The Ethernet equipment clock (EEC) and 1588 grandmaster (GM) shall share the same standard time source to avoid long-term frequency drift error.

The RPD element MAY achieve synchronization by one of the following methods:

1. Self-synchronization of frequency from an internal frequency source.
2. Synchronization of time from a time protocol such as NTP or PTP.
3. Synchronization of frequency and time from an [IEEE 1588] source connected to the RPD over the packet network.
4. Synchronization of frequency from a synchronous Ethernet port and time from an [IEEE 1588] source connected to the RPD over the packet network. The EEC and 1588 GM shall share the same standard time source to avoid long-term frequency drift error.

The cable modem (CM) element:

- Derives frequency synchronization from the DOCSIS downstream baud rate.
- Derives relative time synchronization from the DOCSIS timestamp and the DOCSIS ranging process.
- Derives ToD and precision time synchronization using the DOCSIS timing protocol (DTP).

5.2.2.2 DOCSIS Timing Operation

The CMTS Core element may choose one of the following modes of operation depending on its own synchronization capability and/or the RPD's synchronization capability:

- CMTS Core is the timing master. The DOCSIS scheduler receives the REQ messages from the CM and uses a local timestamp to generate the MAP.
- RPD is the timing master. The DOCSIS scheduler receives the REQ messages from the CM and uses a recovered timestamp from the RPD to generate the MAP.

The RPD element:

- Uses a local time and frequency source to generate the DOCSIS timestamp and inject it into the DOCSIS downstream path.
- Uses the same DOCSIS timestamp to receive packets on an upstream receiver interface.

5.2.3 System Description

5.2.3.1 IEEE 1588 Utilization

IEEE 1588 provides time synchronization between two nodes across a packet network without mandating all intermediate nodes being replaced, hence becomes the best tool for the R-DTI implementation. [IEEE 1588] standardizes the PTP and the node, system and communication properties necessary to support PTP. Only the most relevant and basic information is listed here. For the detailed information, please refer to [IEEE 1588] directly.

5.2.3.1.1 PTP Devices

A Precision Time Protocol (PTP) system is a distributed, networked system consisting of a combination of PTP and non-PTP devices. PTP devices include ordinary clocks (OC), boundary clocks (BC), end-to-end transparent clocks (TC), peer-to-peer transparent clocks, and management nodes. Non-PTP devices include bridges, routers, and other infrastructure devices that do not generate, modify, or consume PTP messages.

The PTP devices that are most relevant to R-DTI are OCs and BCs.

5.2.3.1.1.1 Ordinary Clock

An ordinary clock (OC) communicates with the network via two logical interfaces based on a single physical port. The event interface is used to send and receive event messages, which are timestamped by the timestamp generation block based on the value of the local clock. The general interface is used to send and receive general messages. An OC in a domain supports a single copy of the protocol and has a single PTP state. The OC can be the GM clock in a system, or it can be a slave clock in a master-slave hierarchy. It contains a protocol engine and has the following functions:

- Sends and receives PTP messages
- Maintains the data sets
- Executes the state machine associated with the port
- If the port is in the slave state (synchronized to a master), it computes the master's time based on the received PTP timing messages and timestamps that were generated.

The control loop in the local clock adjusts the clock to agree with the time of its master if the OC port is in the slave state. If the port is in the master state, the local clock is free running or possibly synchronized to an external source of time such as GPS. If the port is in the master state and the OC is the GM clock of the domain, then the local clock is typically synchronized to an external source of time traceable to International Atomic Time (TAI) and Coordinated Universal Time (UTC), such as a GPS-based system.

5.2.3.1.1.2 Boundary Clock

The boundary clock (BC) typically has several physical ports with each physical port communicating with the network via two logical interfaces: event and general. Each port of a BC is like the port of an OC, with the following exceptions:

1. The clock data sets are common to all ports of the BC.
2. The local clock is common to all ports of the BC.
3. Each protocol engine has the additional function of resolving the states of all ports to determine which port provides the time signal used to synchronize the local clock.

5.2.3.1.2 PTP Messages

The PTP defines event and general PTP messages. Event messages are timed messages in that an accurate timestamp is generated at both transmission and receipt. General messages do not require accurate timestamps. The set of event messages consists of:

- Sync
- Delay_Req
- Pdelay_Req
- Pdelay_Resp

The set of general messages consists of:

- Announce
- Follow_Up
- Delay_Resp
- Pdelay_Resp_Follow_Up
- Management
- Signaling

Among these messages, the Sync, Delay_Req, Follow_Up, and Delay_Resp messages are used to generate and communicate the timing information needed to synchronize ordinary and boundary clocks using the delay request-response mechanism.

Figure 2 illustrates the basic synchronization message exchange. The messages exchange pattern is as follows:

1. The master sends a Sync message to the slave and notes the time $t1$ at which it was sent.
2. The slave receives the Sync message and notes the time of reception $t2$.
3. The master conveys to the slave the timestamp $t1$ by:
 - a. Embedding the timestamp $t1$ in the Sync message. This requires some sort of hardware processing for highest accuracy and precision.
 - b. Embedding the timestamp $t1$ in a Follow_Up message.
4. The slave sends a Delay_Req message to the master and notes the time of delivery $t3$.
5. The master conveys to the slave the timestamp $t4$ by embedding it in a Delay_Resp message.

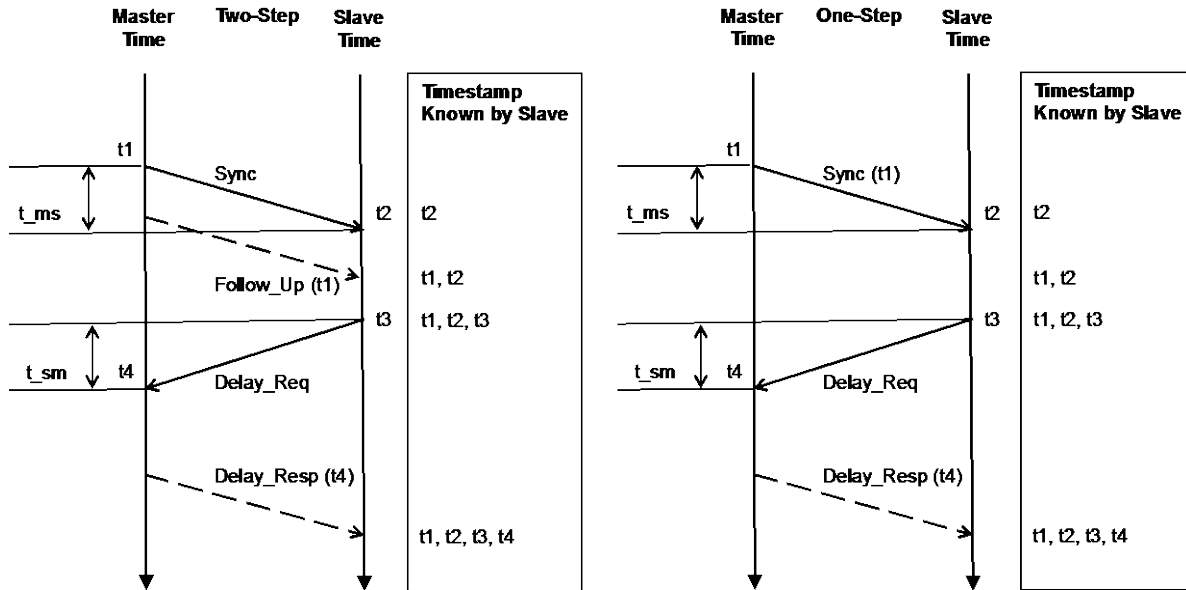

Figure 2 - PTP Basic Synchronization Message Exchange

At the conclusion of this exchange of messages, the slave possesses all four timestamps. These timestamps may be used to compute the offset of the slave’s clock with respect to the master and the mean propagation time of messages between the two clocks.

The computation of offset and propagation time assumes that the master-to-slave and slave-to-master propagation times are equal. Any asymmetry in propagation time introduces an error in the computed value of the clock offset. The computed mean propagation time differs from the actual propagation times due to the asymmetry.

The details of all the messages are described in [IEEE 1588].

5.2.3.1.3 Achieving Frequency Synchronization

Without frequency synchronization, the master and slave clocks will drift apart between message updates. Because the sync messages are sent repetitively, the slave is able to calculate the drift between the master clock and slave clock with the following formula

$$Drift = \frac{\Delta t2(m, n) - \Delta t1(m, n)}{\Delta t1(m, n)}$$

$\Delta t1(m, n)$ is the original timestamp difference (@master) of the two Sync messages with multiple Sync messages in between, and $\Delta t2(m, n)$ is the arrival timestamp (@slave) difference of the two Sync messages. By comparing the drift over time, the slave can synthesize a frequency that is synchronized to the master clock.

Frequency recovery is only required if alternate frequency traceability methods, such as Synchronous Ethernet, do not exist and high levels of time accuracy are required. If Layer 1 frequency synchronization is available, it should be used since it provides a higher level of frequency accuracy and stability.

5.2.3.1.4 Achieving Time Synchronization

Once frequency synchronization is achieved, the slave clock can maintain a constant phase relationship to the master clock; then the delay request-response mechanism is used to measure the <meanPathDelay> between the master and clock. PTP assumes that the delays from the master to the slave and from the slave to the master are perfectly symmetrical, allowing the meanPathDelay to be calculated using the following formula:

$$\langle meanPathDelay \rangle = \frac{[(t2 - t1) + (t4 - t3)]}{2} = \frac{[t2 - t3] + (t4 - t1)]}{2}$$

The value of the slave time on the next $t2$ time is calculated with:

$$T_{slave} @ t2 = t1 + \langle meanPathDelay \rangle$$

Time recovery can require a very complex algorithm that is affected by many real world effects such as slight variations in frequency, packet delay variation (PDV), and network asymmetry.

5.2.3.1.5 Time Synchronization Error Sources

There are three main sources of error for time synchronization in any two-way time transfer (TWTT) protocol including PTP. These are described in the following subsections.

5.2.3.1.5.1 Fixed Path Asymmetry

Because PTP assumes that the master-to-slave (t_{ms}) and slave-to-master (t_{sm}) paths are perfectly symmetrical, any asymmetry in the paths will result in a time offset between the master and slave nodes equal to the following basic formula:

$$t_{error} = \frac{t_{ms} - t_{sm}}{2}$$

The asymmetry can arise from many sources, including but not limited to:

- Network topology differences;
- Timestamp location differences within the master, slave, or transparent clock nodes;
- Node delay variations through nonparticipant nodes.

5.2.3.1.5.2 Packet Delay Variation (PDV)

Because time synchronization relies on constant flight time between the master and slave, any variability in packet delivery in either direction will make it more difficult for the slave to accurately recover time and frequency. Each calculation of drift, offset and one-way delay will produce unique results based on the PDV in the network.

Therefore, slaves use a slave servo algorithm to integrate the results to determine the true offset and one-way delay measurements over time. Alternatively a slave servo algorithm could pre-process the time values before calculating the offset drift and one-way delay, looking for minimum packet delays.

The algorithm is not standardized as part of [IEEE 1588].

5.2.3.1.5.3 Frequency Drift Between Master and Slave

In between time updates from the slave servo algorithm, PTP time is advancing based on the slave's holdover frequency. If the frequency at the master and the slave are not perfectly synchronized, the time at the slave will drift away from the master time. The rate of drift is proportional to the frequency difference.

If the frequency on the slave is recovered from the packet timing flow, as with PTP, then the accuracy of the frequency recovery will be impacted by the PDV through the network.

5.2.3.2 Timestamp Conversion

It is important to recognize that the PTP timestamp, DOCSIS 3.0 timestamp, and DOCSIS 3.1 extended timestamp are interchangeable as shown in Figure 3. This allows the utilization of 1588/PTP in the DOCSIS synchronization. All elements in the R-DTI system MUST maintain the integrity between those timestamp formats.

In summary, 1588/PTP utilization in the R-DTI is not only a solution but also a desirable solution, as the 1588/PTP is a well defined protocol, a proven design utilized by multiple industries, and there are existing hardware and technologies that make the implementation relatively smooth and predictable.

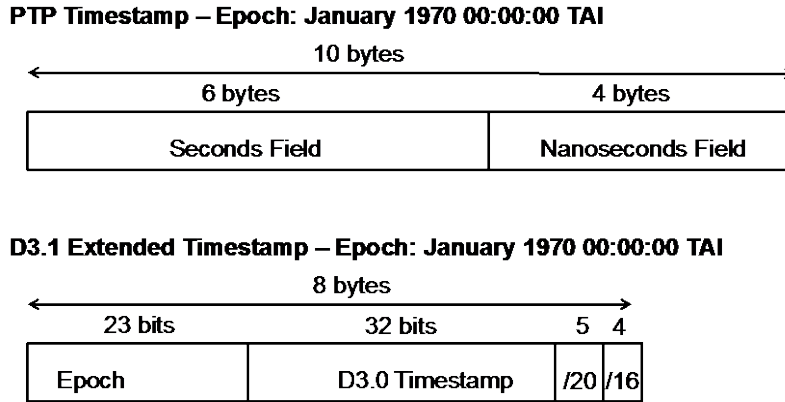

Figure 3 - PTP Timestamp, DOCSIS 3.0 Timestamp and DOCSIS 3.1 Extended Timestamp

5.2.3.3 Operation Mode – Node_Slave

Figure 4 shows frequency and phase distribution between the CMTS Core and the RPD with the RPD being the timing slave.

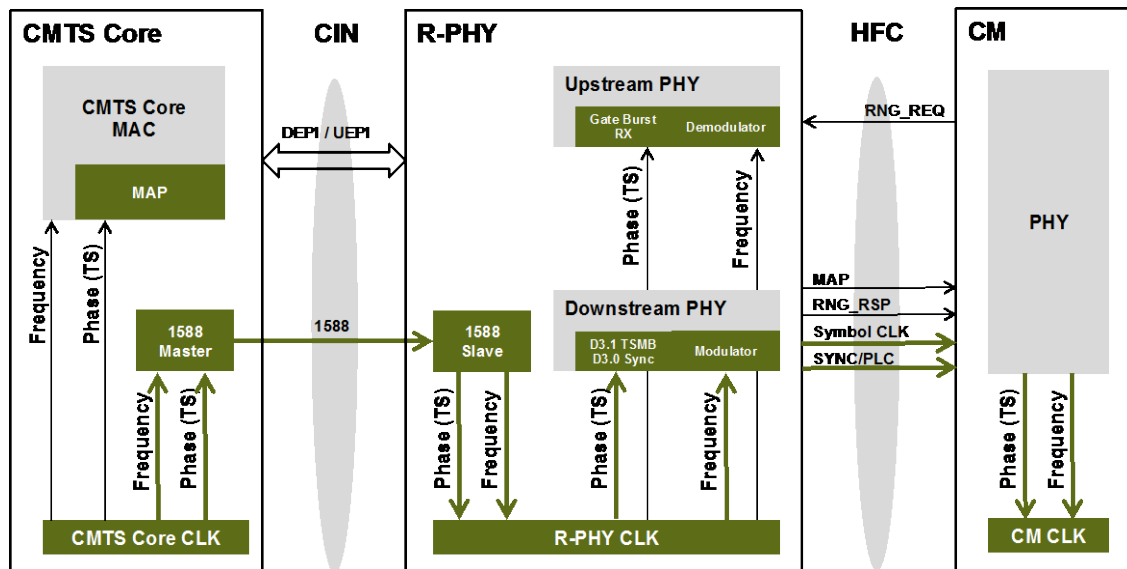

Figure 4 - R-DTI Node_Slave Architecture – RPD Slave / Core Master

The Node_Slave mode is a typical 1588/PTP application, and the key element of this architecture is to have a single clock domain system; both frequency and phase of the RPD and the CMTS Core are synchronized. One way to achieve this goal is to make the CMTS Core the 1588 master and the RPD the 1588 slave as shown in Figure 4. Alternatively, they can both be 1588 slaves and synchronize to a 1588 GM in a single 1588 clock domain, as shown in Figure 5. In this architecture, the synchronization mode is linked with the DOCSIS operation mode. The CMTS Core and the RPD have to be in the same PTP clock domain.

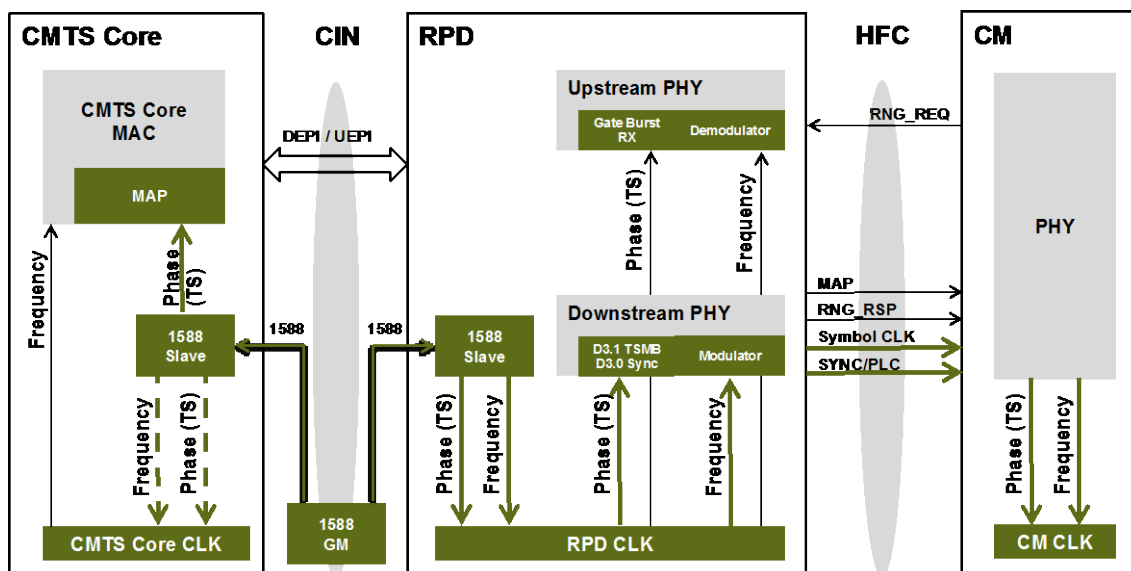

Figure 5 – R-DTI Node_Slave Architecture – RPD Slave / Core Slave / Common Master

Figure 6 shows the basic synchronization message exchange in the R-DTI Node_Slave architecture. Refer to Section 5.2.3.1.3 and Section 5.2.3.1.4 for information on achieving frequency and time synchronization using PTP messages.

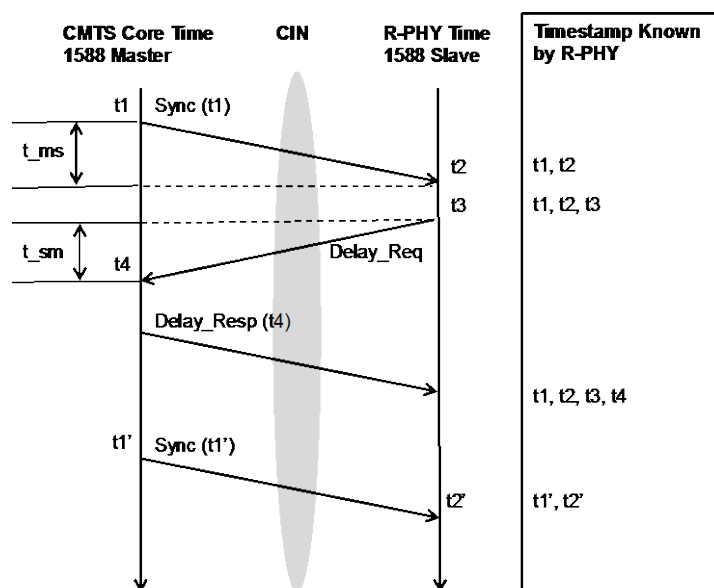

Figure 6 - Basic Synchronization Message Exchange in Node_Slave Mode

5.2.3.3.1 Performance Consideration

In Node_Slave mode, both the DOCSIS master clock frequency and the DOCSIS timestamp are driven by the PTP source, and MUST meet all applicable [DRFI] and [DOCSIS PHY] requirements.

The phase/time accuracy of the synchronization impacts the Request_Grant round trip delay and MAP advance calculation. The synchronization error needs to be considered as part of engineering margin for MAP advance calculation as described in Appendix I, RPD and DOCSIS System Performance.

The timestamp error between the CMTS Core and the RPD depends on many factors including—but not limited to—the following:

- The timestamp mechanism. The timestamp shall be performed as close as possible to the physical interface to minimize the PDV inside the devices.
- The CIN characteristic. The performance is impacted by the path asymmetry and the PDV in the network.
- Algorithms at the RPD. In order to minimize the impact from the packet network using PTP packets, specific algorithms may need to be implemented at the RPD to guarantee frequency and phase performance.

5.2.3.3.2 DLM Utilization

In the Node_Slave operation mode, full time synchronization can be achieved and the DEPI latency measurement (DLM) protocol specified in Remote Downstream External PHY Interface [R-DEPI] specification can be utilized to measure the CIN delay. The DLM is important because it prevents overestimating and/or underestimating the network delay effect, and therefore improves efficiency without compromising reliability. It is important to recognize that PTP is not an alternative to DLM for these reasons:

- Only PTP slaves, but not masters, are aware of all timestamps required for the latency measurement. In DOCSIS, CMTS Core needs to obtain the latency information to calculate MAP advance, and as PTP master it does not have enough information to do so. DLM, on the other hand, makes the timestamp information available to the master.
- DLM offers different reference points regarding timestamp compared to PTP.

5.2.3.4 Operation Mode - Node_Master

Figure 7 shows frequency and phase distribution between the CMTS Core and the RPD with the RPD being the timing master.

Figure 7 - R-DTI Node_Master Architecture – RPD as the Timing Master

In the Node_Master architecture, the RPD acts as a 1588 Master, while CMTS Core acts as a 1588 Slave.

The RPD distributes its frequency and phase information through PTP. CMTS Core MAC obtains the frequency and phase information from the timestamp messages and runs a phase calibration process to track the RPD time without achieving frequency synchronization.

The CMTS Core MAC timestamp is still driven by the CMTS Core system clock frequency, however the new timestamp values recovered from the RPD PTP messages are loaded periodically, so the MAC timestamp gets corrected before it drifts too far away from the RPD timestamp. To give an example, if the CMTS Core local clock frequency accuracy is +5 parts per million (PPM), and the RPD clock frequency accuracy is -5PPM, and the update frequency is set to once per second, then the CMTS Core MAC timestamp will be 10 μ s ahead of the RPD timestamp at the end of that 1 second interval even if they were perfectly aligned at the beginning of the interval. They will be aligned again when another update occurs.

The RPDs can be on different clock domains—for example, each running on its own oscillator—so the CMTS Core needs to track each individual RPD clock domain separately. The CMTS Core becomes an ordinary clock (slave) in each 1588 clock domain, but it may participate in hundreds or even thousands of 1588 clock domains at the same time.

The RPD may be in a free run mode with its frequency driven from an internal frequency source such as an oscillator, and its time driven from a time protocol such as NTP. Or it may synchronize to a 1588 GM in the packet network for both frequency and time. In the latter case, the RPD is a 1588 BC instead of OC—it is a slave clock to the 1588 GM in the network and a master clock to the CCAP-Core. Similarly, the CMTS Core may be in a free run mode or synchronized to an external source.

NOTE: The synchronization modes of either or both entities (CMTS Core or RPD) do not impact the DOCSIS operation when the Node_Master mode is chosen.

5.2.3.4.1 Synchronization Message Exchange

Figure 8 shows the basic synchronization message exchange in the R-DTI Node_Master architecture. Refer to Section 5.2.3.1.3 and Section 5.2.3.1.4 on achieving frequency and time synchronization using PTP messages. Although the physical frequency of the CMTS Core is not synchronized to the RPD clock, the drift information may be used to better estimate the time.

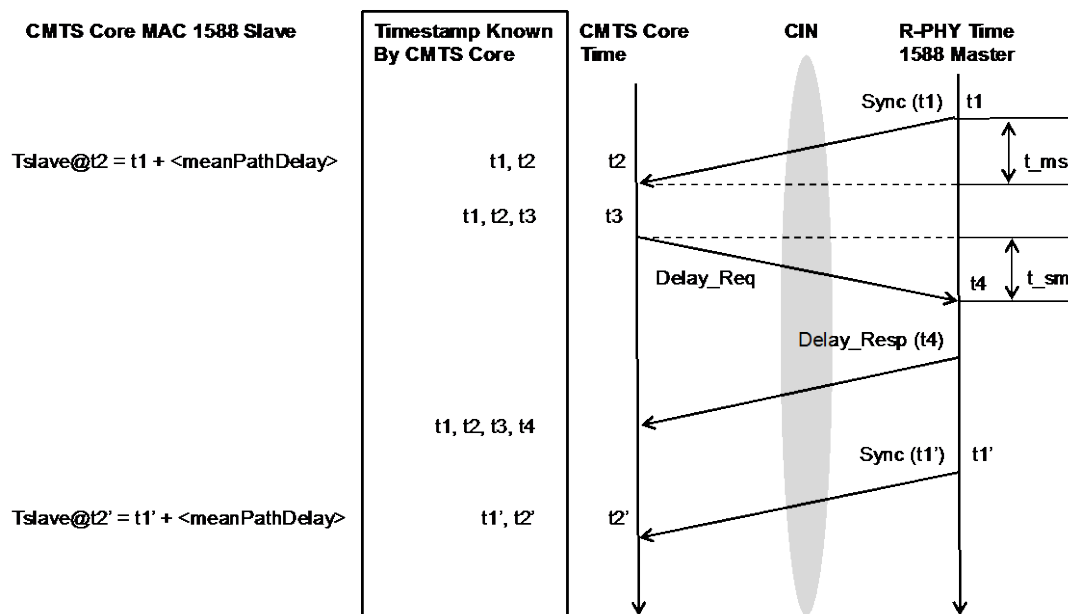

Figure 8 - Basic Synchronization Message Exchange in Node_Master Mode

5.2.3.4.2 Performance Consideration

There is no actual physical frequency synchronization in this architecture (Node_Master mode); therefore frequency stability is less of a concern.

Similarly to the Node_Slave mode, the accuracy of the synchronization impacts the Request_Grant round trip delay and MAP advance calculation. The synchronization accuracy can be affected by many factors such as timestamp mechanism, network topology, traffic behavior, client algorithms, etc.

Since the physical frequency between the two entities is not in sync in this mode, the drift accumulation due to the frequency offset of the two between the updates could contribute to additional phase error compared to the Node_Slave mode.

5.2.3.4.3 High Availability Consideration

To be added.

5.2.3.5 DOCSIS Deployment Scenarios

5.2.3.5.1 Co-existing Operation Modes in a Single CMTS System

The operation modes described in Section 5.2.3.3 and Section 5.2.3.4 can co-exist in a single CMTS system. The example is shown in Figure 9. Each color represents one 1588 clock domain.

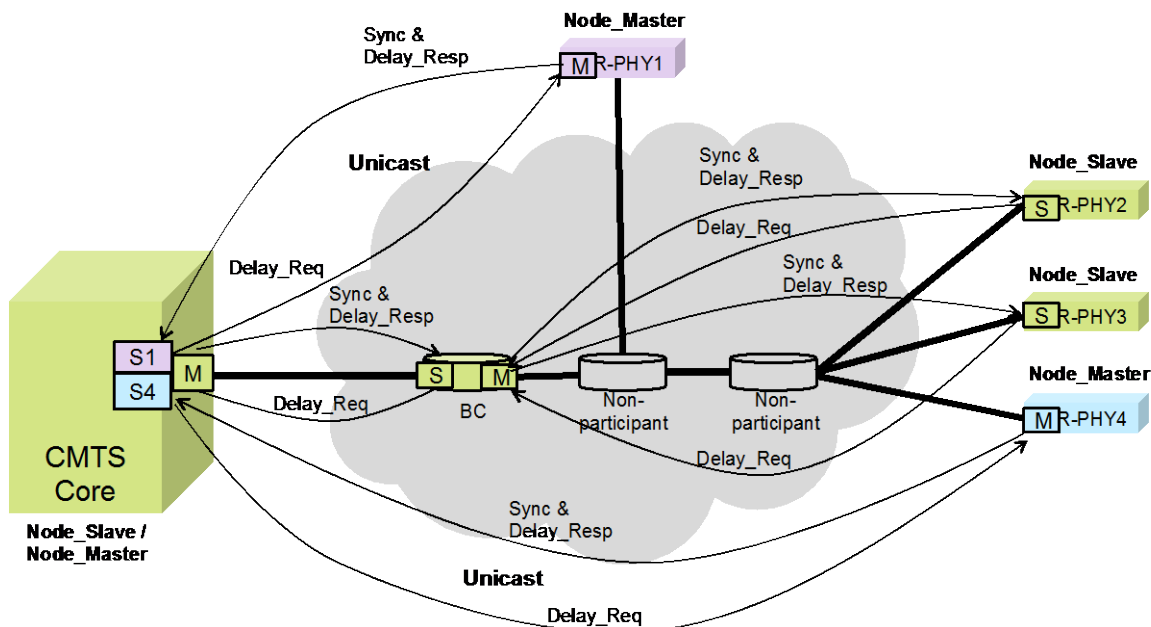

Figure 9 - Operation Modes Co-existing in a Single CMTS System

The RPDs R-PHY2 and R-PHY3 (shown in light green in Figure 9) operate as 1588 slaves and synchronize to a 1588 master clock—the BC node in the network, and the BC node synchronizes to the CMTS Core. The CMTS Core acts as the 1588 grandmaster clock of this 1588 clock domain. The DOCSIS operation mode between CMTS Core and RPDs R-PHY2 and R-PHY3 is Node_Slave mode.

At the same time, the CMTS Core is a 1588 slave clock to RPD R-PHY1, and also a 1588 slave clock to RPD R-PHY4. The DOCSIS operation mode between CMTS Core and RPDs R-PHY1 and R-PHY4 is Node_Master mode.

There are three independent clock domains in Figure 9. The 1588 protocol between CMTS Core and RPD R-PHY1 is established in a unicast model so the BC nodes between the two can forward the message accordingly. A unicast model SHALL be considered for all Node_Master operations unless the 1588-aware nodes in the CIN can be configured as 1588 Transparent Clocks.

5.2.3.5.2 DOCSIS Operation with Multiple CMTS Cores

Figure 10 shows the deployment example with multiple CMTS Cores. Each color represents one 1588 clock domain.

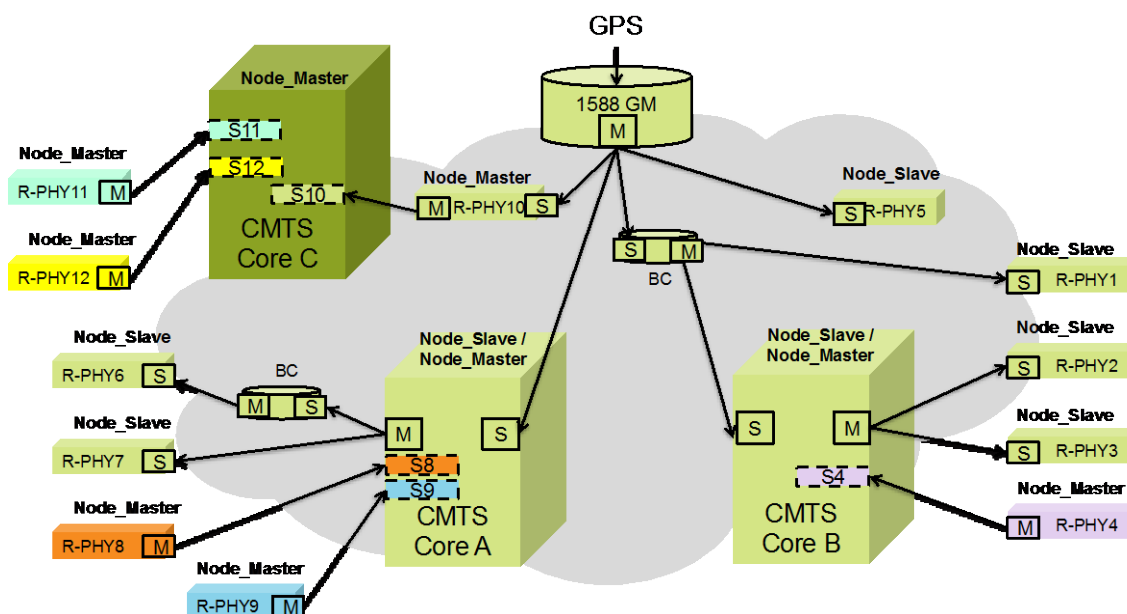

Figure 10 - Deployment Example with Multiple CMTS Cores

CMTS Core A and CMTS Core B are in the same 1588 clock domain, therefore all the RPDs that operate in Node_Slave mode to these two Cores are in the same clock domain. If CMTS Core A goes down, and the RPDs R-PHY6/7 are routed to CMTS Core B instead, the synchronization between the RPDs R-PHY6/7 and CMTS Core B is established already, and theoretically it takes less time to resume the services. In reality, the service recovery time will depend on many factors.

The CMTS Core C is not part of the same 1588 clock domain. It may not have a qualified DOCSIS master clock, but RPDs R-PHY10/11/12 can operate with CMTS Core C by operating in Node_Master mode. At the same time, RPD R-PHY10 can offer precision timing services by synchronizing to the other 1588 clock domain with traceability to a standard time source.

5.2.3.5.3 Operation Mode Negotiation between CMTS Core and RPD

The CMTS Core initiates the operation mode negotiation with the RPD. The RPD MUST respond with its capability. CMTS Core determines which operation mode to use based on the RPD's and its own capabilities, then delivers the decision to the RPD. Refer to the [GCP] specification for details.

NOTE: Changing operation mode can be disruptive to the services.

5.3 Precision Timing Synchronization Services

5.3.1 Market Forces Drive Need for Precise Timing

In recent years, synchronization in access networks has become an important topic because of the evolution from time division multiplex (TDM)-based to packet-based networks. In particular, mobile wireless operators are struggling to increase their backhaul capacity that is required by the newest radio technologies. They are pushing themselves in order to provide greater bandwidth and improved services—things that are important to their customers.

Although the introduction of smaller capacity base stations (namely microcell, picocell, and femtocell) permits mobile and broadcast operators to improve wireless service by providing better coverage, it also requires increasing the number of network connections. Such trends lead to optimization of the mobile backhaul infrastructure. Various transmission options for the aggregation networks are being considered and/or utilized. As one of the last mile access transport technologies, the cable industry's hybrid fiber coax (HFC) networks are being considered, especially as the bandwidth of DOCSIS-based systems continues to increase.

One critical aspect of mobile base stations and broadcast transmitters is their need to synchronize their radio interfaces. Accurate frequency synchronization among base stations allows user handsets to seamlessly handover between base stations, reduces interference between cells, and optimizes radio bandwidth capacity. Another critical aspect of some base stations is the need for phase or ToD synchronization. In order to be utilized in the wireless market space, DOCSIS needs to support precision time synchronization.

5.3.2 DTP and R-DTI

The DOCSIS Timing Protocol (DTP) defined in DOCSIS MULPIv3.1 is a set of techniques coupled with extensions to the DOCSIS signaling messages. DTP allows the timing and frequency system of DOCSIS to be interfaced to external timing protocols such as PTP with high accuracy. The RPD MUST support DTP for the applications that require precision synchronization.

Supporting DTP alone is not adequate when the CMTS is divided into two entities: the CMTS Core and the RPD. In order to maintain the network traceability and high accuracy of the DTP, the R-DTI is defined to offer a highly accurate synchronization method between a precision time source and the network side interface (NSI) of the RPD.

5.3.3 Time Synchronization at NSI of RPD

5.3.3.1 Frequency Synchronization

As defined in [G.8261], two main classes of synchronization methods are identified in the Ethernet network, where the RPD is deployed with:

- Plesiochronous and network synchronous methods (i.e., a reference timing signal distributed over the synchronous physical layer). Synchronous Ethernet network is defined for this case.
- Packet-based methods. (PTP is one of the methods.)

Which methods are supported by the RPD node depends on the level of accuracy required by various applications.

5.3.3.1.1 Synchronous Ethernet

A Layer 1 frequency synchronization technique provides a higher level of frequency accuracy and stability, and as a result, a higher level of time accuracy becomes possible as well. Synchronous Ethernet is designed to deliver a physical layer clock through the network. A reference timing signal traceable to a PRC is injected into the Ethernet switch using an external clock port. This signal is extracted and processed via a synchronization function before injecting timing onto the Ethernet bit stream. The synchronization function provides filtering and may require holdover.

First defined in G.8261 (2006), then complemented by ITU-T G.8261(2008), G.8262, G.8264 and a new release of G.781, Synchronous Ethernet specifies not only the method and requirements for frequency recovery and transmission, but also standardizes the advertisement of clock quality through the network. Like all Layer 1 frequency synchronization techniques, all network elements between network segments need to be capable of recovering and passing the frequency downstream. Therefore, changing a path from Ethernet to synchronous Ethernet requires all nodes in-line to be changed to use Ethernet equipment clock (EEC).

Synchronous Ethernet provides frequency traceability but not time information. Combined with IEEE 1588, and assuming careful planning and implementation, a very accurate time synchronization between two nodes across a packet network is achievable. When the frequency synchronization is implemented through synchronous Ethernet, and the phase/ToD synchronization is achieved through IEEE 1588, the EEC and 1588 GM share the same standard time source to avoid long-term frequency drift error.

5.3.3.1.2 Precision Time Protocol

PTP (see [IEEE 1588]) can be used to achieve frequency synchronization, as discussed in Section 5.2.3.1.3. ITU-T G.8261.1 specifies the hypothetical reference model (HRM) and the PDV network limits applicable when frequency synchronization is carried via packets and is recovered according to the adaptive clock recovery method as defined in Recommendations [G.8261] and [G.8260].

5.3.3.2 Phase/ToD Synchronization

While synchronous Ethernet only offers frequency traceability, The PTP (see [IEEE 1588]) can be used to achieve both frequency and phase synchronization as mentioned in Section 5.2.3.1.4. The 1588 Master Clock with a precision time source MAY be the CMTS Core or MAY be provided by other elements in the network. The devices between the master clock and RPD (slave clock) MAY be non-participant nodes, BCs, or TCs.

Non-participant nodes can introduce large amount of PDV that impacts the stability and/or the accuracy of the synchronization.

[IEEE 1588] boundary clocks (described in Section 5.2.3.1.1.2) can be used to divide the PDV effects into smaller segments and to increase the scale of 1588 deployments by distributing the burden of packet generation to multiple nodes within the network. Unfortunately, because boundary clocks are susceptible to the same error contributions as a slave node, they may actually have a negative impact on time alignment through the network. In between message updates, the boundary clock operates in holdover and therefore induces time and frequency error proportional to its onboard oscillator quality and slave servo algorithm.

Another type of PTP device is a transparent clock. It can be used in-line between a master port and slave port to provide PDV information to the slave. This technique enables an increase to the maximum number of nodes between a master and a slave with the same accuracy, or to increase the accuracy of time alignment between them with the same number of nodes. Because transparent clocks record the residency time of a packet, any error in timestamp location, frequency offset, or drift will have a negative impact on their performance.

Even with these techniques, achieving highly accurate results with IEEE 1588 requires very careful planning and implementation.

5.3.3.3 Deployment Scenarios

In a CMTS Core + RPD system, the synchronization performance of the RPD becomes the key element to the overall DTP performance. Although a CMTS Core can participate as a 1588 GM or BC, the RPD may receive another and possibly better clock source within the network.

Some deployment examples are shown in Figure 11, Figure 12, Figure 13, and Figure 14.

5.3.3.3.1 Scenario 1

Figure 11 shows a deployment with these elements: CMTS Core is a 1588 OC Grandmaster, the RPD is a 1588 OC slave, and there are an indefinite number of non-participant nodes in between. The non-participant nodes are shown in white.

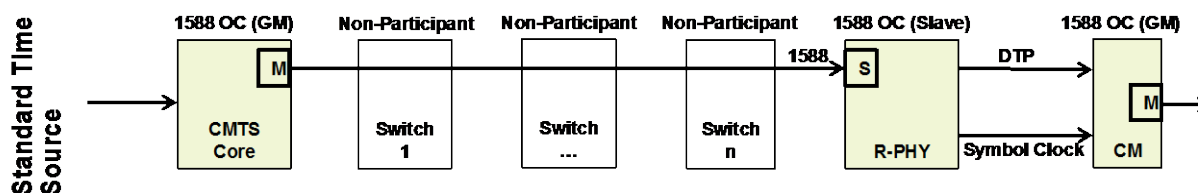

Figure 11 - Network Deployment Example 1

5.3.3.3.2 Scenario 2

Figure 12 shows a deployment with these elements: CMTS Core is a 1588 BC, the RPD is a 1588 OC slave, there are an indefinite number of BC nodes in between, and all nodes are Synchronous Ethernet capable.

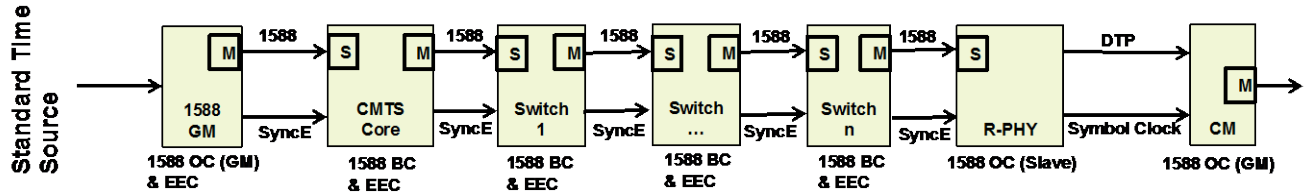

Figure 12 - Network Deployment Example 2

5.3.3.3.3 Scenario 3

Figure 13 shows a deployment with these elements: External Node is a 1588 OC Grandmaster, the RPD is a 1588 OC slave, the CMTS Core is a 1588 OC slave, and there are an indefinite (and mixed) number of node types in between. The non-participant nodes are shown in white.

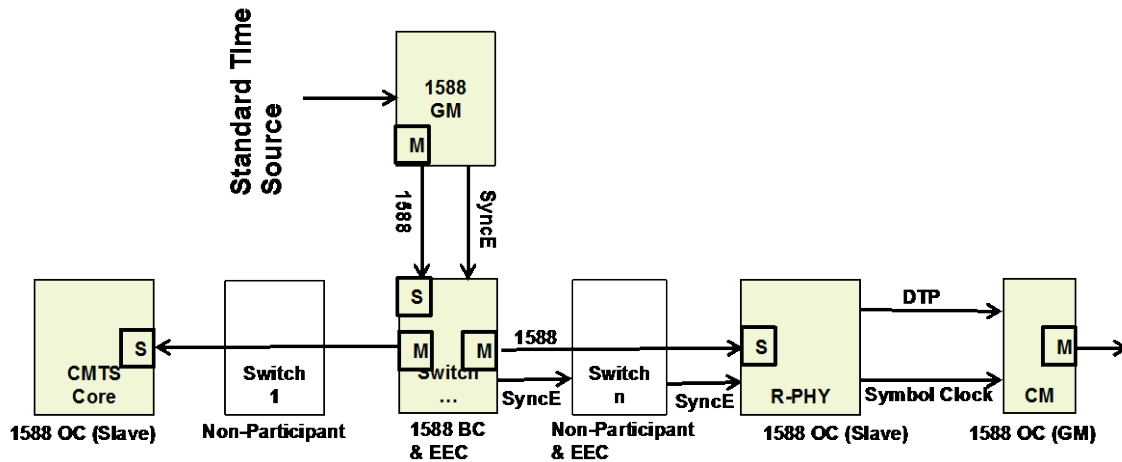

Figure 13 - Network Deployment Example 3

5.3.3.3.4 Scenario 4

In the example shown in Figure 14, the RPD synchronizes to a 1588 GM while the Node_Master is implemented for DOCSIS operation between the CMTS Core and the RPD. The External Node is a 1588 OC grandmaster, the RPD is a 1588 BC, and the CMTS Core is a 1588 OC slave. The physical clock of CMTS Core may be a different 1588 clock domain.

5.5.3.2 NDR

The Remote PHY narrowband digital return (NDR) refers to the digitizing of an analog portion of the upstream spectrum at the RPD, sending the digital samples as payload in upstream external PHY interface (UEPI) packets to the CCAP-Core, and then re-creating the original analog stream at the headend.

Since the headend plays out the digital samples at fixed rate, the rate of samples received from the RPD needs to match the CCAP-Core rate such that the FIFO buffers in the CCAP-Cores do not overflow or underrun. For this reason, the CCAP-Core and the RPD **MUST** remain frequency locked.

6 SYSTEM REQUIREMENTS

The requirements in this section are independent of the synchronization methods or operation modes described in Section 5.

6.1 DOCSIS Timing Requirements

6.1.1 RPD Master Clock Frequency Accuracy for DOCSIS

The 10.24 MHz RPD master clock MUST meet the frequency accuracy requirement specified in Section 6.3.5.2 of [DRFI], over a temperature range of 0 to 40 (TBD) degrees C and for up to ten (TBD) years from date of manufacture.

6.1.2 RPD Master Clock Jitter

The 10.24 MHz RPD master clock MUST meet the double sideband phase noise requirements over the specified frequency ranges defined in CMTS or EQAM Master Clock Jitter for Synchronous Operation, Section 6.3.5.3 of [DRFI], and DTI Client Test Port Clock, Section 7.2.7 of [DTI]. The requirements are summarized in Table 1.

Table 1 - RPD 10.24 MHz Master Clock Double Sideband Phase Noise Requirements

	Double Sideband Phase Noise Requirements	Jitter
10 Hz to 100 Hz	<-53 dBc	<0.035 ns RMS
100 Hz to 1 kHz	<-61 dBc	<0.014 ns RMS
1 kHz to 10 kHz	<-53 dBc	<0.035 ns RMS
10 kHz to 5.12 MHz	<-53 dBc	<0.035 ns RMS

6.1.2.1 RPD Master Clock Frequency Drift

The frequency of the RPD master clock MUST meet the drift requirement specified in CMTS or EQAM Master Clock Jitter for Asynchronous Operation, Section 6.3.5.2 of [DRFI].

6.1.2.2 RPD Clock Generation

Section 6.1.3 contains the RPD requirements for locking the downstream symbol clock to the master clock.

6.1.2.3 RPD Clock Generation for DOCSIS 3.0

The RPD MUST lock the downstream symbol clock to the RPD master clock using the M/N divisor specified in CMTS Clock Generation, Section 6.3.6.1 of [DRFI].

6.1.2.4 Downstream Symbol Rate

See Downstream Symbol Rate, Section 6.3.6.3 of [DRFI].

6.1.2.5 Downstream Symbol Clock Jitter for Synchronous Operation

See Downstream Symbol Rate for Downstream Symbol Clock Jitter for Synchronous Operation, Section 6.3.7 of [DRFI].

6.1.2.6 Downstream Symbol Clock Drift for Synchronous Operation

See Downstream Symbol Clock Drift for Synchronous Operation, Section 6.3.8 of [DRFI].

6.1.2.7 Timestamp Jitter

The DOCSIS timestamp jitter at RPD MUST meet the timestamp jitter requirement specified in Section 6.3.9, the Timestamp Jitter section of [DRFI], that is, be less than 500 ns peak-to-peak at the output of the downstream

transmission convergence sublayer. This jitter is relative to an ideal downstream transmission convergence sublayer that transfers the MPEG packet data to the downstream physical media dependent sublayer with a perfectly continuous and smooth clock at the MPEG packet data rate. Downstream physical media dependent sublayer processing **MUST NOT** be considered in timestamp generation and transfer to the downstream physical media dependent sublayer.

Thus, any two timestamps $N1$ and $N2$ ($N2 > N1$) which were transferred to the downstream physical media dependent sublayer at times $T1$ and $T2$ respectively **MUST** satisfy the following relationship:

$$|((N2 - N1))/f_{RPD} - (T2 - T1)| < 500 \times 10^{-9}$$

In the equation, the value of $(N2-N1)$ is assumed to account for the effect of rollover of the timebase counter, and $T1$ and $T2$ represent time measured in seconds. f_{RPD} is the actual frequency of the RPD master timebase and may include a fixed frequency offset from the nominal frequency of 10.24 MHz. This frequency offset is bounded by a requirement stated farther below in this section.

The jitter includes inaccuracy in timestamp value and the jitter in all clocks. The 500 ns allocated for jitter at the downstream transmission convergence sublayer output **MUST** be reduced by any jitter that is introduced by the downstream physical media dependent sublayer.

NOTE: Jitter is the error (i.e., measured) relative to the RPD local clock.

6.1.3 RPD Clock Generation for DOCSIS 3.1

This section specifies the timing and frequency synchronization requirements for DOCSIS 3.1 RPD transmitters.

The purpose of this section is to ensure that the RPD transmitter can provide proper timing and frequency references for DOCSIS 3.1 downstream orthogonal frequency division multiplexing (OFDM) operation.

The RPD downstream OFDM symbol and subcarrier frequency and timing relationship is defined in Section 7.3.3, the Subcarrier Clocking section of [PHYv3.1].

6.1.3.1 Downstream Sampling Rate

The RPD **MUST** lock the 204.8 MHz downstream OFDM Clock to the 10.24 MHz RPD Master Clock specified in Section 7.5.3.1, the Downstream Sampling Rate section of [PHYv3.1].

6.1.3.2 Downstream OFDM Symbol Clock Jitter

The RPD **MUST** adhere to the following double sideband phase noise requirements for the downstream OFDM symbol clock over the specified frequency ranges specified in Section 7.5.3.3, the Downstream OFDM Symbol Clock Jitter section of [PHYv3.1].

6.2 MPEG-TS Video

The system timing clock (STC) at the RPD **MUST** meet the frequency accuracy requirement ($\leq \pm 30$ PPM) and the drift requirement (≤ 10 PPM/hour) specified by [ISO 13818-1].

6.3 Video OOB

This section specifies the timing and frequency synchronization requirements for the video OOB frequency.

6.3.1 OOB 55-1

The RPD master clock **MUST** meet the frequency accuracy and stability requirements ($\leq \pm 100$ PPM) specified by [SCTE 55-1].

6.3.2 OOB 55-2

The RPD master clock **MUST** meet the frequency accuracy and stability requirements ($\leq \pm 50$ PPM) specified by [SCTE 55-2].

7 R-DTI IMPLEMENTATION SPECIFIC REQUIREMENTS

7.1 Protocol Support

CCAP-Core MUST support PTP messages over the following encapsulations defined in [IEEE 1588]:

- PTP over Ethernet/IEEE 802.3
- PTP over UDP over IPv4
- PTP over UDP over IPv6

RPD MUST support PTP messages over the following encapsulations defined in [IEEE 1588]:

- PTP over Ethernet/IEEE802.3
- PTP over UDP over IPv4
- PTP over UDP over IPv6

CCAP-Core MUST support the unicast model defined in [IEEE 1588].

RPD MUST support the unicast model defined in [IEEE 1588].

7.2 DOCSIS Timing Requirements

The RPD MUST support Node_Slave mode:

- RPD MUST support 1588 OC slave.
- RPD MUST meet all requirements specified in Section 6.1 and subsections thereof.
- RPD MUST meet time/phase synchronization accuracy of ± 1 ms in reference to the 1588 GM.
- RPD MUST inject the DOCSIS timestamp derived from the 1588 domain into the DOCSIS downstream path.
- RPD MUST use the DOCSIS timestamp derived from the 1588 domain to receive packets on an upstream receiver interface.

The CMTS Core MUST support Node_Slave mode:

- CMTS Core MUST support 1588 OC grandmaster.
- When CMTS Core operates as 1588 OC grandmaster, CMTS Core clock MUST meet the frequency accuracy and stability requirements specified in DRFI Output Electrical, Section 6.3.5 of [DRFI].
- CMTS Core MUST support 1588 OC slave.
- When CMTS Core operates as 1588 slave, CMTS Core MUST meet the time/phase synchronization accuracy of ± 1 ms in reference to the 1588 GM.
- CMTS Core MAY support 1588 BC.

The RPD MUST support Node_Master mode:

- RPD MUST support 1588 OC grandmaster.
- RPD MAY support 1588 BC.
- RPD MUST meet all requirements specified in Section 6.1 and subsections thereof.
- RPD MUST inject the local timestamp into the DOCSIS downstream path.

- RPD MUST use the same local DOCSIS timestamp to receive packets on an upstream receiver interface.

CMTS Core SHOULD support Node_Master mode. When CMTS Core operates in Node_Master mode:

- CMTS Core MUST support 1588 OC slaves to multiple 1588 clock domains.
- CMTS Core MUST generate MAPs based on the DOCSIS timestamps of the individual 1588 clock domains which are owned by individual RPDs.
- Time/phase synchronization between the RPD and the CMTS Core MUST be within ± 1 msec.

7.3 Precision Timing Services

The RPD and the CCAP-Core MUST support the following timing requirements:

- RPD MUST support DTP.
- RPD MUST support 1588 OC slave.
- RPD SHOULD support Synchronous Ethernet.
- RPD MAY support 1588 BC.
- CCAP-Core MAY support 1588 OC grandmaster.
- CCAP-Core MAY support Synchronous Ethernet.
- CCAP-Core MAY support 1588 BC.

7.3.1 Frequency Synchronization

The frequency synchronization performance of R-DTI is characterized by the frequency accuracy and can be categorized as shown in Table 2.

Table 2 - R-DTI Frequency Synchronization Performance

	Level I System	Level II System	Level III System	Level IV System	Level V System
f-rdti	± 5 PPB	± 16 PPB	± 50 PPB	± 100 PPB	± 250 PPB

7.3.2 Phase/Time Synchronization

The phase/time synchronization performance of R-DTI is characterized by the timing error between the standard time source and RPD, and can be categorized as shown in Table 3.

Table 3 - R-DTI Phase Synchronization Performance

	Level I System	Level II System	Level III System	Level IV System	Level V System
T-rdti-error	± 20 ns	± 40 ns	± 100 ns	± 200 ns	± 500 ns

7.4 NDF and NDR

The RPD and the CCAP-Core MUST support the following NDF and NDR requirements:

- CCAP-Core MUST support [IEEE 1588] OC grandmaster.
- CCAP-Core Master Clock MUST meet the frequency accuracy and stability spec defined in the DRFI Output Electrical section of [DRFI].
- RPD MUST support [IEEE 1588] OC slave.

- RPD MUST meet all the requirements specified in section 6 and subsections thereof.
- RPD MAY support Synchronous Ethernet.
- The MTIE (Maximum Time Interval Error) of the RPD clock is a reference to the CCAP-Core clock. The MTIE MUST be less than 1 ms in any given observation interval.

Appendix I RPD and DOCSIS System Performance

I.1 Introduction

Compared to an I-CMTS system, inserting a CIN between the CCAP-Core and the RPD increases the round-trip time of the DOCSIS system, and may impact system performance.

I.2 Round-Trip Time and Performance

Broadly speaking, round-trip time is the time from a CM's request to the time the CM transmits the data that corresponds to that request. The more quickly all this happens, the sooner the CM can transmit another request (for example, a piggyback request), thereby transmitting more data, etc.

Round-trip time limits the performance of a single modem by limiting the number of grants the modem can receive in a given time. For instance, if the system round-trip time is 10 ms, it is not possible for a modem to receive more than 100 grants per second. If every grant were the size of the modem's allowed maximum burst size (as configured by, e.g., Maximum Concatenated Burst, [RF1v2.0]), an upper bound on the modem's performance could be found by the following simple calculation:

$$\text{max throughput (bits/sec)} = \text{max burst (bits)} \times 1 / [\text{round trip time (sec)}]$$

In practice, due to the need to share bandwidth among many users and services, the maximum burst size needs to be limited to reasonable values, and the CCAP-Core generally cannot grant the maximum burst size in every grant, even if a modem requests it.

A longer round-trip time also increases the access latency seen by a single modem, that is to say, the time it takes for a modem to gain access to the upstream to begin transmission of new data after an idle period. Conversely, if reducing round-trip time enables higher throughput to be achieved or speeds the opening of the TCP window, the modem's transactions (e.g., download of an FTP file or HTTP web page) may be completed more quickly (assuming plant bandwidth is available to use). These factors may in turn affect the overall bandwidth efficiency of the system.

In DOCSIS 3.0 mode, the CM is able to send more requests before the grants. This reduces the round-trip time impact to the performance.

I.3 Elements of Round-Trip Time

It is convenient to begin measurement of round-trip time at the instant when a modem begins transmission of a request. Round-trip time can then be measured as the time from this initial request to the instant when the modem begins transmission of its next request. These events can be easily captured on a network sniffer.

The elements of round-trip time may be categorized as follows:

- *Upstream propagation delay*: time occupied by plant delays in the upstream direction.
- *Upstream reception and request parsing time*: time from the start of burst arrival at the RPD until the reception and parsing of the request to MAC-layer is complete. This includes the upstream PHY processing time; encapsulation of the request into a UEPI packet; queuing and transmission of the UEPI packet at the egress of the RPD; delay and jitter of the CIN; queuing, and processing delays inside the CMTS Core.
- *Scheduler queuing and processing delay*: time from arrival of the request at the scheduler until completion of the MAP message containing a grant for the request. If the request arrives just after the scheduler has finished creating a MAP, the request is delayed by the time interval until the next MAP. On the other hand, if the request arrives just before the scheduler finishes creating a MAP, the request may see nearly zero delay. In general, the actual queuing delay is a random variable between zero and the maximum MAP interval.

Under some lab conditions involving only one or a few CMs, this delay may appear to be constant, but this cannot generally be assumed in a real system. Some scheduler implementations may vary the MAP interval to optimize this delay. The time required for the scheduler to make scheduling decisions and actually create the MAP message is also included here. This factor is implementation-dependent.

- *MAP delivery time (to the RPD DOCSIS PHY layer)*: The time from the completion of the MAP message creation, to delivery of the MAP to the PHY layer. This includes any time consumed by the CMTS Core's MAC function; encapsulation of the MAP into a DEPI packet; queuing and transmission of the DEPI packet at the egress of the CMTS Core; delay and jitter of the CIN; queuing and processing delays inside the RPD; and any delay in inserting the MAP into the MPEG-encapsulated DOCSIS stream (e.g., due to the need to wait for a previous packet to complete transmission).
- *Downstream physical-layer delays*: This includes the latency of the downstream modulator, downstream interleaver delay, and physical propagation delay between the RPD and the CM.
- *CM MAP processing time*: The time from arrival of the first bit of the MAP at the CM, until the MAP becomes effective. The minimum value is specified in the Relative Processing Delay section of [RFIV2.0]. It accounts for all internal CM processing delays.
- *Time until grant*: If the first grant in the MAP is not available to this CM, the CM's actual transmission will be "delayed" until the actual time of the grant.
- *Margin*: In practice, the CMTS Core cannot precisely control all delays to guarantee that MAPs arrive at the modem at exactly the right instant. Thus, the CMTS Core needs to add margin to account for worst-case propagation delays to the farthest modems, variations in MAP creation time, and CIN delays.

Table 4 lists sample values for the round-trip time components described above. These values are given ONLY by way of example and should not be interpreted as typical values applying to any particular system.

Table 4 - Sample Values for the Round-Trip Time Components

Delay Source	Subtotal	Total	Remarks
Upstream propagation time		800	
<i>Physical HFC plant delay</i>	800		Approx. 100 miles
Upstream reception/parsing time		852 + CIN _{us}	
<i>Upstream PHY processing time</i>	369		Time for 1 FEC block (236,200) at 5.12 Mbps
UEPI packetization at RPD	383		
RPD to CMTS Core CIN Delay	varies		
Upstream MAC processing time	100		
Scheduler queuing and processing	1000	1000	
MAP delivery to PHY layer		1338 + CIN _{ds}	
<i>DEPI packetization at Core</i>	383		For MPT mode, transmit time of 7 MPEG packets
<i>CMTS Core to RPD CIN Delay</i>	varies		
<i>RPD latency</i>	500		Per [R-PHY] specification
<i>Queuing behind max-length packet MPEG encaps</i>	455		Packet size of 1518 bytes (64-QAM)
<i>Downstream transmission line</i>		1841	
<i>MAP duration on wire</i>	61		200B MAP at 64-QAM
<i>Downstream FEC/interleaver delay</i>	980		(I, J) = (32, 4) at 64-QAM
<i>Downstream propagation limit</i>	800		Approx. 100 miles
MAP advance margin		1500	Includes 1 ms budget for synchronization error
CM processing time		200	TDMA, no byte interleaving
		7531 + (CIN _{us} + CIN _{ds})	

In Table 4, factors shown in italics need to be considered in the MAP advance calculation.

Appendix II Acknowledgements

On behalf of the cable industry and our member companies, CableLabs would like to thank the following individuals for their contributions to the development of this specification:

Contributor	Company Affiliation
John T. Chapman	Cisco
Hang Jin	Cisco
Pawel Sowinski	Cisco
Yi Tang	Cisco

On behalf of the cable industry and our member companies, CableLabs would like to thank the following individuals for their contributions to the development of the technology and participation in the Remote PHY Working Group.

Contributor	Company Affiliation	Contributor	Company Affiliation
Bill Powell	Alcatel-Lucent	Nagesh Nandiraju	Comcast
Brian Kurtz	Altera	Saifur Rahman	Comcast
Carlton Lane	Analog	Jorge Salinger	Comcast
Linda Mazaheri	Analog	Joe Solomon	Comcast
Tom Ferreira	Arris	Douglas Will	Comcast
Steve Foley	Arris	Jeff Ford	Complex IQ
Anand Goenka	Arris	Al Garrett	Complex IQ
Jeff Howe	Arris	Ony Anglade	Cox Communications
Hari Nair	Arris	Mike Cooper	Cox Communications
Andrew Chagnon	Broadcom	Samir Parikh	Gainspeed Networks
Victor Hou	Broadcom	João Campos	Get
Niki Pantelias	Broadcom	Even Kristoffersen	Get
David Pullen	Broadcom	Adi Bonen	Harmonic
Stuart Hoggan	CableLabs	Mike Patrick	Harmonic
Volker Leisse	CableLabs	Jim Chen	Huawei
Karthik Sundaresan	CableLabs	Hesham ElBakoury	Huawei
Nikhil Tayal	CableLabs	Karl Moerder	Huawei
Jun Tian	CableLabs	Jack Moran	Huawei
Andrew Sundelin	CableLabs Consultant	Guangsheng Wu	Huawei
Naor Goldman	Capacicom	Phil Oakley	LGI
Dave Fox	Casa Systems	Stan Bochenek	Maxim Integrated
Maike Geng	Casa Systems	Ajay Kuckreja	Maxim Integrated
David Claussen	Charter	Len Dauphinee	MaxLinear
Nobo Akiya	Cisco	David Huang	MaxLinear
Alon Bernstein	Cisco	Louis Park	MaxLinear
Brian Bresnahan	Cisco	Sridhar Ramesh	MaxLinear
John T. Chapman	Cisco	Patrick Tierney	MaxLinear
Hang Jin	Cisco	Scott Walley	MaxLinear
Tong Liu	Cisco	Rei Brockett	Pace/Aurora

Contributor	Company Affiliation	Contributor	Company Affiliation
Carlos Pignataro	Cisco	Nasir Ansari	Rogers
Sangeeta Ramakrishnan	Cisco	George Hart	Rogers
John Ritchie	Cisco	Kevin Kwasny	Shaw
Pawel Sowinski	Cisco	Lee Johnson	ST Micro
Don Strausberger	Cisco	Paul Brooks	Time Warner Cable
Yi Tang	Cisco	Kirk Erichsen	Time Warner Cable
Bill Wall	Cisco	Colin Howlett	Vecima
Gerry White	Cisco	Douglas Johnson	Vecima
Philippe Perron	Cogeco	Faten Hijazi	Xilinx
John Bevilacqua	Comcast	Alex Luccisano	Xilinx

Additionally, CableLabs would like to thank the DCA MSO team for their continued support in driving the specification development and the decision-making process.

Karthik Sundaresan, CableLabs
