

Superseded

Cable Data Services DOCSIS® Provisioning of EPON Specifications

DPoE™ Physical Layer Specification

DPoE-SP-PHYv1.0-I01-110225

ISSUED

Notice

This DPoE specification is the result of a cooperative effort undertaken by certain member companies of Cable Television Laboratories, Inc. for the benefit of the cable industry and its customers. This document may contain references to other documents not owned or controlled by CableLabs. Use and understanding of this document may require access to such other documents. Designing, manufacturing, distributing, using, selling, or servicing products, or providing services, based on this document may require intellectual property licenses from third parties for technology referenced in this document.

Copied and Distributed by CableLabs under License.

Superseded

Document Status Sheet

Document Control Number:	DPoE-SP-PHYv1.0-I01-110225			
Document Title:	DPoE™ Physical Layer Specification			
Revision History:	I01 - Released 02/25/11			
Date:	February 25, 2011			
Status:	Work in Progress	Draft	Issued	Closed
Distribution Restrictions:	Author Only	CL/Member	CL/Member/Vendor	Public

Key to Document Status Codes

- Work in Progress** An incomplete document, designed to guide discussion and generate feedback that may include several alternative requirements for consideration.
- Draft** A document in specification format considered largely complete, but lacking review by Members and vendors. Drafts are susceptible to substantial change during the review process.
- Issued** A stable document, which has undergone rigorous member and vendor review and is suitable for product design and development, cross-vendor interoperability, and for certification testing.
- Closed** A static document, reviewed, tested, validated, and closed to further engineering change requests to the specification through CableLabs.

Trademarks

Advanced Digital Cable™, CableCARD™, CableHome®, CableLabs®, CableNET®, CableOffice™, CablePC™, DCAS™, DOCSIS®, DPoE™, EBIF™, eDOCSIS™, EuroDOCSIS™, EuroPacketCable™, Go2BroadbandSM, M-Card™, M-CMTS™, OCAP™, OpenCable™, PacketCable™, PCMM™, and tru2way® are marks of Cable Television Laboratories, Inc. All other marks are the property of their respective owners.

Superseded

1	INTRODUCTION	1
1.1	DPoE Technology Introduction.....	1
1.2	Scope.....	2
1.3	Goals.....	2
1.4	Requirements.....	2
1.5	Organization of Specifications.....	3
1.6	DPoE Specifications.....	3
1.7	Reference Architecture.....	4
1.8	DPoE Interfaces and Reference Points.....	5
2	REFERENCES	8
2.1	Normative References.....	8
2.2	Informative References.....	8
2.3	Reference Acquisition.....	9
3	TERMS AND DEFINITIONS	11
3.1	DPoE Elements.....	11
3.2	Other Terms.....	12
4	ABBREVIATIONS AND ACRONYMS	13
5	EPON PHY	14
5.1	DPoE Additional PHY Requirements.....	14
5.1.1	<i>Forward Error Correction</i>	14
5.1.2	<i>[1G] FEC</i>	14
5.1.3	<i>[10G] FEC</i>	14
5.2	Raman Interference Mitigation.....	15
5.3	Optical Monitoring.....	15
5.4	DPoE ONU Optical Power Control.....	16
6	DPOE ONU UNI: "S" INTERFACE	17
6.1	Physical Interfaces.....	17
6.2	Logical Interfaces.....	17
APPENDIX I	ACKNOWLEDGMENTS	18

Superseded

Figure 1 - DPoE Reference Architecture.....5
Figure 2 - DPoE Interfaces and Reference Points6
Figure 3 - DPoE Elements11
Figure 4 - Interference Spectra Without and With Raman Mitigation15
Figure 5 - IDLE Pattern Replacement Function15

Tables

Table 1 - DPoE Specifications.....3
Table 2 - DPoE Interface and Reference Point Descriptions6

1 INTRODUCTION **Superseded**

Comcast Corporation, Time Warner Cable, and Bright House Networks collaborated to develop the interoperability requirements to support business services products using Ethernet Passive Optical Network (EPON) as an access technology.

DOCSIS Provisioning of EPON (DPoE) is a joint effort of operators, vendors, and suppliers to support EPON technology using existing DOCSIS-based back office systems and processes.

Ethernet PON or EPON is an [802.3] standard for a passive optical network (PON). A PON is a specific type of multi-access optical network. A multi-access optical network is an optical fiber based network technology that permits more than two network elements to transmit and receive on the same fiber. Appendix I in [DPoE-SP-ARCHv1.0] has a more detailed explanation of multi-access optical networks.

This version of the DPoE specifications is focused on DOCSIS-based provisioning and operations of Internet Protocol (IP) using DOCSIS High Speed Data (HSD), or IP(HSD) for short, and Metro Ethernet Forum (MEF) services. DPoE Networks offer IP(HSD) services functionally equivalent to DOCSIS networks, where the DPoE System acts like a DOCSIS CMTS and the DPoE System and DPoE Optical Network Unit (ONU) to appear to act like a DOCSIS CM.

1.1 DPoE Technology Introduction

DPoE technology was established with the following common requirements already developed by operators. Each of the participant operators had previously selected 1G-EPON and 10G-EPON as the appropriate technology for one or more applications. EPON is a widely-deployed technology with a sufficient and large supply of vendors offering a variety of products for each component of the access network. 10G-EPON technology is now becoming available and is backwards compatible with 1G-EPON. A 1G-EPON network can be incrementally upgraded to 10G-EPON, adding or replacing ONUs one at a time if required. 1G-EPON and 10G-EPON are compatible with [SCTE 174] (RFoG).

The EPON protocol [802.3ah] and the amendment for 10G-EPON [802.3av] support a centralized operator-based controller (OLT) architecture with low cost Layer 2 access devices (ONU). The basic service mapping architecture in EPON is to map Ethernet (or IP) frame header information (such as addresses, IP DiffServ Code Points, Ethernet Q tag, S-VLAN/C-VLAN ID, ISID, bridge address, or other marking) to a logical circuit called a Logical Link Identifier (LLID) in [802.3ah]. The service function is similar to that used in DOCSIS networks in many ways because it is based on a centralized scheduler and uses an LLID which functions like an SID, supports both unicast and broadcast, and has other similarities.

Existing [802.3ah] EPON systems do interoperate within the strict definitions of 1G-EPON. Experience with lab testing, field trials, and deployments has shown operators that 1G-EPON OLT and ONU systems typically only interoperate with a single port ONU. This is because [802.3ah] specifies the interfaces on the PON (the DPoE TU interface) but does not specify any of the other system interfaces. For example, an OLT from vendor A will register an ONU from vendor B, but it is not possible to construct a VLAN from the DPoE MN interface to an S interface. This is a well-recognized limitation of [802.3ah]. The challenge is that neither 1G-EPON nor 10G-EPON specify OAMP to forward traffic between NNI ports and the PON, or UNI ports and the PON. This is not different from other Ethernet standards. For example, if two Ethernet switches from two different vendors are connected, each switch must typically be configured independently. The challenge for EPON is that the remote device (the ONU) cannot be reached, and therefore cannot be configured. A solution to this problem must then be based on developing a common (standard) method of reaching the controller for the ONU, identifying the ONU capabilities, and providing that information to the OLT so that it can configure a working end to forwarding service (in both directions).

Superseded

Even if EPON had solved that provisioning challenge, there is no standard management interfaces for the ongoing operations and maintenance of the network, including fault management, performance management, security, etc. Operators already have fully working and scaled-out systems that solve these challenges for DOCSIS networks. One of the primary goals for DPoE specifications is to use the existing DOCSIS back office infrastructure to scale up EPON-based business services.

1.2 Scope

This specification identifies requirements for the EPON PHY for the adaptation or additions to DOCSIS specifications that are required to support DOCSIS Provisioning of EPON.

This specification:

- Specifies interoperable implementations for various DPoE vendors; and
- Specifies additional requirements for EPON PHY layer as used in cable networks which are outside the scope of [802.3] specifications.

1.3 Goals

Collectively, the operators started the DPoE specification development to accomplish the following objectives:

- Identify and document the common requirements for triple play services for business customers over EPON.
- Adapt DOCSIS-based back office provisioning and operations models to EPON. This is the core objective of DPoE specifications.
- Develop consensus on additional requirements above and beyond DOCSIS specifications to take advantage of the capabilities of EPON. These are focused in the area of Ethernet services and MEF integration.
- Continue to leverage the supply chain and economic benefits of a large base of suppliers and high-volume supply chain in optics, subsystems, and network systems based on a commodity EPON technology. Doing so requires adapting operator processes and networks to the EPON system rather than making any changes to the EPON systems.
- Positioning DPoE specifications to continue to leverage those same benefits for 10G-EPON.
- Work with the established EPON vendor community to assure that these strategies can be effective to mutually develop DPoE Networks, and to create a marketplace for success for multiple vendors to provide solutions for the variety of needs within the operator environment.

1.4 Requirements

Throughout this document, the words that are used to define the significance of particular requirements are capitalized. These words are:

"MUST"	This word means that the item is an absolute requirement of this specification.
"MUST NOT"	This phrase means that the item is an absolute prohibition of this specification.
"SHOULD"	This word means that there may exist valid reasons in particular circumstances to ignore this item, but the full implications should be understood and the case carefully weighed before choosing a different course.

Superseded

"SHOULD NOT" This phrase means that there may exist valid reasons in particular circumstances when the listed behavior is acceptable or even useful, but the full implications should be understood and the case carefully weighed before implementing any behavior described with this label.

"MAY" This word means that this item is truly optional. One vendor may choose to include the item because a particular marketplace requires it or because it enhances the product, for example; another vendor may omit the same item.

1.5 Organization of Specifications

The DPoE specifications are organized around existing DOCSIS specifications. The purpose of matching DPoE specification documents to existing CableLabs DOCSIS, IEEE, IETF, and MEF requirements is to facilitate the mapping of services from existing DOCSIS infrastructure to DPoE infrastructure, and to provide an organization that will be easy to maintain as related (referenced) standards, recommendations, or specifications undergo independent changes.

There are two types of documents in the DPoE specifications. The first includes informative and requirements documents called specifications that detail the specific requirements for products claiming compliance with the specifications. The DPoE specifications also include a new kind of document that does not fit into any of the above categories. The IP Network Elements (IP NE) Requirements [DPoE-SP-IPNEv1.0] are a set of common requirements for the management of IP network elements that operators have developed, which are above and beyond the requirements in DOCSIS specifications, but are nonetheless required in DOCSIS CMTS products today. These are not specifications because no new protocols or algorithms are provided. Most of the requirements in IP NE are existing requirements based on IEEE, IETF, or other network management standards.

The DPoE documents are detailed in Section 1.6 of this document and duplicated, for reference, in each of the DPoE specifications.

1.6 DPoE Specifications

This document is one in a series of eight (8) documents comprising the DPoE specifications. Collectively these documents represent the operators' requirements for EPON-based commercial services.

Table 1 - DPoE Specifications

Document	Document Title	Description
DPoE-SP-ARCHv1.0	DPoE Architecture Specification	DOCSIS Provisioning of EPON introduction, architecture, and narrative. Specifies fundamental architectural requirements (those that apply to more than one specification). Explains the purpose of each document below.
DPoE-SP-OAMv1.0	DPoE OAM Extensions Specification	Extensions beyond [802.3ah] and [802.3av] requirements.
DPoE-SP-PHYv1.0	DPoE Physical Layer Specification	Using the EPON PHY, the DPoE PHY specification makes mandatory some options within EPON and adds some additional requirements.

Superseded

Document	Document Title	Description
DPoE-SP-SECv1.0	DPoE Security and Certificate Specification	Specifications for support for DOCSIS network and system interfaces to provide transparent support of DOCSIS device authentication, code verification, and additional security for a DPoE implementation.
DPoE-SP-IPNEv1.0	DPoE IP Network Element Requirements	Best practices and operator requirements for IP network element management and operations. This document includes CMTS-like IP router requirements. This document recommends practices not currently covered by any existing DOCSIS specifications.
DPoE-SP-MULPIv1.0	DPoE MAC and Upper Layer Protocols Requirements	Specifications for support of a subset of DOCSIS 3.0 MULPI functionality with additional EPON requirements.
DPoE-SP-MEFv1.0	DPoE Metro Ethernet Forum Specification	Specifications for Metro Ethernet services added to DOCSIS static configuration provisioning model.
DPoE-SP-OSSIV1.0	DPoE Operations and Support System Interface Specification	Specifications for support of a subset of DOCSIS 3.0 OSSI functionality with additional EPON requirements.

1.7 Reference Architecture

The DPoE reference architecture identifies the elements that a DPoE Network minimally requires to illustrate and communicate the physical hardware and logical software interfaces between the functional subsystems of the DPoE architecture. The principal elements in the architecture are the DPoE System that resides in the operator network, and the DPoE ONU which may be an off the shelf EPON ONU, EPON SFP-ONU, or an EPON ONU with additional subsystems. The remaining elements in the architecture are existing servers and systems in the operator's network. All of the server elements have connectivity through an IP (TCP/IP) network. Transport of bearer traffic, and (in some cases) Layer 2 OAM signaling are available through either IP or Layer 2 Ethernet-based Network Interfaces.

Superseded

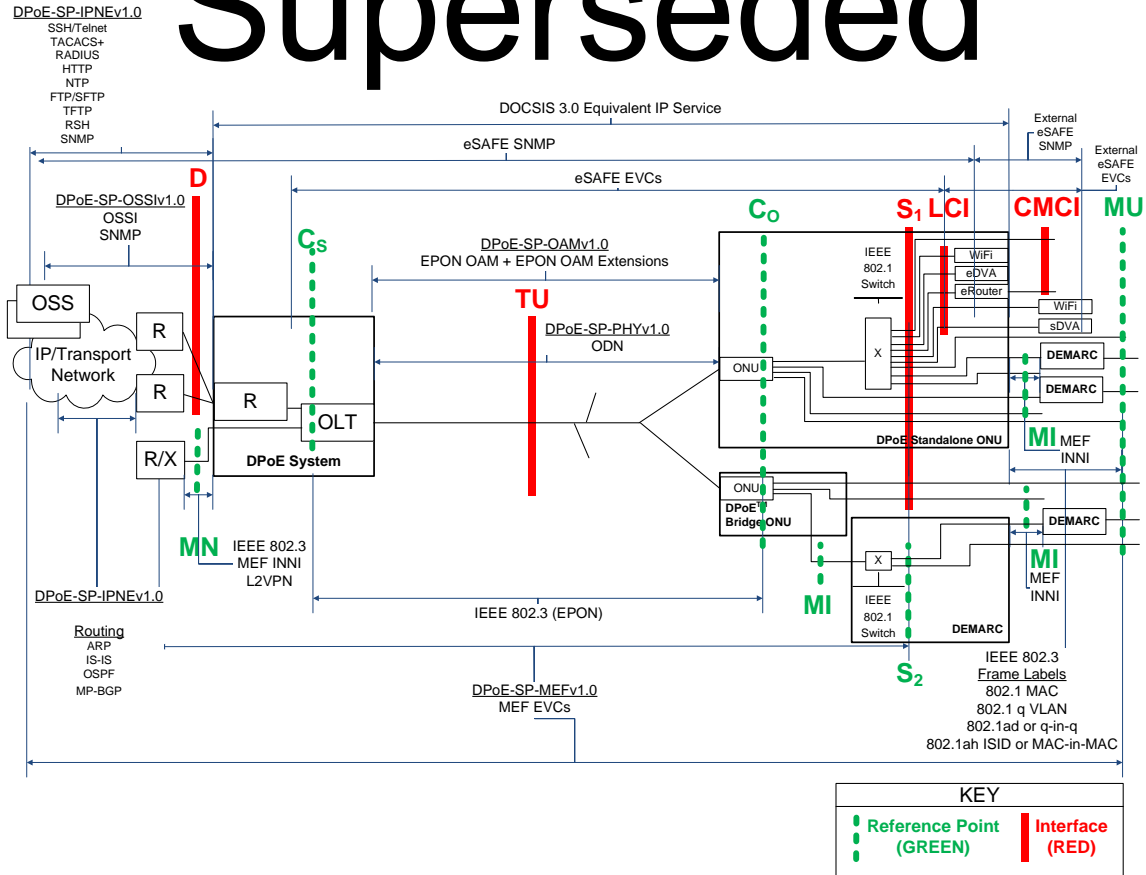

Figure 2 - DPoE Interfaces and Reference Points

Table 2 - DPoE Interface and Reference Point Descriptions

Interface or Reference Point	Interface or Reference Point Description				
MN	The MN interface is an [802.3] interface for Ethernet (or MEF or L2VPN emulated) services only. It serves the role of a MEF INNI or L2VPN NSI. It is an NNI for Metro Ethernet services only.				
D	The D interface is the DOCSIS IP NNI interface. It is an operator network facing interface, sometimes called a Network to Network Interface (NNI) or Network Systems Interface (NSI) in DOCSIS specifications. The D interface allows a DPoE System to communicate with an IP network. The D interface carries all IP management traffic including OSSI and IP NE traffic. The D interface carries all DOCSIS IP service traffic.				
TU	The TU interface is a short form of expressing the interface between the DPoE System and the DPoE ONU.				
C	The C reference point is used for explanation of traffic ingress to a DPoE classifier.				
	<table border="0"> <tr> <td>C₀</td> <td>The C₀ reference point is used for explanation of traffic ingress to a DPoE ONU upstream classifier.</td> </tr> <tr> <td>C_s</td> <td>The C_s reference point is used for explanation of traffic ingress to a DPoE System downstream classifier.</td> </tr> </table>	C ₀	The C ₀ reference point is used for explanation of traffic ingress to a DPoE ONU upstream classifier.	C _s	The C _s reference point is used for explanation of traffic ingress to a DPoE System downstream classifier.
C ₀	The C ₀ reference point is used for explanation of traffic ingress to a DPoE ONU upstream classifier.				
C _s	The C _s reference point is used for explanation of traffic ingress to a DPoE System downstream classifier.				

Superseded

Interface or Reference Point	Interface or Reference Point	Description
S		<p>The S interface is an IEEE 802 interface. The S interface may be an internal interface (such as [802.3] across a GMII SERDES or XGMII interface in an SFP-ONU, SFP+ONU or XFP-ONU) or it may be an external Ethernet interface.</p> <p>S₁ is an interface for a DPoE Standalone ONU. S₂ is a reference point used for explanation of services with the DPoE Bridge ONU.</p>
	S ₁	The S ₁ interfaces are the general case of all interfaces on a DPoE Standalone ONU. S ₁ interfaces may be CMCI, LCI, MI, or MU interfaces.
	S ₂	The S ₂ reference point is used for explanation of traffic ingress to and egress from interfaces on a DEMARC device in a DPoE System. Although there are no specifications or requirements for the S ₂ reference point, informative text refers to the S ₂ reference point to provide the full context for the use of a DPoE Bridge ONU in a DEMARC device providing Metro Ethernet services.
LCI		The Logical CPE Interface (LCI) interface is an eDOCSIS interface as defined in [eDOCSIS]. The eDOCSIS architecture is [802.1d] MAC based according to the DOCSIS 3.0 specifications; however, DOCSIS L2VPN clearly supports [802.1q] switching. In practice, therefore, the eDOCSIS interface consists of a DOCSIS classifier and [802.1] switch as illustrated. The function of a DOCSIS classifier is in part replaced by forwarding (tagging and encapsulation) in MEF and in part covered by classifiers in [DPoE-SP-MULPIv1.0].
CMCI		CMCI is the DPoE interface equivalent of the DOCSIS Cable Modem CPE Interface as defined in [CMCIv3.0]. This is the service interface for DOCSIS-based IP services.
MI		<p>MI is usually an S interface (or S reference point) that operates as a MEF INNI.</p> <p>A DPoE ONU that provides a MEF INNI has an MI interface.</p> <p>A DPoE ONU can have MU as an interface and an MI reference point on different S interfaces in a single DPoE ONU.</p> <p>The MI interface or reference point is an [802.3] interface (or reference point) between a DPoE ONU and a DEMARC device.</p>
MU		<p>MU is usually an S interface (or S reference point) that operates as a MEF UNI.</p> <p>A DPoE ONU that directly provides a MEF UNI (MU) interface has MU as an interface.</p> <p>A DPoE ONU can have MU as an interface and an MI reference point on different S interfaces in a single DPoE ONU.</p> <p>The MU interface or reference point is an [802.3] interface (or reference point) between a DPoE ONU or a DEMARC device and a customer's equipment.</p>

2 REFERENCE **Superseded**

2.1 Normative References

In order to claim compliance with this specification, it is necessary to conform to the following standards and other works as indicated, in addition to the other requirements of this specification. Notwithstanding, intellectual property rights may be required to use or implement such normative references. At the time of publication, the editions indicated were valid. All references are subject to revision, and users of this document are encouraged to investigate the possibility of applying the most recent editions of the documents listed below. References are either specific (identified by date of publication, edition number, version number, etc.) or non-specific. For a non-specific reference, the latest version applies.

- [10G] P802.3av amendment to IEEE 802.3-2008: Physical Layer Specifications and Management Parameters for 10 Gb/s Passive Optical Networks, released 11.2009.
- [1G] P802.3ah amendment to IEEE 802.3-2005: Media Access Control Parameters, Physical Layers, and Management Parameters for Subscriber Access Networks, now part of IEEE 802.3-2008.
- [802.1] Refers to entire suite of IEEE 802.1 standards unless otherwise specified.
- [802.1d] IEEE Std 802.1d-2004™, IEEE Standard for Local and Metropolitan Area Networks: Media Access Control (MAC) Bridges
- [802.1q] IEEE Std. 802.1q-2009, IEEE Standard for Local and Metropolitan Area Networks-Virtual Bridged Local Area Networks, January 2010.
- [802.3] IEEE 802.3-2008, Carrier Sense Multiple Access with Collision Detection (CSMA/CD) access method and Physical Layer specifications, released 2008.
- [802.3ah] IEEE 802.3ah™-2004: Amendment to IEEE 802.3™-2005: Media Access Control Parameters, Physical Layers, and Management Parameters for Subscriber Access Networks, now part of [802.3].
- [802.3av] IEEE 802.3AV-2009, IEEE Standard for Information technology-Telecommunications and information systems-Local and metropolitan area networks-Specific requirements, Part3 3: Carrier Sense Multiple Access with Collision Detection (CSMA/CD) Access Method and Physical Layer Specifications Amendment 1: Physical Layer Specifications and Management Parameters for 10Gb/s Passive Optical Networks.
- [DPoE-SP-OAMv1.0] DPoE-SP-OAMv1.0, DOCSIS Provisioning of EPON, OAM Extensions Specification, Cable Television Laboratories, Inc.
- [SFF-8472] SFF-8472 Specification for Diagnostic Monitoring Interface for Optical Transceivers, Revision 10.4, released January 2009.
- [SFP MSA] INF 8074i Rev 1.0, Small Form-factor Pluggable Multi-Source Agreement, released 12 May 2001.

2.2 Informative References

This specification uses the following informative references.

- [802.1ag] IEEE Std 802.1ag–2007™, IEEE Standard for Local and Metropolitan Area Networks – Virtual Bridged Local Area Networks Amendment 5: Connectivity Fault Management, December 2007.

Superseded

[802.3ag]	IEEE Std 802.3ag-2007™, IEEE Standard for Local and Metropolitan Area Networks-Virtual Bridged Local Area Networks-Amendment 5: Connectivity Fault Management, January 2007.
[CMCIv3.0]	Data-Over-Cable Service Interface Specifications, Cable Modem to Customer Premise Equipment Interface Specification, CM-SP-CMCIv3.0, Cable Television Laboratories, Inc.
[DOCSIS]	Refers to entire suite of DOCSIS 3.0 specifications unless otherwise specified.
[DPoE-SP-ARCHv1.0]	DPoE-SP-ARCHv1.0, DOCSIS Provisioning of EPON, DPoE Architecture Specification, Cable Television Laboratories, Inc.
[DPoE-SP-IPNEv1.0]	DPoE-SP-IPNEv1.0, DOCSIS Provisioning of EPON, IP Network Element Requirements, Cable Television Laboratories, Inc.
[DPoE-SP-MEFv1.0]	DOCSIS Provisioning of EPON, Metro Ethernet Forum Specification, DPoE-SP-MEFv1.0, Cable Television Laboratories, Inc.
[DPoE-SP-MULPIv1.0]	DPoE-SP-MULPIv1.0, DOCSIS Provisioning of EPON, MAC and Upper Layer Protocols Requirements, Cable Television Laboratories, Inc.
[DPoE-SP-OSSIV1.0]	DPoE-SP-OSSIV1.0, DOCSIS Provisioning of EPON, Operations and Support System Interface Specification, Cable Television Laboratories, Inc.
[DPoE-SP-SECv1.0]	DPoE-SP-SECv1.0, DOCSIS Provisioning of EPON, Security and Certificate Specification, Cable Television Laboratories, Inc.
[eDOCSIS]	Data-Over-Cable Service Interface Specifications, eDOCSIS Specification, CM-SP-eDOCSIS, Cable Television Laboratories, Inc.
[MULPIv3.0]	Data-Over-Cable Service Interface Specifications, MAC and Upper Layer Protocols Interface Specification, CM-SP-MULPIv3.0, Cable Television Laboratories, Inc.
[PHYv3.0]	Data-Over-Cable Service Interface Specifications, Physical Layer Specification, CM-SP-PHYv3.0, Cable Television Laboratories, Inc.
[RFC 2011]	IETF RFC 2011, SNMPv2 Management Information Base for the Internet Protocol using SMIv2, K. McCloghrie, November 1996.
[RFC 2863]	IETF RFC 2863, The Interfaces Group MIB, K. McCloghrie, F. Kastenholz, June 2000.
[RFC 3418]	IETF RFC 3418, Management Information Base (MIB) for the Simple Network Management Protocol (SNMP), R. Presuhn, Ed., June 2000.
[RFC 4188]	IETF RFC 4188, K. Norseth, Ed. and E. Bell, Ed., Definitions of Managed Objects for Bridges, September 2005.
[RFC 4293]	IETF RFC 4293, Management Information Base for the Internet Protocol (IP), S. Routhier, April 2006.
[SCTE 174]	SCTE 174 2010, Radio Frequency over Glass Fiber-to-the-Home Specification

2.3 Reference Acquisition

- Cable Television Laboratories, Inc., 858 Coal Creek Circle, Louisville, CO 80027; Phone +1-303-661-9100; Fax +1-303-661-9199; <http://www.cablelabs.com>
- Internet Engineering Task Force (IETF) Secretariat, 48377 Fremont Blvd., Suite 117, Fremont, California 94538, USA, Phone: +1-510-492-4080, Fax: +1-510-492-4001, <http://www.ietf.org>

Superseded

- Institute of Electrical and Electronics Engineers (IEEE), +1-800-422-6333 (USA and Canada); <http://www.ieee.org>
- Small Form Factor Committee (SFF), <http://www.sffcommittee.com>
- SCTE, Society of Cable Telecommunications Engineers Inc., 140 Philips Road, Exton, PA 19341
Phone: +1-800-542-5040, Fax: +1-610-363-5898, Internet: <http://www.scte.org/>

3 TERMS AND DEFINITIONS

Superseded

3.1 DPoE Elements

- DPoE Network** This term means the entire network described in Figure 3 from the D or MN interface to the LCI, S, MI, or MU interface (see Figure 2 for interface and reference points), depending on the service being described. In no case does the term DPoE Network ever include a DEMARC device.
- DPoE System** This term means all of the collected elements that provide the DPoE function within the operator's network facilities. This includes the EPON OLT function, DOCSIS service functions required for the D interface, Metro Ethernet service functions required for the MN interface, and IP NE element management, routing and forwarding functions specified in [DPoE-SP-IPNEv1.0]. The DPoE System is depicted in Figure 3.
- DPoE ONU** This term means a DPoE-capable ONU that complies with all of the DPoE specifications. There are two types of DPoE ONUs. These are the DPoE Standalone ONU and the DPoE Bridge ONU.
- DPoE Standalone ONU** This term means a DPoE ONU that is a standalone ONU capable of providing IP or Ethernet services directly to customer premise equipment or transport of traffic to an external DEMARC device.
- DPoE Bridge ONU** This term means a DPoE ONU that is capable of [802.1] forwarding but cannot do all of the encapsulation functions required to be a DPoE Standalone ONU. Examples include an SFP-ONU and some simple EPON chipset-only based ONUs.
- DEMARC** Short form of "Demarcation Device." This term means the device, owned and operated by the operator that provides the demarcation (sometimes called the UNI interface) to the customer. Some architectures describe this device as the CPE (as in DOCSIS, DSL, or Broadband Forum Models) or the NID (as in the MEF model).

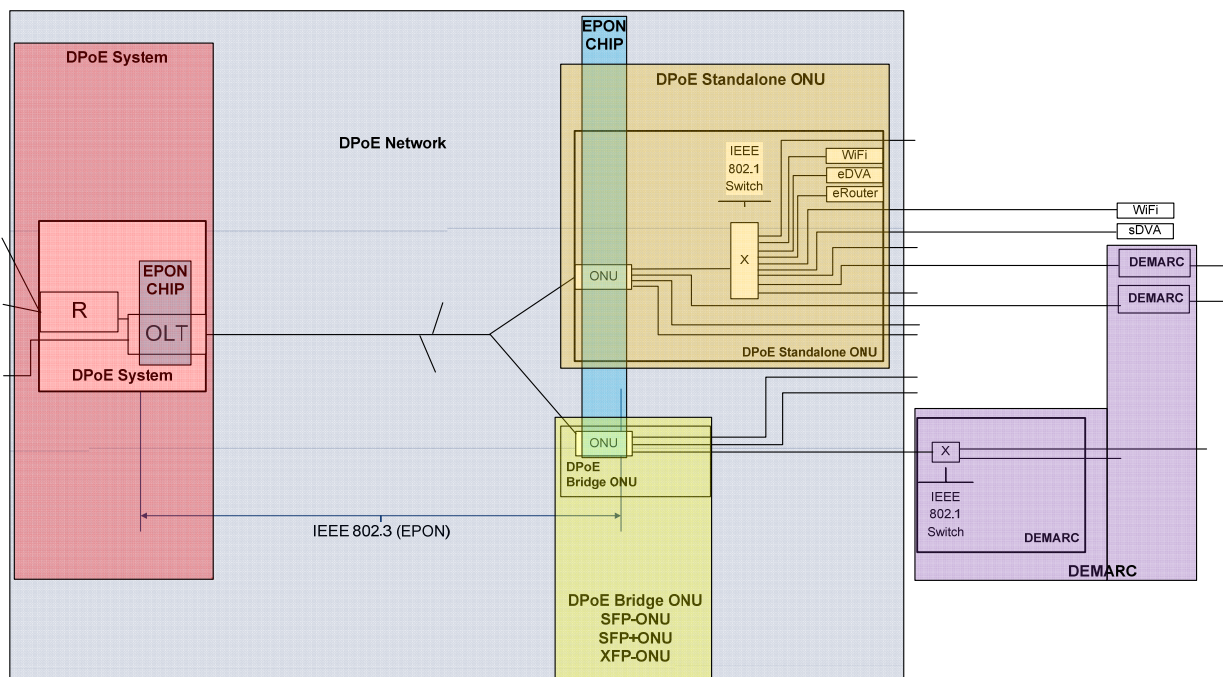

Figure 3 - DPoE Elements

3.2 Other Terms **Superseded**

1G-EPON	EPON as defined in [802.3ah]
10G-EPON	EPON as defined in [802.3ah] and amended in [802.3av]
Cable Modem CPE Interface	CMCI as defined in [MULPIv3.0]
Customer Premise Equipment (CPE)	Customer Premise Equipment as defined in [DOCSIS]
Ethernet Passive Optical Network (EPON)	Refers to both 1G-EPON and 10G-EPON collectively
EPON Operations and Maintenance Messaging (OAM)	EPON OAM messaging as defined in [802.3ah] and [DPoE-SP-OAMv1.0]; Ethernet OAM is not the same as EPON OAM; Ethernet OAM is [802.1ag]
Logical CPE Interface	LCI as defined in [eDOCSIS]
Network Interface Device (NID)	A DEMARC device in DPoE specifications

4 ABBREVIATIONS AND ACRONYMS

Superseded

This specification uses the following abbreviations:

BER	Bit error ratio
CMCI	Cable Modem CPE Interface
CoS	Class of Service
DEMARC	Demarcation Device
DoS	Denial of Service
DPoE	DOCSIS Provisioning and operations of EPON
eCM	embedded Cable Modem
eDVA	embedded Digital Voice Adapter
EPON	Ethernet Passive Optical Network
EVC	Ethernet Virtual Connection
FEC	Forward error correction
IP	Internet Protocol
L2VPN	Layer two virtual network
LCI	Logical CPE Interface
LLID	Logical Link IDentifier
MEF	Metro Ethernet Forum
ODN	Optical distribution network
OLT	Optical Line Termination
ONU	Optical Network Unit
OSC	Optical Splitter Combiner
PCS	Physical Coding Sublayer
PHY	Physical Layer
PMA	Physical Medium Attachment
PMD	Physical Media Dependent (Sublayer)
PON	Passive optical network
R	IP Router
SFP	Small Form-factor Pluggable
SFP+	Small Form-factor Pluggable Plus (+)
UNI	User Network Interface
X	IEEE Ethernet Switch (Generic)
XFP	X Form-factor Pluggable

5 EPON PHY Superseded

The specifications for the EPON PHY are in [802.3ah] and [802.3av]. [802.3] contains specifications for optical module wavelengths, receiver sensitivity, and other parameters defining the EPON physical layer used in DPoE networks. Details of wavelength planning, supported optical budgets, and split ratios for particular deployments are outside the scope of this specification.

5.1 DPoE Additional PHY Requirements

DPoE Systems MUST support all of the Physical Media Dependent (PMD) classes defined in [802.3] [1G], Clause 60 (1G-EPON), and Clause 75 (10G-EPON) [10G].

5.1.1 Forward Error Correction

The DPoE System MUST support the Forward Error Correction (FEC) methods defined in [802.3], with the additional capabilities as defined in this section. The DPoE ONU MUST also support the Forward Error Correction (FEC) methods defined in [802.3], with the additional capabilities defined in this section.

5.1.2 [1G] FEC

A DPoE System MUST support FEC as defined in [1G]. A DPoE ONU MUST support FEC as defined in [1G].

The DPoE System MUST support different FEC states (enabled / disabled) in the upstream and downstream directions. Correspondingly, the DPoE ONU MUST support different FEC states (enabled / disabled) in the upstream and downstream directions.

The DPoE System MUST support enabling FEC on a per logical link basis. The DPoE ONU MUST also support enabling FEC on a per logical link basis. FEC may be individually enabled for one or more of the logical links on the PON, may be enabled for all logical links on the PON, or may be disabled altogether, according to operator provisioning.

At the time of registration, the DPoE ONU MUST automatically detect the presence of FEC-encoded frames in the downstream, and set the initial state of FEC for the link to be registered in the upstream to match. The DPoE System MUST be able to enable or disable FEC encoding according to operator provisioning via OAM after the link has registered.

5.1.3 [10G] FEC

A DPoE System MUST support FEC as defined in [10G]. A DPoE ONU MUST support FEC as defined in [10G].

The DPoE System MUST support disabling of FEC for the entire PON so that it can be operated without FEC overhead if the optical budget allows. In the same way, the DPoE ONU MUST also support the disabling of FEC.

A 10G DPoE ONU MUST automatically detect the presence of an FEC encoded downstream, and set the initial state of its upstream FEC to match. The DPoE System MUST be able to enable FEC for the PON according to operator provisioning. Changing FEC at [10G] is a service-affecting action that requires DPoE ONUs to re-register after the change.

5.2 Raman Interference Mitigation **Superseded**

The DPoE System **MUST** provide means for reducing Raman interference of the EPON downstream with other optical wavelengths by replacing [802.3] IDLE time by randomized frames as defined in this section.

Standard 1 Gbit/s Ethernet transmission features transmission of an IDLE pattern (comprising an alternating sequences of 1s and 0s) when there is no subscriber data to be transmitted. The high frequency component of such a data pattern produces interference affecting other optical wavelengths. In the [802.3ah] based DPoE Network, the downstream optical channel transmitted at the central wavelength of 1490 nm (digital data) produces a power spike at the optical channel transmitted at the central wavelength of 1550 nm (RF video). The Raman mitigation technique reduces this interference by minimizing the power transmitted in the high frequency component, as shown in Figure 4 below.

The standard Ethernet IDLE is replaced by an Ethernet frame carrying a payload with a random pattern, spreading transmitted optical power over a wider spectrum, reducing the interference at specific other wavelengths.



Figure 4 - Interference Spectra Without and With Raman Mitigation

The DPoE System **MUST** always transmit actual network data in the downstream if such is available.

If the DPoE System detects a sufficiently long idle period on the NNI interface, with the size equal to a minimum Ethernet frame (64 bytes plus 8 bytes of preamble and 12 bytes of IPG), the DPoE System **MUST** replace this IDLE frame with an internally generated Ethernet frame with a random payload, as described above. This frame **MUST** be sent on a unicast LLID that is not connected to any DPoE ONU on the particular DPoE System TU (PON) interface, ensuring thus that no DPoE ONU can receive such a frame. The DPoE System **MUST** generate a payload for this frame such that it comprises of a sequence of uniformly distributed random values.

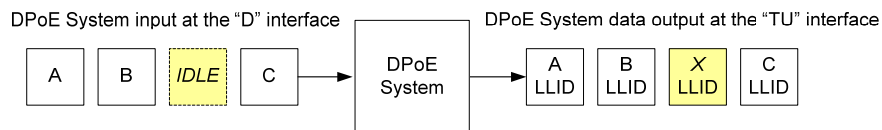

Figure 5 - IDLE Pattern Replacement Function

5.3 Optical Monitoring

A DPoE System **MUST** support all optical monitoring values as specified in [SFF-8472], including monitoring received optical power, transmit power, transmit bias current, internal voltage, and temperature. Similarly the DPoE ONU **MUST** support all optical monitoring values as specified in [SFF-8472], including monitoring received optical power, transmit power, transmit bias current, internal voltage, and temperature.

A DPoE System MUST be able to report received optical power on a per logical link basis, as well as reporting received optical power during the time of the PON upstream.

Superseded

5.4 DPoE ONU Optical Power Control

One possible failure mode for a DPoE ONU is for the laser driver to remain in the enabled state outside of the assigned transmission slot, continually generating light into the PON, interfering with transmissions of other DPoE ONUs in the upstream. The DPoE System MUST be able to isolate such failed DPoE ONUs from the PON by disabling their transmitter until the DPoE ONU can be replaced. The DPoE System disables a DPoE ONU laser by means of a specialized DPoE OAM message. A DPoE ONU MUST support an optical power disable command from the [DPoE-SP-OAMv1.0].

A DPoE ONU MUST be able to disconnect the power supply from the optical module under software control. A DPoE ONU MUST be able to separately control the power supplies to the transmit and receive paths of the optical module. A DPoE System MUST be able to send an OAM message to the DPoE ONU to signal optical power shutdown. If the DPoE System sends such a message, the DPoE ONU MUST turn off or disconnect the power to the optical module. Once the optical module is disconnected, the DPoE System cannot signal the DPoE ONU to turn on the power. Therefore, a DPoE ONU that implements such a feature MUST retain this setting when it is rebooted or power-cycled (in non-volatile storage). The DPoE ONU MAY remove this setting if it reset by means other than a software reboot or power-cycle (for example a RESET button or similar means).

DPoE Bridge ONU that complies with the [SFP MSA] SHOULD be able to disconnect the power supply from the optical module (within the SFP module) under software control. A DPoE Bridge ONU that complies with the [SFP MSA] SHOULD be able to separately control the power supplies to the transmit and receive paths of the optical module within the SFP module. These requirements apply to the optical module within the DPoE Bridge ONU and do not apply to the SFP module itself, because the transmit and received power pins for the SFP module supply power (in parallel) to both the optical and Layer 2 subsystems within the SFP ONU.

The procedure used to detect malfunctioning DPoE ONUs, and decide whether to disable them or not, is outside the scope of this specification. In general, network error statistics are used to detect any transmission problems, and malfunctioning DPoE ONUs are distinguished from working DPoE ONUs by disabling their lasers temporarily. Once the specific DPoE ONU has been identified as the source of the problem, it is permanently disabled using the DPoE OAM.

A DPoE System MUST provide the operator the capability to turn on or off such a rogue DPoE ONU detection function for each PON and for an entire DPoE System.

6 DPOE ONU UNI "S" INTERFACE

Superseded

The S interface in Figure 2 is the User to Network Interface (UNI). DPoE Systems support two types of S interfaces. These are either physical or logical interfaces. Although logical interfaces do not necessarily connect to the CPE, the transport of services to logical and physical interfaces is the same. Any S interface that is configured as a CMCI, MI, or MU interface is a Physical Interface.

6.1 Physical Interfaces

DPoE Standalone ONUs and DPoE Bridge ONUs that do not comply with the [SFP MSA] MUST support standard Ethernet interfaces for the S interfaces configured as (CMCI, MI, or MU) physical interfaces, as defined in [802.3].

A DPoE Bridge ONU that complies with the [SFP MSA] MUST support the standard SFP interface defined in the [SFP MSA]. A DPoE Bridge ONU that complies with the [SFP MSA] MUST also support the digital management interface defined in [SFF-8472].

6.2 Logical Interfaces

In addition to a physical interface, a DPoE ONU MAY have a logical Ethernet [802.3] interface. This interface could be used to provide an Ethernet transport across the PON from the DPoE System to a real physical interface within the DPoE ONU package. It could be a sub-interface to a switch or bridge group within the DPoE ONU, or a sub-interface on an [802.3] interface of a real Physical Interface as in Section 6.1 above.

Superseded

Appendix I Acknowledgments

On behalf of our industry, we would like to thank the following individuals for their contributions to the development of this specification.

Contributor	Company Affiliation
John Dickinson	Bright House Networks
Andrew Chagnon, Drew Davis, James Fletcher, Paul Gray	Broadcom
Mike Holmes	Broadway Networks
Curtis Knittle, Bob Lund, Glenn Russell	CableLabs
Shamim Akhtar, Doug Jones, Mehmet Toy	Comcast
Vladimir Bronstein, James Chen, Hesham ElBakoury	Hitachi Communication Technologies America
Victor Blake	Independent Consultant
Robert Harris, Karen Rice, Ashish Sardesai	Time Warner Cable
Marek Hajduczenia, Nevin Jones, Zang Meiyuan	ZTE

In addition to the above, we would like to thank the following individuals who provided subject matter expertise on one or more aspects of the project:

Contributor	Company Affiliation
Edwin Mallette	Bright House Networks
Andrew Dellow, Niki Pantelias, Ricki Li, Paul Runcy, Ed Boyd, Howard Abramson, Matt Hartling	Broadcom
Jianhui Zhou, Wen Li, Fulin Pan	Broadway Networks
Brian Hedstrom, Stuart Hoggan, Greg White, Karthik Sundaresan, Chris Donley	CableLabs
Jason Combs, Saif Rahman, Matt Scully, Bin Wen, Philip Chang, Rashid Siddiqui	Comcast
Dylan Ko, Simon Zhu, Guru Yeleswarapu, Jeff Stribling	Hitachi
Ron daSilva, Mike Kelsen, Shan Huang, Matt Cannon, Tushar Nakhre	Time Warner Cable
Stove Li Zhang, David Chen, Dick Chen	ZTE