

DOCSIS® Provisioning of EPON Specifications

DPoEv1.0

DPoE Physical Layer Specification

DPoE-SP-PHYv1.0-I05-140807

ISSUED

Notice

This DPoE™ specification is the result of a cooperative effort undertaken at the direction of Cable Television Laboratories, Inc. for the benefit of the cable industry and its customers. You may download, copy, distribute, and reference the documents herein only for the purpose of developing products or services in accordance with such documents, and educational use. Except as granted by CableLabs in a separate written license agreement, no license is granted to modify the documents herein (except via the Engineering Change process), or to use, copy, modify or distribute the documents for any other purpose.

This document may contain references to other documents not owned or controlled by CableLabs. Use and understanding of this document may require access to such other documents. Designing, manufacturing, distributing, using, selling, or servicing products, or providing services, based on this document may require intellectual property licenses from third parties for technology referenced in this document. To the extent this document contains or refers to documents of third parties, you agree to abide by the terms of any licenses associated with such third party documents, including open source licenses, if any.

© Cable Television Laboratories, Inc., 2011-2014

DISCLAIMER

This document is furnished on an "AS IS" basis and neither CableLabs nor its members provides any representation or warranty, express or implied, regarding the accuracy, completeness, noninfringement, or fitness for a particular purpose of this document, or any document referenced herein. Any use or reliance on the information or opinion in this document is at the risk of the user, and CableLabs and its members shall not be liable for any damage or injury incurred by any person arising out of the completeness, accuracy, or utility of any information or opinion contained in the document.

CableLabs reserves the right to revise this document for any reason including, but not limited to, changes in laws, regulations, or standards promulgated by various entities, technology advances, or changes in equipment design, manufacturing techniques, or operating procedures described, or referred to, herein.

This document is not to be construed to suggest that any affiliated company modify or change any of its products or procedures, nor does this document represent a commitment by CableLabs or any of its members to purchase any product whether or not it meets the characteristics described in the document. Unless granted in a separate written agreement from CableLabs, nothing contained herein shall be construed to confer any license or right to any intellectual property. This document is not to be construed as an endorsement of any product or company or as the adoption or promulgation of any guidelines, standards, or recommendations.

Document Status Sheet

Document Control Number:	DPoE-SP-PHYv1.0-I05-140807			
Document Title:	DPoE Physical Layer Specification			
Revision History:	I01 - Released 02/25/11 I02 - Released 08/30/12 I03 - Released 03/28/13 I04 - Released 03/27/14 I05 - Released 08/07/14			
Date:	August 7, 2014			
Status:	Work in Progress	Draft	Issued	Closed
Distribution Restrictions:	Author Only	CL/Member	CL/Member/Vendor	Public

Key to Document Status Codes

- Work in Progress** An incomplete document, designed to guide discussion and generate feedback that may include several alternative requirements for consideration.
- Draft** A document in specification format considered largely complete, but lacking review by Members and vendors. Drafts are susceptible to substantial change during the review process.
- Issued** A generally public document that has undergone Member and Technology Supplier review, cross-vendor interoperability, and is for Certification testing if applicable. Issued Specifications are subject to the Engineering Change Process.
- Closed** A static document, reviewed, tested, validated, and closed to further engineering change requests to the specification through CableLabs.

Trademarks

CableLabs® is a registered trademark of Cable Television Laboratories, Inc. Other CableLabs marks are listed at <http://www.cablelabs.com/certqual/trademarks>. All other marks are the property of their respective owners.

Contents

1	INTRODUCTION	6
1.1	DPoE Technology Introduction	6
1.2	Scope	6
1.3	Goals	7
1.4	Requirements	7
1.5	Organization of Specifications	8
1.6	DPoE Specifications	8
1.7	Reference Architecture	9
1.8	DPoE Interfaces and Reference Points	10
2	REFERENCES	12
2.1	Normative References	12
2.2	Informative References	13
2.3	Reference Acquisition	14
3	TERMS AND DEFINITIONS	15
3.1	DPoE Elements	15
3.2	Other Terms	16
4	ABBREVIATIONS AND ACRONYMS	17
5	EPON PHY	18
5.1	DPoE Additional PHY Requirements	18
5.1.1	Forward Error Correction	18
5.1.2	1G FEC	18
5.1.3	10G FEC	18
5.2	Raman Interference Mitigation	19
5.3	Optical Monitoring	20
5.4	D-ONU Optical Power Control	20
6	D-ONU UNI: "S" INTERFACE	21
6.1	Physical Interfaces	21
6.2	Logical Interfaces	21
7	DPOE SYSTEM D INTERFACE AND TU INTERFACE	22
ANNEX A	2G-EPON SYSTEM DEFINITION	23
A.1	Overall requirements for the system	23
A.1.1	Protocol Stack	23
A.1.2	2GMII Overview	24
A.1.3	Dual Ten-Bit Interface (DTBI) Requirements	25
A.2	PON Interface Protocol Stack and Requirements	26
A.2.1	PMD Sublayer	26
A.2.2	PMA Sublayer	31
A.2.3	PCS Sublayer	31
A.2.4	RS Sublayer	31
A.2.5	OAM Sublayer	31
A.2.6	Multipoint MAC Control (MPMC) Sublayer	31
APPENDIX I	ACKNOWLEDGMENTS	32
APPENDIX II	REVISION HISTORY	33
II.1	Engineering Change for DPoE-SP-PHYv1.0-I02-120830	33
II.2	Engineering Change for DPoE-SP-PHYv1.0-I03-130328	33

II.3	Engineering Change for DPoE-SP-PHYv1.0-I04-140327.....	33
II.4	Engineering Changes for DPoE-SP-PHYv1.0-I05-140807	33

Figures

Figure 1 - DPoE Reference Architecture	9
Figure 2 - DPoE Interfaces and Reference Points.....	10
Figure 3 - DPoE Elements	15
Figure 4 - Interference Spectra Without and With Raman Mitigation.....	19
Figure 5 - IDLE Pattern Replacement Function	19
Figure 6 - Relationship between the 2G-EPON Protocol Stack and OSI Reference Model.....	24
Figure 7 - 2GMII Signal Definitions at OLT	25
Figure 8 -Definitions of 2GMII signals at ONU.....	25
Figure 9 - Dual Ten-Bit Interface	26
Figure 10 - D-PMD and U-PMD Illustration.....	27

Tables

Table 1 - DPoE Specifications.....	8
Table 2 - DPoE Interface and Reference Point Descriptions.....	11
Table 3 - 2G-EPON Downstream Rate Requirements.....	23
Table 4 - 2G-EPON PMD Type Definitions.....	27
Table 5 - 2000BASE-PX10-D and 2000BASE-PX10-U Transmitter Characteristics.....	28
Table 6 - 2000BASE-PX10-D and 2000BASE-PX10-U Receiver Characteristics	28
Table 7 - 2000BASE-PX20-D and 2000BASE-PX20-U Transmitter Characteristics.....	29
Table 8 - 2000BASE-PX20-D and 2000BASE-PX20-U Receiver Characteristics	29
Table 9 - 2000BASE-PX30-D and 2000BASE-PX30-U Transmitter Characteristics.....	29
Table 10 - 2000BASE-PX30-D and 2000BASE-PX30-U Receiver Characteristics	30
Table 11 - 2000BASE-PX40-D and 2000BASE-PX40-U Receiver Characteristics	30

1 INTRODUCTION

Comcast Corporation, Time Warner Cable, and Bright House Networks collaborated to develop the interoperability requirements to support business services products using Ethernet Passive Optical Network (EPON) as an access technology.

DOCSIS Provisioning of EPON (DPoE) is a joint effort of operators, vendors, and suppliers to support EPON technology using existing DOCSIS-based back office systems and processes.

Ethernet PON or EPON is an [802.3] standard for a passive optical network (PON). A PON is a specific type of multi-access optical network. A multi-access optical network is an optical fiber-based network technology that permits more than two network elements to transmit and receive on the same fiber. Appendix I in [DPoE-SP-ARCHv1.0] has a more detailed explanation of multi-access optical networks.

This version of the DPoE specifications is focused on DOCSIS-based provisioning and operations of Internet Protocol (IP) using DOCSIS High Speed Data (HSD), or IP(HSD) for short, and Metro Ethernet Forum (MEF) services. DPoE Networks offer IP(HSD) services functionally equivalent to DOCSIS networks, where the DPoE System acts like a DOCSIS CMTS, and the DPoE System and DPoE Optical Network Unit (ONU) appear to act like a DOCSIS CM.

1.1 DPoE Technology Introduction¹

DPoE technology was established with the following common requirements already developed by operators. Each of the participant operators had previously selected 1G-EPON and 10G-EPON as the appropriate technology for one or more applications. EPON is a widely deployed technology with a sufficient and large supply of vendors offering a variety of products for each component of the access network. 2G-EPON, as described in Annex A, uses the same 1G upstream as 1G-EPON (operates at the effective rate of 1 Gbps) but provides a 2G downstream (operates at the effective rate of 2 Gbps). With the exception of requirements specified in Annex A, 2G-EPON is expected to meet all of the requirements specified for 1G-EPON. 10G-EPON technology is now backwards compatible with 1G-EPON. A 1G-EPON network can be incrementally upgraded to 10G-EPON, adding or replacing ONUs one at a time if required. 1G-EPON and 10G-EPON are compatible with [SCTE 174] (RFoG).

The EPON protocol [802.3] supports a centralized operator-based controller architecture, with the controller commonly referred to as the Optical Line Terminal (OLT), with low cost Layer 2 access devices (ONU). The basic service mapping architecture in EPON is to map Ethernet (or IP) frame header information (such as addresses, IP DiffServ Code Points, Ethernet Q tag, S-VLAN/C-VLAN ID, ISID, bridge address, or other marking) to a logical circuit called a Logical Link Identifier (LLID) in [802.3]. The service function is similar to that used in DOCSIS networks in many ways because it is based on a centralized scheduler and uses an LLID which functions like an SID, supports both unicast and broadcast, and has other similarities.

At the time when development efforts around the DPoE specifications started, there were no standard management interfaces for the ongoing operations and maintenance of the network, including fault management, performance management, security, etc. Operators already had fully working and scaled-out systems that solve these challenges for DOCSIS networks. One of the primary goals for DPoE specifications was therefore to use the existing DOCSIS back office infrastructure to scale up EPON-based business services.

1.2 Scope

This specification identifies requirements for the EPON PHY for the adaptation or additions to DOCSIS specifications that are required to support DOCSIS Provisioning of EPON.

This specification:

- Specifies interoperable implementations for various DPoE vendors; and
- Specifies additional requirements for EPON PHY layer as used in cable networks which are outside the scope of [802.3] specifications.

¹ Revised per PHYv1.0-N-14.0160-1 and PHYv1.0-N-14.0184-1 on 7/15/14 by JB.

1.3 Goals

Collectively, the operators started the DPoE specification development to accomplish the following objectives:

- Identify and document the common requirements for triple play services for business customers over EPON.
- Adapt DOCSIS-based back office provisioning and operations models to EPON. This is the core objective of DPoE specifications.
- Develop consensus on additional requirements above and beyond DOCSIS specifications to take advantage of the capabilities of EPON. These are focused in the area of Ethernet services and MEF integration.
- Continue to leverage the supply chain and economic benefits of a large base of suppliers and high-volume supply chain in optics, subsystems, and network systems based on a commodity EPON technology. Doing so requires adapting operator processes and networks to the EPON system rather than making any changes to the EPON systems.
- Positioning DPoE specifications to continue to leverage those same benefits for 10G-EPON.
- Work with the established EPON vendor community to assure that these strategies can be effective to mutually develop DPoE Networks, and to create a marketplace for success for multiple vendors to provide solutions for the variety of needs within the operator environment.

1.4 Requirements

Throughout this document, the words that are used to define the significance of particular requirements are capitalized. These words are:

"MUST"	This word means that the item is an absolute requirement of this specification.
"MUST NOT"	This phrase means that the item is an absolute prohibition of this specification.
"SHOULD"	This word means that there may exist valid reasons in particular circumstances to ignore this item, but the full implications should be understood and the case carefully weighed before choosing a different course.
"SHOULD NOT"	This phrase means that there may exist valid reasons in particular circumstances when the listed behavior is acceptable or even useful, but the full implications should be understood and the case carefully weighed before implementing any behavior described with this label.
"MAY"	This word means that this item is truly optional. One vendor may choose to include the item because a particular marketplace requires it or because it enhances the product, for example; another vendor may omit the same item.

1.5 Organization of Specifications

The DPoE specifications are organized around existing DOCSIS specifications. The purpose of matching DPoE specification documents to existing CableLabs DOCSIS, IEEE, IETF, and MEF requirements is to facilitate the mapping of services from existing DOCSIS infrastructure to DPoE infrastructure, and to provide an organization that will be easy to maintain as related (referenced) standards, recommendations, or specifications undergo independent changes.

There are two types of documents in the DPoE specifications. The first includes informative and requirements documents called specifications that detail the specific requirements for products claiming compliance with the specifications. The DPoE specifications also include a new kind of document that does not fit into any of the above categories. The IP Network Elements (IP NE) Requirements [DPoE-SP-IPNEv1.0] are a set of common requirements for the management of IP network elements that operators have developed, which are above and beyond the requirements in DOCSIS specifications, but are nonetheless required in DOCSIS CMTS products today. These are not specifications because no new protocols or algorithms are provided. Most of the requirements in IP NE are existing requirements based on IEEE, IETF, or other network management standards.

The DPoE documents are detailed in Section 1.6 of this document and duplicated, for reference, in each of the DPoE specifications.

1.6 DPoE Specifications²

This document is one in a series of nine (9) documents comprising the DPoE specifications. Collectively these documents represent the operators' requirements for EPON-based commercial services.

Table 1 - DPoE Specifications

Document	Document Title	Description
DPoE-SP-ARCHv1.0	DPoE Architecture Specification	DOCSIS Provisioning of EPON introduction, architecture, and narrative. Specifies fundamental architectural requirements (those that apply to more than one specification). Explains the purpose of each document below.
DPoE-SP-OAMv1.0	DPoE OAM Extensions Specification	Extensions beyond [802.3] requirements.
DPoE-SP-PHYv1.0	DPoE Physical Layer Specification	Using the EPON PHY, the DPoE PHY specification makes mandatory some options within EPON and adds some additional requirements.
DPoE-SP-SECv1.0	DPoE Security and Certificate Specification	Specifications for support for DOCSIS network and system interfaces to provide transparent support of DOCSIS device authentication, code verification, and additional security for a DPoE implementation.
DPoE-SP-IPNEv1.0	DPoE IP Network Element Requirements	Best practices and operator requirements for IP network element management and operations. This document includes CMTS-like IP router requirements. This document recommends practices not currently covered by any existing DOCSIS specifications.
DPoE-SP-MULPIv1.0	DPoE MAC and Upper Layer Protocols Requirements	Specifications for support of a subset of DOCSIS 3.0 MULPI functionality with additional EPON requirements.
DPoE-SP-MEFv1.0	DPoE Metro Ethernet Forum Specification	Specifications for Metro Ethernet services added to DOCSIS static configuration provisioning model.

² Revised per PHYv1.0-N-14.0160-1 on 7/15/14 by JB.

Document	Document Title	Description
DPoE-SP-OSSiv1.0	DPoE Operations and Support System Interface Specification	Specifications for support of a subset of DOCSIS 3.0 OSSI functionality with additional EPON requirements.
DPoE-SP-DEMARCv1.0	DPoE Demarcation Device Specification	Specifications to support the DEMARC Auto-Configuration process to discover and provision a demarcation device connected to a DPoE ONU.

1.7 Reference Architecture

The DPoE reference architecture identifies the elements that a DPoE Network minimally requires to illustrate and communicate the physical hardware and logical software interfaces between the functional subsystems of the DPoE architecture. The principal elements in the architecture are the DPoE System that resides in the operator network, and the DPoE ONU which may be an off the shelf EPON ONU, EPON SFP-ONU, or an EPON ONU with additional subsystems. The remaining elements in the architecture are existing servers and systems in the operator’s network. All of the server elements have connectivity through an IP (TCP/IP) network. Transport of bearer traffic, and (in some cases) Layer 2 OAM signaling is available through either IP or Layer 2 Ethernet-based Network Interfaces.

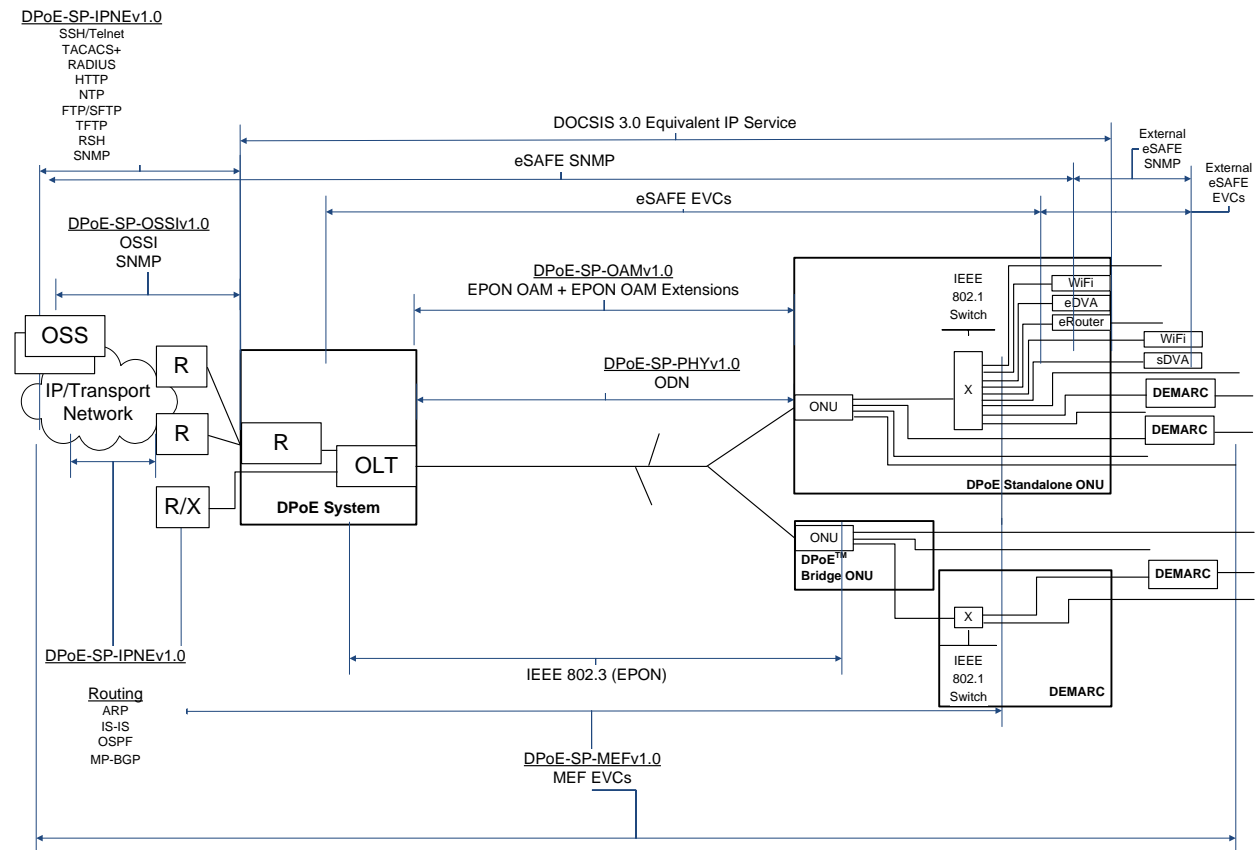

Figure 1 - DPoE Reference Architecture

1.8 DPoE Interfaces and Reference Points

The DPoE interfaces and reference points provide a basis for the description and enumeration of DPoE specifications for the DPoE architecture. Each interface or reference point indicates a point between separate sub-systems. The reference points have protocols that run across them, or have a common format of bearer traffic (with no signaling protocol). All of the interfaces are bi-directional interfaces that support two-way communications. The protocols in DPoE specifications operate within different layers based on the [802.3], [802.1], IETF, MEF, and CableLabs specifications. The C reference points are uni-directional for upstream (C_O) or downstream (C_S) classification, respectively.

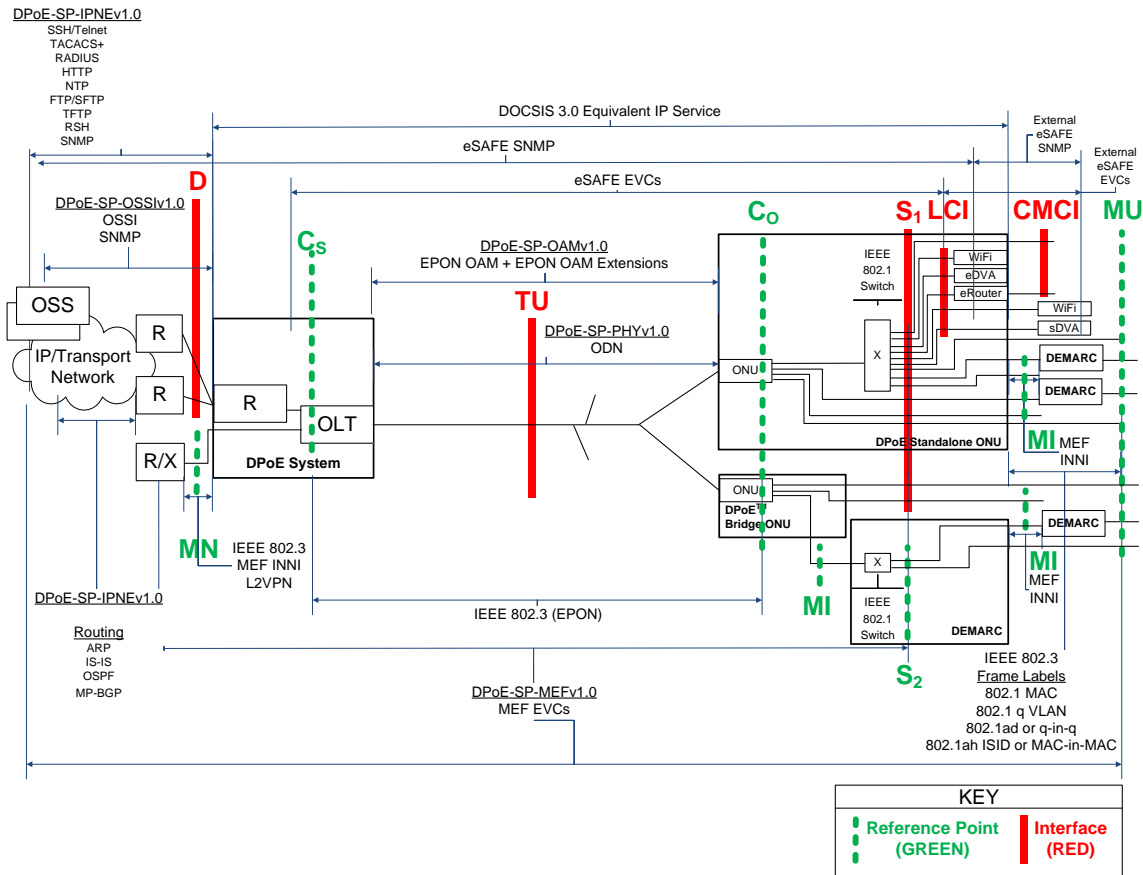

Figure 2 - DPoE Interfaces and Reference Points

Table 2 - DPoE Interface and Reference Point Descriptions

Interface or Reference Point	Interface or Reference Point Description	
MN	The MN interface is an [802.3] interface for Ethernet (or MEF or L2VPN emulated) services only. It serves the role of a MEF INNI or L2VPN NSI. It is an NNI for Metro Ethernet services only.	
D	The D interface is the DOCSIS IP NNI interface. It is an operator network facing interface, sometimes called a Network to Network Interface (NNI) or Network Systems Interface (NSI) in DOCSIS specifications. The D interface allows a DPoE System to communicate with an IP network. The D interface carries all IP management traffic including OSSI and IP NE traffic. The D interface carries all DOCSIS IP service traffic.	
TU	The TU interface is a short form of expressing the interface between the DPoE System and the DPoE ONU.	
C	The C reference point is used for explanation of traffic ingress to a DPoE classifier.	
	C ₀	The C ₀ reference point is used for explanation of traffic ingress to a DPoE ONU upstream classifier.
	C _S	The C _S reference point is used for explanation of traffic ingress to a DPoE System downstream classifier.
S	The S interface is an IEEE 802 interface. The S interface may be an internal interface (such as [802.3] across a GMII SERDES or XGMII interface in an SFP-ONU, SFP+ONU or XFP-ONU) or it may be an external Ethernet interface. S ₁ is an interface for a DPoE Standalone ONU. S ₂ is a reference point used for explanation of services with the DPoE Bridge ONU.	
	S ₁	The S ₁ interfaces are the general case of all interfaces on a DPoE Standalone ONU. S ₁ interfaces may be CMCI, LCI, MI, or MU interfaces.
	S ₂	The S ₂ reference point is used for explanation of traffic ingress to and egress from interfaces on a DEMARC device in a DPoE System. Although there are no specifications or requirements for the S ₂ reference point, informative text refers to the S ₂ reference point to provide the full context for the use of a DPoE Bridge ONU in a DEMARC device providing Metro Ethernet services.
LCI	The Logical CPE Interface (LCI) interface is an eDOCSIS interface as defined in [eDOCSIS]. The eDOCSIS architecture is [802.1d] MAC based according to the DOCSIS 3.0 specifications; however, DOCSIS L2VPN clearly supports [802.1q] switching. In practice, therefore, the eDOCSIS interface consists of a DOCSIS classifier and [802.1] switch as illustrated. The function of a DOCSIS classifier is in part replaced by forwarding (tagging and encapsulation) in MEF and in part covered by classifiers in [DPoE-SP-MULPIv1.0].	
CMCI	CMCI is the DPoE interface equivalent of the DOCSIS Cable Modem CPE Interface as defined in [CMCIv3.0]. This is the service interface for DOCSIS-based IP services.	
MI	MI is usually an S interface (or S reference point) that operates as a MEF INNI. A DPoE ONU that provides a MEF INNI has an MI interface. A DPoE ONU can have MU as an interface and an MI reference point on different S interfaces in a single DPoE ONU. The MI interface or reference point is an [802.3] interface (or reference point) between a DPoE ONU and a DEMARC device.	
MU	MU is usually an S interface (or S reference point) that operates as a MEF UNI. A DPoE ONU that directly provides a MEF UNI (MU) interface has MU as an interface. A DPoE ONU can have MU as an interface and an MI reference point on different S interfaces in a single DPoE ONU. The MU interface or reference point is an [802.3] interface (or reference point) between a DPoE ONU or a DEMARC device and a customer's equipment.	

2 REFERENCES

2.1 Normative References³

In order to claim compliance with this specification, it is necessary to conform to the following standards and other works as indicated, in addition to the other requirements of this specification. Notwithstanding, intellectual property rights may be required to use or implement such normative references. At the time of publication, the editions indicated were valid. All references are subject to revision, and users of this document are encouraged to investigate the possibility of applying the most recent editions of the documents listed below. References are either specific (identified by date of publication, edition number, version number, etc.) or non-specific. For a non-specific reference, the latest version applies.

- [802.1] Refers to entire suite of IEEE 802.1 standards unless otherwise specified.
- [802.1d] IEEE Std 802.1d-2004™, IEEE Standard for Local and Metropolitan Area Networks: Media Access Control (MAC) Bridges
- [802.1q] IEEE Std. 802.1q-2009, IEEE Standard for Local and Metropolitan Area Networks-Virtual Bridged Local Area Networks, January 2010.
- [802.3] IEEE 802.3-2012, IEEE Standard for Ethernet, December 2012.
- [802.3ah] IEEE 802.3ah™-2004: IEEE Standard for Information technology-Telecommunications and information systems-Local and metropolitan area networks-Specific requirements, Part 3: Carrier Sense Multiple Access with Collision Detection (CSMA/CD) Access Method and Physical Layer Specifications, Amendment: Media Access Control Parameters, Physical Layers, and Management Parameters for Subscriber Access Networks, now part of [802.3].
- [802.3av] IEEE 802.3av™-2009, IEEE Standard for Information technology-Telecommunications and information systems-Local and metropolitan area networks-Specific requirements, Part 3 Carrier Sense Multiple Access with Collision Detection (CSMA/CD) Access Method and Physical Layer Specifications Amendment 1: Physical Layer Specifications and Management Parameters for 10Gb/s Passive Optical Networks now part of [802.3].
- [802.3bk] IEEE 802.3bk-2013, Amendment 1: Physical Layer Specifications and Management Parameters for Extended Ethernet Passive Optical Networks
- [DPoE-SP-OAMv1.0] DOCSIS Provisioning of EPON, OAM Extensions Specification, DPoE-SP-OAMv1.0, Cable Television Laboratories, Inc.
- [SFF-8077i] SFF-8077i 10 Gigabit Small Form Factor Pluggable Module, Revision 4.0, released April 13, 2004.
- [SFF-8472] SFF-8472 Specification for Diagnostic Monitoring Interface for Optical Transceivers, Revision 10.4, released January 2009.
- [SFP MSA] INF 8074i Rev 1.0, Small Form-factor Pluggable Multi-Source Agreement, released 12 May 2001.

³ Revised per PHYv1.0-N-14.0160-1 and PHYv1.0-N-14.0184-1 on 7/15/14 by JB.

2.2 Informative References

This specification uses the following informative references.

- [802.1ag] IEEE Std 802.1ag–2007™, IEEE Standard for Local and Metropolitan Area Networks – Virtual Bridged Local Area Networks Amendment 5: Connectivity Fault Management, December 2007.
- [802.3ag] IEEE Std. 802.3ag-2007™, IEEE Standard for Local and Metropolitan Area Networks-Virtual Bridged Local Area Networks-Amendment 5: Connectivity Fault Management, January 2007.
- [CMCIv3.0] Data-Over-Cable Service Interface Specifications, Cable Modem to Customer Premise Equipment Interface Specification, CM-SP-CMCIv3.0, Cable Television Laboratories, Inc.
- [DOCSIS] Refers to entire suite of DOCSIS 3.0 specifications unless otherwise specified.
- [DPoE-SP-ARCHv1.0] DOCSIS Provisioning of EPON, DPoE Architecture Specification, DPoE-SP-ARCHv1.0, Cable Television Laboratories, Inc.
- [DPoE-SP-DEMARCv1.0] DPoE-SP-DEMARCv1.0, DOCSIS Provisioning of EPON, DPoE Demarcation Device Specification, Cable Television Laboratories, Inc.
- [DPoE-SP-IPNEv1.0] DOCSIS Provisioning of EPON, IP Network Element Requirements, DPoE-SP-IPNEv1.0, Cable Television Laboratories, Inc.
- [DPoE-SP-MEFv1.0] DOCSIS Provisioning of EPON, Metro Ethernet Forum Specification, DPoE-SP-MEFv1.0, Cable Television Laboratories, Inc.
- [DPoE-SP-MULPIv1.0] DOCSIS Provisioning of EPON, MAC and Upper Layer Protocols Requirements, DPoE-SP-MULPIv1.0, Cable Television Laboratories, Inc.
- [DPoE-SP-OSSIV1.0] DOCSIS Provisioning of EPON, Operations and Support System Interface Specification, DPoE-SP-OSSIV1.0, Cable Television Laboratories, Inc.
- [DPoE-SP-SECV1.0] DOCSIS Provisioning of EPON, Security and Certificate Specification, DPoE-SP-SECV1.0, Cable Television Laboratories, Inc.
- [eDOCSIS] CM-SP-eDOCSIS, Data-Over-Cable Service Interface Specifications, eDOCSIS Specification, Cable Television Laboratories, Inc.
- [MULPIv3.0] CM-SP-MULPIv3.0, Data-Over-Cable Service Interface Specifications, MAC and Upper Layer Protocols Interface Specification, Cable Television Laboratories, Inc.
- [PHYv3.0] Data-Over-Cable Service Interface Specifications, Physical Layer Specification, CM-SP-PHYv3.0, Cable Television Laboratories, Inc.
- [RFC 2011] IETF RFC 2011, SNMPv2 Management Information Base for the Internet Protocol using SMIV2, K. McCloghrie, November 1996.
- [RFC 2863] IETF RFC 2863, The Interfaces Group MIB, K. McCloghrie, F. Kastenholz, June 2000.
- [RFC 3418] IETF RFC 3418, Management Information Base (MIB) for the Simple Network Management Protocol (SNMP), R. Presuhn, Ed., June 2000.
- [RFC 4188] IETF RFC 4188, K. Norseth, Ed. and E. Bell, Ed., Definitions of Managed Objects for Bridges, September 2005.
- [RFC 4293] IETF RFC 4293, Management Information Base for the Internet Protocol (IP), S. Routhier, April 2006.
- [SCTE 174] SCTE 174 2010, Radio Frequency over Glass Fiber-to-the-Home Specification

2.3 Reference Acquisition

- Cable Television Laboratories, Inc., 858 Coal Creek Circle, Louisville, CO 80027; Phone +1-303-661-9100; Fax +1-303-661-9199; <http://www.cablelabs.com>
- Internet Engineering Task Force (IETF) Secretariat, 48377 Fremont Blvd., Suite 117, Fremont, California 94538, USA, Phone: +1-510-492-4080, Fax: +1-510-492-4001, <http://www.ietf.org>
- Institute of Electrical and Electronics Engineers (IEEE), +1 800 422 4633 (USA and Canada); <http://www.ieee.org>
- Small Form Factor Committee (SFF), <http://www.sffcommittee.com>
- SCTE, Society of Cable Telecommunications Engineers Inc., 140 Philips Road, Exton, PA 19341
Phone: +1-800-542-5040, Fax: +1-610-363-5898, Internet: <http://www.scte.org/>

3 TERMS AND DEFINITIONS

3.1 DPoE Elements

- DPoE Network** This term means the entire network described in Figure 3 from the D or MN interface to the LCI, S, MI, or MU interface (see Figure 2 for interface and reference points), depending on the service being described. In no case does the term DPoE Network ever include a DEMARC device.
- DPoE System** This term means all of the collected elements that provide the DPoE function within the operator's network facilities. This includes the EPON OLT function, DOCSIS service functions required for the D interface, Metro Ethernet service functions required for the MN interface, and IP NE element management, routing and forwarding functions specified in [DPoE-SP-IPNEv1.0]. The DPoE System is depicted in Figure 3.
- DPoE ONU** This term means a DPoE-capable ONU that complies with all of the DPoE specifications. There are two types of DPoE ONUs. These are the DPoE Standalone ONU and the DPoE Bridge ONU.
- DPoE Standalone ONU** This term means a DPoE ONU that is a standalone ONU capable of providing IP or Ethernet services directly to customer premise equipment or transport of traffic to an external DEMARC device.
- DPoE Bridge ONU** This term means a DPoE ONU that is capable of [802.1] forwarding but cannot do all of the encapsulation functions required to be a DPoE Standalone ONU. Examples include an SFP-ONU and some simple EPON chipset-only based ONUs.
- DEMARC** Short form of "Demarcation Device." This term means the device, owned and operated by the operator that provides the demarcation (sometimes called the UNI interface) to the customer. Some architectures describe this device as the CPE (as in DOCSIS, DSL, or Broadband Forum Models) or the NID (as in the MEF model).

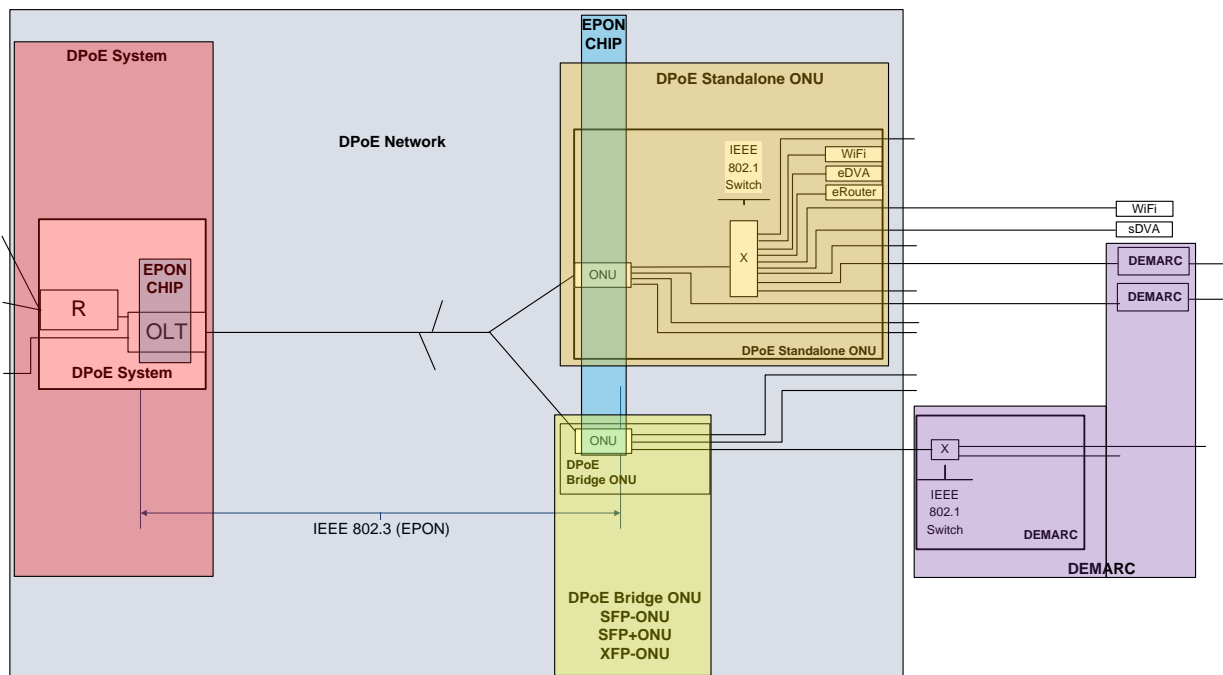

Figure 3 - DPoE Elements

3.2 Other Terms⁴

1G-EPON	EPON as first defined in [802.3ah], now part of [802.3]
2G-EPON	EPON as defined in Annex A, 2G-EPON System Definition
10G-EPON	EPON as first defined in [802.3av], now part of [802.3]
Cable Modem CPE Interface	CMCI as defined in [MULPIv3.0]
Customer Premise Equipment (CPE)	Customer Premise Equipment as defined in [DOCSIS]
Ethernet Passive Optical Network (EPON)	Refers to 1G-EPON, 2G-EPON, and 10G-EPON collectively
EPON Operations and Maintenance Messaging (OAM)	EPON OAM messaging as defined in [802.3] and [DPoE-SP-OAMv1.0]; Ethernet OAM is not the same as EPON OAM; Ethernet OAM is [802.1ag]
Logical CPE Interface	LCI as defined in [eDOCSIS]
Network Interface Device (NID)	A DEMARC device in DPoE specifications

⁴ Revised per PHYv1.0-N-14.0160-1 and PHYv1.0-N-14.0184-1 on 7/15/14 by JB.

4 ABBREVIATIONS AND ACRONYMS

This specification uses the following abbreviations:

BER	Bit error ratio
CMCI	Cable Modem CPE Interface
CoS	Class of Service
DEMARC	Demarcation Device
DoS	Denial of Service
DPoE	DOCSIS Provisioning and operations of EPON
eCM	embedded Cable Modem
eDVA	embedded Digital Voice Adapter
EPON	Ethernet Passive Optical Network
EVC	Ethernet Virtual Connection
FEC	Forward error correction
IP	Internet Protocol
L2VPN	Layer two virtual network
LCI	Logical CPE Interface
LLID	Logical Link IDentifier
MPCP	Multipoint Control Protocol
MEF	Metro Ethernet Forum
ODN	Optical distribution network
OLT	Optical Line Termination
ONU	Optical Network Unit
OSC	Optical Splitter Combiner
PCS	Physical Coding Sublayer
PHY	Physical Layer
PMA	Physical Medium Attachment
PMD	Physical Media Dependent (Sublayer)
PON	Passive optical network
R	IP Router
SFP	Small Form-factor Pluggable
SFP+	Small Form-factor Pluggable Plus (+)
UNI	User Network Interface
X	IEEE Ethernet Switch (Generic)
XFP	X Form-factor Pluggable

5 EPON PHY⁵

The specifications for the EPON PHY are in [802.3], [802.3av], [802.3bk], and Annex A of this specification. [802.3] contains specifications for optical module wavelengths, receiver sensitivity, and other parameters defining the EPON physical layer used in DPoE networks. Details of wavelength planning, supported optical budgets, and split ratios for particular deployments are outside the scope of this specification.

5.1 DPoE Additional PHY Requirements

DPoE Systems **MUST** support all of the Physical Media Dependent (PMD) classes defined in [802.3], Clause 60 (1G-EPON), Clause 75 (10G-EPON) and extensions to these clauses specified in [802.3bk].

DPoE Systems **SHOULD** support the additional system requirements defined in Annex A in this document. If a DPoE System supports these extensions, the DPoE System **MUST** comply with all of the required system functionality defined there.

A DPoE ONU **SHOULD** support the additional ONU requirements defined in Annex A in this document. If a DPoE ONU supports these extensions, the DPoE ONU **MUST** comply with all of the required ONU functionality defined there.

5.1.1 Forward Error Correction

The DPoE System **MUST** support the Forward Error Correction (FEC) methods defined in [802.3], with the additional capabilities as defined in this section. The DPoE ONU **MUST** also support the Forward Error Correction (FEC) methods defined in [802.3], with the additional capabilities defined in this section.

5.1.2 1G FEC

A DPoE System **MUST** support FEC as defined in [802.3] for 1G-EPON. A DPoE ONU **MUST** support FEC as defined in [802.3] for 1G-EPON.

The DPoE System **MUST** support different FEC states (enabled / disabled) in the upstream and downstream directions. Correspondingly, the DPoE ONU **MUST** support different FEC states (enabled / disabled) in the upstream and downstream directions.

The DPoE System **MUST** support enabling FEC on a per logical link basis. The DPoE ONU **MUST** also support enabling FEC on a per logical link basis. FEC may be individually enabled for one or more of the logical links on the PON, may be enabled for all logical links on the PON, or may be disabled altogether, according to operator provisioning.

At the time of registration, the DPoE ONU **MUST** automatically detect the presence of FEC-encoded frames in the downstream, and set the initial state of FEC for the link to be registered in the upstream to match. The DPoE System **MUST** be able to enable or disable FEC encoding according to operator provisioning via OAM after the link has registered.

5.1.3 10G FEC⁶

A DPoE System **MUST** support FEC as defined in [802.3] for 10G-EPON. A DPoE ONU **MUST** support FEC as defined in [802.3] for 10G-EPON.

A DPoE System **MAY** support disabling FEC for all 10G-EPON DPoE ONUs connected to the given TUL interface. Note that due to the stream-based nature of FEC in 10G-EPON, there is no way to support disabling or enabling FEC on per logical link basis.

If the FEC disabling function is supported, the operator is responsible for making sure that the FEC for the given TUL interface is disabled only when selected or all connected DPoE ONUs have sufficient power budget margin to achieve error-free operation with FEC disabled. Given that changing FEC state (enabling or disabling) for 10G-EPON TUL interface is service affecting, the operator needs to account for the DPoE ONU re-registration process when changes to the FEC state are made.

⁵ Revised per PHYv1.0-N-14.0160-1 on 7/15/14 by JB.

⁶ Revised per PHYv1.0-N-12.0037-1 on 7/19/12 and per PHYv1.0-N-12.0054-1 on 2/13/13 by JB.

A 10G-EPON DPoE ONU MAY support disabling FEC, if configured appropriately by the DPoE System. A 10G-EPON DPoE ONU MAY automatically detect the presence of an FEC encoded downstream, and set the initial state of its upstream FEC to match.

- (a) Requirements associated with support for disabling FEC on 10G-EPON links will become mandatory once the appropriate mechanisms are defined in IEEE Std 802.3.

5.2 Raman Interference Mitigation

The DPoE System MUST provide means for reducing Raman interference of the EPON downstream with other optical wavelengths by replacing [802.3] IDLE time by randomized frames as defined in this section.

Standard 1 Gbit/s Ethernet transmission features transmission of an IDLE pattern (comprising an alternating sequences of 1s and 0s) when there is no subscriber data to be transmitted. The high frequency component of such a data pattern produces interference affecting other optical wavelengths. In the [802.3] based DPoE Network, the downstream optical channel transmitted at the central wavelength of 1490 nm (digital data) produces a power spike at the optical channel transmitted at the central wavelength of 1550 nm (RF video). The Raman mitigation technique reduces this interference by minimizing the power transmitted in the high frequency component, as shown in Figure 4 below.

The standard Ethernet IDLE is replaced by an Ethernet frame carrying a payload with a random pattern, spreading transmitted optical power over a wider spectrum, reducing the interference at specific other wavelengths.



Figure 4 - Interference Spectra Without and With Raman Mitigation

The DPoE System MUST always transmit actual network data in the downstream if such is available.

If the DPoE System detects a sufficiently long idle period on the NNI interface, with the size equal to a minimum Ethernet frame (64 bytes plus 8 bytes of preamble and 12 bytes of IPG), the DPoE System MUST replace this IDLE frame with an internally generated Ethernet frame with a random payload, as described above. This frame MUST be sent on a unicast LLID that is not connected to any DPoE ONU on the particular DPoE System TU (PON) interface, ensuring thus that no DPoE ONU can receive such a frame. The DPoE System MUST generate a payload for this frame such that it comprises of a sequence of uniformly distributed random values.

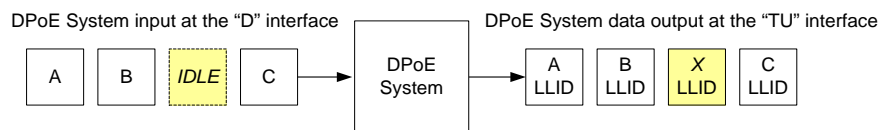

Figure 5 - IDLE Pattern Replacement Function

5.3 Optical Monitoring

A DPoE System MUST support all optical monitoring values as specified in [SFF-8472], including monitoring received optical power, transmit power, transmit bias current, internal voltage, and temperature. Similarly the DPoE ONU MUST support all optical monitoring values as specified in [SFF-8472], including monitoring received optical power, transmit power, transmit bias current, internal voltage, and temperature.

A DPoE System MUST be able to report received optical power on a per logical link basis, as well as reporting received optical power during idle time on the PON upstream.

5.4 D-ONU Optical Power Control

One possible failure mode for a D-ONU is for the laser driver to remain in the enabled state outside of the assigned transmission slot, continually generating light into the PON, interfering with transmissions of other D-ONUs in the upstream. The DPoE System MUST be able to isolate such failed D-ONUs from the PON by disabling their transmitter until the D-ONU can be replaced. The DPoE System disables a D-ONU laser by means of a specialized DPoE OAM message. A D-ONU MUST support an optical power disable command from the [DPoE-SP-OAMv1.0].

A D-ONU MUST be able to disconnect the power supply from the optical module under software control. A D-ONU MUST be able to separately control the power supplies to the transmit and receive paths of the optical module. A DPoE System MUST be able to send an OAM message to the D-ONU to signal optical power shutdown. If the DPoE System sends such a message, the D-ONU MUST turn off or disconnect the power to the optical module. Once the optical module is disconnected, the DPoE System cannot signal the D-ONU to turn on the power. Therefore, a D-ONU that implements such a feature MUST retain this setting when it is rebooted or power-cycled (in non-volatile storage). The D-ONU MAY remove this setting if it resets by means other than a software reboot or power-cycle (for example a RESET button or similar means).

DPoE Bridge ONU that complies with the [SFP MSA] SHOULD be able to disconnect the power supply from the optical module (within the SFP module) under software control. A DPoE Bridge ONU that complies with the [SFP MSA] SHOULD be able to separately control the power supplies to the transmit and receive paths of the optical module within the SFP module. These requirements apply to the optical module within the DPoE Bridge ONU and do not apply to the SFP module itself, because the transmit and received power pins for the SFP module supply power (in parallel) to both the optical and Layer 2 subsystems within the SFP ONU.

The procedure used to detect malfunctioning D-ONUs, and decide whether to disable them or not, is outside the scope of this specification. In general, network error statistics are used to detect any transmission problems, and malfunctioning D-ONUs are distinguished from working D-ONUs by disabling their lasers temporarily. Once the specific D-ONU has been identified as the source of the problem, it is permanently disabled using the DPoE OAM.

A DPoE System MUST provide the operator the capability to turn on or off such a rogue D-ONU detection function for each PON and for an entire DPoE System.

6 D-ONU UNI: "S" INTERFACE

The S interface in Figure 2 is the User to Network Interface (UNI). DPoE Systems support two types of S interfaces. These are either physical or logical interfaces. Although logical interfaces do not necessarily connect to the CPE, the transport of services to logical and physical interfaces is the same. Any S interface that is configured as a CMCI, MI, or MU interface is a Physical Interface.

6.1 Physical Interfaces

DPoE Standalone ONUs and DPoE Bridge ONUs that do not comply with the [SFP MSA] MUST support standard Ethernet interfaces for the S interfaces configured as (CMCI, MI, or MU) physical interfaces, as defined in [802.3].

A DPoE Bridge ONU that complies with the [SFP MSA] MUST support the standard SFP interface defined in the [SFP MSA]. A DPoE Bridge ONU that complies with the [SFP MSA] MUST also support the digital management interface defined in [SFF-8472].

6.2 Logical Interfaces

In addition to a physical interface, a D-ONU MAY have a logical Ethernet [802.3] interface. This interface could be used to provide an Ethernet transport across the PON from the DPoE System to a real physical interface within the D-ONU package. It could be a sub-interface to a switch or bridge group within the D-ONU, or a sub-interface on an [802.3] interface of a real Physical Interface as in Section 6.1 above.

7 DPOE SYSTEM D INTERFACE AND TU INTERFACE⁷

The 1G-EPON DPoE System SHOULD support SFP ([SFF-8472]-compliant) pluggable 1G-EPON optics at the TU interface. The DPoE System supporting SFP pluggable 1G-EPON optics MUST support third-party optics subject to power requirements of the SFP cage. In practical terms, this means that a DPoE System supporting pluggable 1G-EPON optics is expected to accept 1G-EPON pluggable third-party vendors, as long as the power, thermal, and other requirements of the SFP cage are met.

The 10G-EPON DPoE System SHOULD support SFP+ ([SFF-8077i]-compliant) or XFP ([SFF-8077i]-compliant) pluggable 10G-EPON optics at the TU interface. The DPoE System supporting SFP+ or XFP pluggable 10G-EPON optics MUST support third-party optics subject to power requirements of the SFP+ or XFP cage. In practical terms, this means that a DPoE System supporting pluggable 10G-EPON optics is expected to accept 10G-EPON pluggable third-party vendors, as long as the power, thermal, and other requirements of the SFP+ or XFP cage are met.

The 10G-EPON DPoE System SHOULD support SFP ([SFF-8472]-compliant), SFP+ ([SFF-8077i]-compliant), or XFP ([SFF-8077i]-compliant), or other pluggable optics at the D/MN interface. The DPoE System supporting such pluggable optics at the D/MN interface MUST support third-party optics subject to power requirements of the selected pluggable cage. In practical terms, this means that a DPoE System supporting pluggable optics at the D/MN is expected to accept pluggable third-party vendors, as long as the power, thermal, and other requirements of the selected pluggable cage are met.

⁷ Section added per PHYv1.0-N-14.0121-1 on 3/3/14 by JB.

Annex A 2G-EPON System Definition⁸

A.1 Overall requirements for the system

A DPoE System that supports 2G-EPON MUST meet all 1G-EPON DPoE requirements, except where specified differently in this annex.

A D ONU that supports 2G-EPON MUST meet all 1G-EPON D ONU requirements, except where specified differently in this annex.

Coding and rate

The 2G-EPON DPoE System supports two rate modes in the downstream:

- 1G Mode
- 2G Mode

When a DPoE System that supports 2G-EPON operates in 1G Mode, it uses the same 8B/10B coding as a DPoE System that supports 1G-EPON. When a DPoE System that supports 2G-EPON works in 2G Mode, its internal data width is 16 bits, using double 8B/10B coding (i.e. low 8-bit and high 8-bit respectively use 8B/10B coding independently).

The 2G-EPON downstream can support 2.5 Gbps rate (after double 8B/10B coding), its upstream supports 1.25Gbps rate (after 8B/10B coding). The line rate of 2.5 Gbps corresponds to double 8B/10B coding of 2 Gbps.

A DPoE System that supports 2G-EPON MUST meet the 2G-EPON downstream rate requirements in Table 3.

Table 3 - 2G-EPON Downstream Rate Requirements

EPON system	Coding	Line rate (GBd)	Bit rate (Gbps)	Mode of Operation
1G-EPON	8B/10B	1.25	1	NA
2G-EPON	Double 8B/10B	2.5	2	2G Mode
	8B/10B	1.25	1	1G Mode
Note1: Bit rate means the transmitter's rate before 8B/10B coding, corresponding to the rate at 2GMII and GMII interface of protocol stack.				
Note 2: 1G-EPON rate is used for comparison reference.				

A.1.1 Protocol Stack

Figure 6 illustrates the 2G-EPON protocol stack and the relationship between the protocol stack and the ISO/IEC OSI reference model.

⁸ Annex added per PHYv1.0-N-14.0184-1 on 7/15/14 by JB.

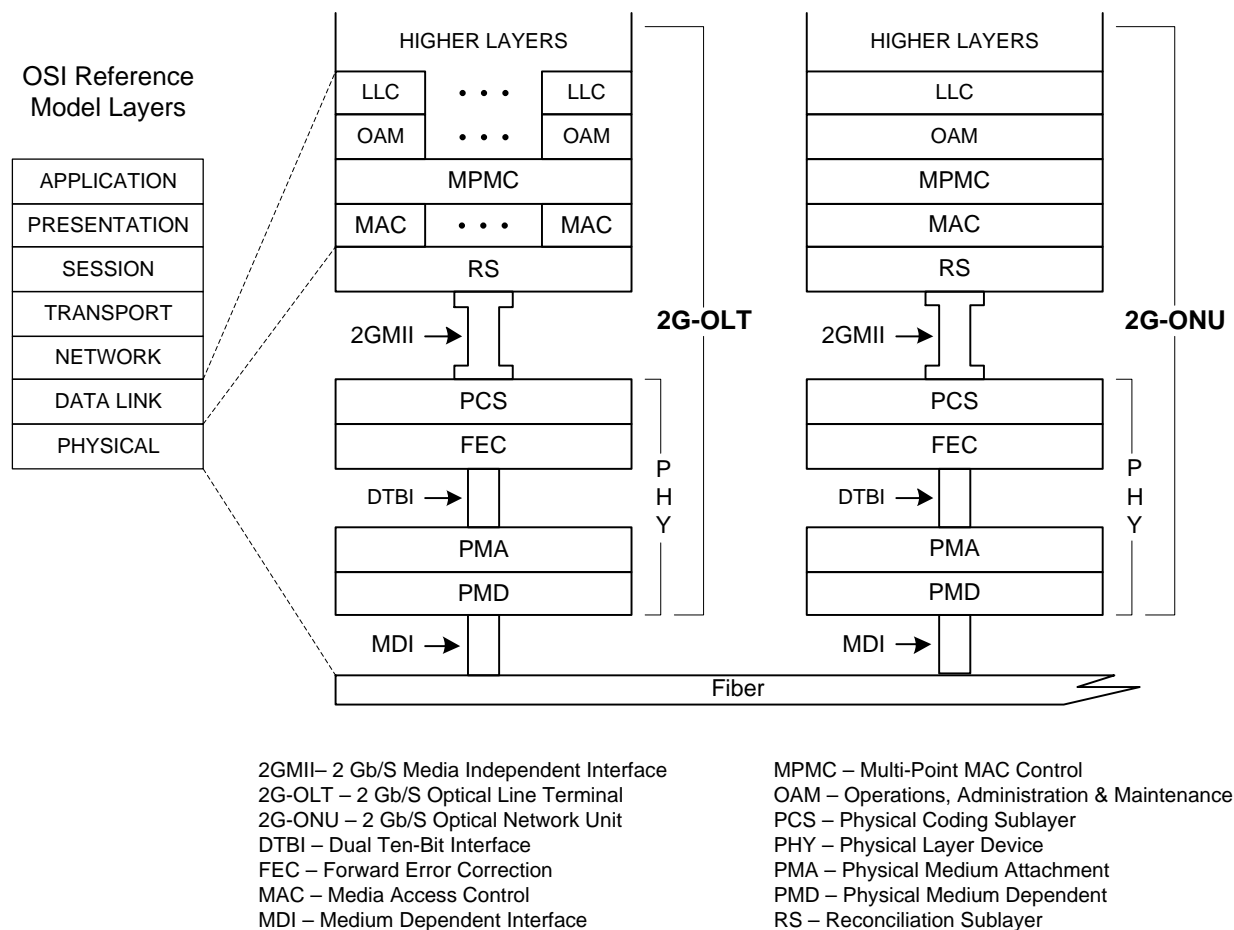

Figure 6 - Relationship between the 2G-EPON Protocol Stack and OSI Reference Model

A.1.2 2GMII Overview

2GMII provides the media-independent interface between the 2G-EPON MAC layer and PHY layer. It is located between the RS sublayer and the PCS sublayer and supports the following features:

- Full duplex data transmitting and receiving operation.
- Full duplex transmitting and receiving with downstream 2 Gbps and upstream 1 Gbps, or full duplex transmitting and receiving with downstream 1 Gbps and upstream 1 Gbps.
- Data and delimiting sync with reference clock.
- In 2 Gbps rate mode, provide independent downstream 16 bit-width data and upstream 8-bit width data. In 1 Gbps rate mode, provide independent downstream 8-bit width data and independent upstream 8-bit width data.

The definitions of 2GMII signals at the OLT are shown in Figure 7; the definitions of these signals are the same as those in GMII.

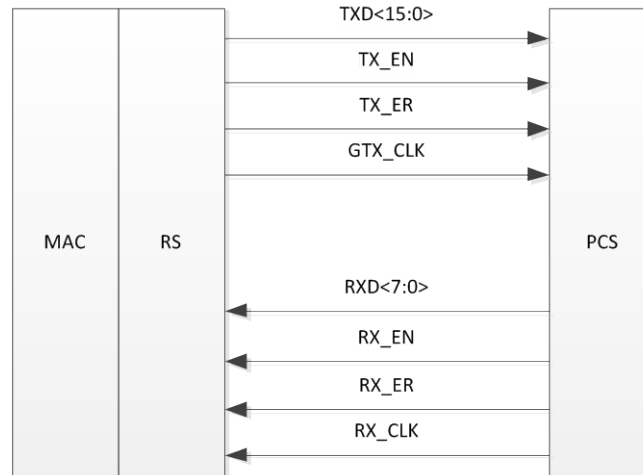

Figure 7 - 2GMII Signal Definitions at OLT

The definitions of 2GMII signals at the ONU are shown in Figure 8; the definitions of these signals are the same as those in GMII.

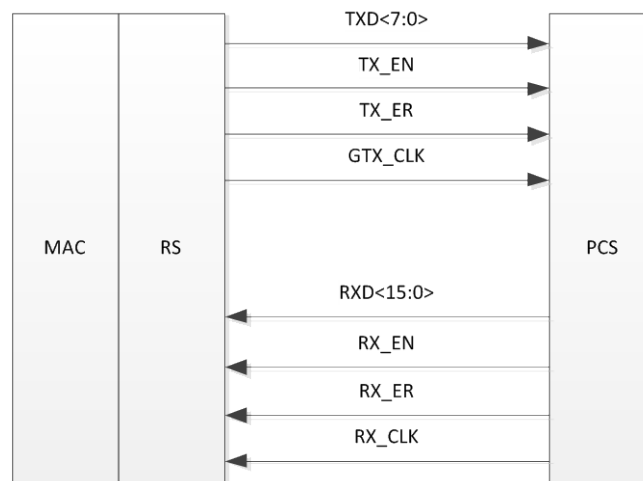

Figure 8 -Definitions of 2GMII signals at ONU

When a DPoE system or ONU that supports 2G-EPON is in 1G Mode, 2GMII only uses low 8-bit data group (bits <7:0>), and its operation mode is the same as GMII.

A.1.3 Dual Ten-Bit Interface (DTBI) Requirements

The 2G-EPON DTBI is located between the PCS and the PMA and supports full duplex data code group transmission. Therefore, the data bit number that the OLT sends is double 10-bit, and the data bit number that it receives is 10-bit. The data bit number that the ONU sends is 10-bit, and the data bit number that the ONU receives is double 10-bit.

Each group of 10-bit data bus is the same as the 10-bit data bus of the TBI in 1G-EPON and denotes one 8B/10B code group data with a clock frequency of 125 MHz. The dual ten-bit interface is illustrated in Figure 9. See the 1G-EPON requirements in [802.3] for further details.

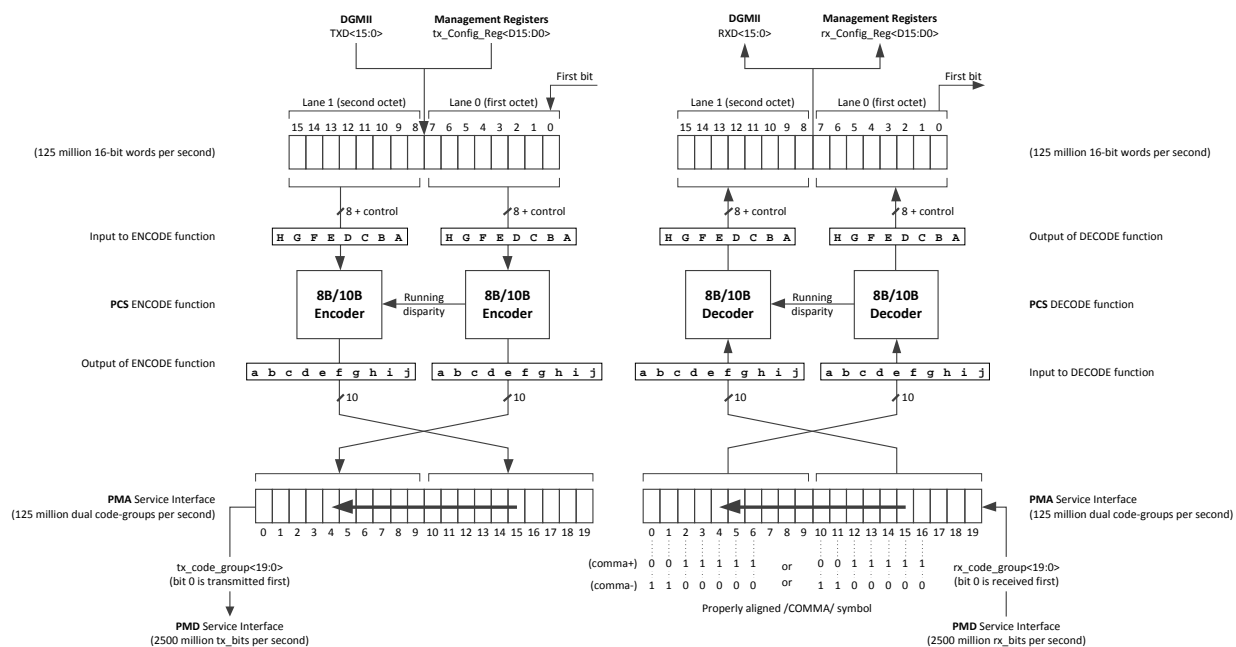

Figure 9 - Dual Ten-Bit Interface

When 2G-EPON operates in 1G Mode, the DTBI uses the first group of 10-bit data bus (i.e. the low 10-bit), and its operation mode is the same as TBI.

A.2 PON Interface Protocol Stack and Requirements

A.2.1 PMD Sublayer

A.2.1.1 PMD Sublayer Basic Requirements

The PMD sublayer of a DPoE System that supports 2G-EPON SHOULD support the following power classes:

- 2000BASE-PX10
- 2000BASE-PX20
- 2000BASE-PX30
- 2000BASE-PX40

The PMD sublayer of a D-ONU that supports 2G-EPON SHOULD support the following power classes:

- 2000BASE-PX10
- 2000BASE-PX20
- 2000BASE-PX30
- 2000BASE-PX40

These power classes are collectively referred to as 2000BASE-PX⁹.

2000BASE-PX has the following features:

- P2MP fiber transmission
- In single-mode fiber, 2000 Mbps or 1000 Mbps rate for downstream; 1000 Mbps rate for upstream. The transmission range is 20 km.
- At the physical layer service interface, BER is not more than 10⁻¹².

The single downstream PMD (D-PMD) in the 2G-EPON system sends data to multiple upstream PMDs (U-PMDs) via broadcasting mode in the downstream direction (D-PMD to U-PMD) and receives bursty data from multiple U-PMDs in the upstream direction. Upstream and downstream share the same single fiber.

One end of 2000BASE-PX uses 2000BASE-PX-U PMD, and the other end uses 2000BASE-PX-D PMD, as shown in Figure 10. The suffix “U” and “D” respectively are used to denote the receiving and transmitting direction at the link's opposite end. If the network uses FEC, it can increase split ratio or transmission range. The max transmission range is not restricted by this standard.

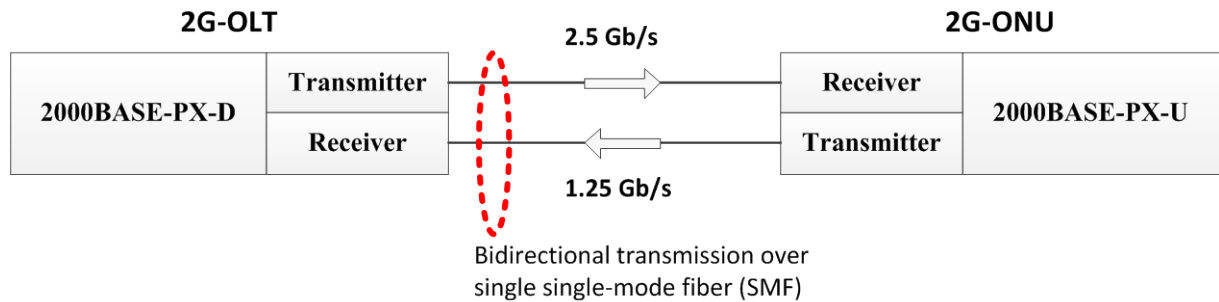

Figure 10 - D-PMD and U-PMD Illustration

Table 4 defines the basic PMD types for 2G-EPON.

Table 4 - 2G-EPON PMD Type Definitions

Description	2000BASE-PX10-U		2000BASE-PX10-D		2000BASE-PX20-U		2000BASE-PX20-D		2000BASE-PX30-U		2000BASE-PX30-D		2000BASE-PX40-U		2000BASE-PX40-D		Unit
	U	D	U	D	U	D	U	D	U	D	U	D	U	D			
Fiber type	IEC 60793-2 B1.1, B1.3 SMF								IEC 60793-2 B1.1, B1.3 SMF, ITU-T G.652, G.657 SMF								--
Number of Fibers	1																--
Rated Transmitting Wavelength			1310	1490	1310	1490	1310	1490	1310	1490	1310	1490	1310	1490	1310	1490	nm
Transmitting Direction	U	D	U	D	U	D	U	D	U	D	U	D	U	D	U	D	
Min Range (Note 1)	0.5 m – 10 km				0.5 m – 20 km												
Max Channel Insertion Loss (Note 2)	20	19.5	24	23.5	29	29	33	33	29	29	33	33	29	29	33	33	dB
Min Channel Insertion Loss	5		10	10	15	15	18	18	15	15	18	18	15	15	18	18	dB

⁹ The 2000BASE-PX PMD is not defined in [802.3]. It is the 1000BASE-X PMD operating at twice the bit rate of 1000BASE-PX; the functionality of individual sublayers is unchanged.

Description	2000BASE-PX10-U	2000BASE-PX10-D	2000BASE-PX20-U	2000BASE-PX20-D	2000BASE-PX30-U	2000BASE-PX30-D	2000BASE-PX40-U	2000BASE-PX40-D	Unit
Note 1: In a FEC enabled link, the minimum range may be increased, or, links with a higher channel insertion loss may be used. Note 2: At nominal transmit wavelength.									

A.2.1.2 **Transceiver PMD to MDI Optical Specifications for 2000BASE-PX10-D and 2000BASE-PX10U**

A.2.1.2.1 **Transmitter Optical Specifications**

DPoE System 2000BASE-PX10-D transmitters MUST meet the specifications defined in Table 60–3 of [802.3bk], with the exception of the Wavelength Range parameter.

DPoE System 2000BASE-PX10-D transmitters MUST meet the Wavelength Range specification defined in Table 5.

D-ONU 2000BASE-PX10-U transmitters MUST meet the specifications defined in Table 60–3 of [802.3bk], with the exception of the Wavelength Range parameter.

D-ONU 2000BASE-PX10-U transmitters MUST meet the Wavelength Range specification defined in Table 5.

Table 5 - 2000BASE-PX10-D and 2000BASE-PX10-U Transmitter Characteristics

Parameter	2000BASE-PX10-D Transmitter	2000BASE-PX10-U Transmitter	Unit
Wavelength Range (Note 1)	1480 – 1500	1300 – 1320	nm
Note 1: Represents $\pm 1\sigma$ range of RMS spectral width central wavelength.			

A.2.1.2.2 **Receiver Optical Specifications**

DPoE System 2000BASE-PX10-U receivers MUST meet the specifications defined Table 60–5 of [802.3bk], with the exception of the Wavelength Range parameter.

DPoE System 2000BASE-PX10-U receivers MUST meet the Wavelength Range specification defined in Table 6.

D ONU 2000BASE-PX10-D receivers MUST meet the specifications defined Table 60–5 of [802.3bk], with the exception of the Wavelength Range parameter. D ONU 2000BASE-PX10-D receivers MUST meet the Wavelength Range specification defined in Table 6.

Table 6 - 2000BASE-PX10-D and 2000BASE-PX10-U Receiver Characteristics

Description	2000BASE-PX10-D Receiver	2000BASE-PX10-U Receiver	Unit
Wavelength Range	1300 – 1320	1480 – 1500	nm

A.2.1.3 **Transceiver PMD to MDI Optical Specifications for 2000BASE-PX20-D and 2000BASE-PX20U**

A.2.1.3.1 **Transmitter Optical Specifications**

DPoE System 2000BASE-PX20-D transmitters MUST meet the specifications defined in Table 60–6 of [802.3bk], with the exception of the Wavelength Range parameter.

DPoE System 2000BASE-PX20-D transmitters MUST meet the Wavelength Range specification defined in Table 7.

D-ONU 2000BASE-PX20-U transmitters MUST meet the specifications defined in Table 60–6 of [802.3bk], with the exception of the Wavelength Range parameter.

D-ONU 2000BASE-PX20-U transmitters MUST meet the Wavelength Range specification defined in Table 7.

Table 7 - 2000BASE-PX20-D and 2000BASE-PX20-U Transmitter Characteristics

Parameter	2000BASE-PX20-D Transmitter	2000BASE-PX20-U Transmitter	Unit
Wavelength Range (Note 1)	1480 – 1500	1300 – 1320	nm
Note 1: Represents $\pm 1\sigma$ range of RMS spectral width central wavelength.			

A.2.1.3.2 Receiver Optical Specifications

DPoE System 2000BASE-PX20-U receivers MUST meet the specifications defined Table 60–8 of [802.3bk], with the exception of the Wavelength Range parameter.

DPoE System 2000BASE-PX20-U receivers MUST meet the Wavelength Range specification defined in Table 8.

D ONU 2000BASE-PX20-D receivers MUST meet the specifications defined Table 60–8 of [802.3bk], with the exception of the Wavelength Range parameter.

DONU 2000BASE-PX20-D receivers MUST meet the Wavelength Range specification defined in Table 8.

Table 8 - 2000BASE-PX20-D and 2000BASE-PX20-U Receiver Characteristics

Description	2000BASE-PX20-D Receiver	2000BASE-PX20-U Receiver	Unit
Wavelength Range	1300 – 1320	1480 – 1500	nm

A.2.1.4 Transceiver PMD to MDI Optical Specifications for 2000BASE-PX30-D and 2000BASE-PX30-U

A.2.1.4.1 Transmitter Optical Specifications

DPoE System 2000BASE-PX30-D transmitters MUST meet the specifications defined in Table 60–8a of [802.3bk], with the exception of the Wavelength Range parameter.

DPoE System 2000BASE-PX30-D transmitters MUST meet the Wavelength Range specification defined in Table 9.

D-ONU 2000BASE-PX30-U transmitters MUST meet the specifications defined in Table 60–8a of [802.3bk], with the exception of the Wavelength Range parameter.

D-ONU 2000BASE-PX30-U transmitters MUST meet the Wavelength Range specification defined in Table 9.

Table 9 - 2000BASE-PX30-D and 2000BASE-PX30-U Transmitter Characteristics

Parameter	2000BASE-PX30-D Transmitter	2000BASE-PX30-U Transmitter	Unit
Wavelength Range (Note 1)	1480 – 1500	1300 – 1320	nm
Note 1: Represents $\pm 1\sigma$ range of RMS spectral width central wavelength.			

A.2.1.4.2 Receiver Optical Specifications

DPoE System 2000BASE-PX30-U receivers MUST meet the specifications defined in Table 60–8c of [802.3bk], with the exception of the Wavelength Range parameter.

DPoE System 2000BASE-PX30-U receivers MUST meet the Wavelength Range specification defined in Table 10.

D-ONU 2000BASE-PX30-D receivers MUST meet the specifications defined in Table 60–8c of [802.3bk], with the exception of the Wavelength Range parameter.

D-ONU 2000BASE-PX30-D receivers MUST meet the Wavelength Range specification defined in Table 10.

Table 10 - 2000BASE-PX30-D and 2000BASE-PX30-U Receiver Characteristics

Description	2000BASE-PX30-D Receiver	2000BASE-PX30-U Receiver	Unit
Wavelength Range	1300 – 1320	1480 – 1500	nm

A.2.1.5 Transceiver PMD to MDI Optical Specifications for 2000BASE-PX40-D and 2000BASE-PX40-U

A.2.1.5.1 Transmitter Optical Specifications

DPoE System 2000BASE-PX40-D transmitters MUST meet the specifications defined in Table 60–8d of [802.3bk].

D-ONU 2000BASE-PX40-U transmitters MUST meet the specifications defined in Table 60–8d of [802.3bk].

A.2.1.5.2 Receiver Optical Specifications

DPoE System 2000BASE-PX40-U receivers MUST meet the specifications defined in Table 60–8e of [802.3bk], with the exception of the Wavelength Range parameter. DPoE System 2000BASE-PX40-U receivers MUST meet the Wavelength Range specification defined in Table 11.

D-ONU 2000BASE-PX40-D receivers MUST meet the specifications defined in Table 60–8e of [802.3bk], with the exception of the Wavelength Range parameter. D-ONU 2000BASE-PX40-D receivers MUST meet the Wavelength Range specification defined in Table 11.

Table 11 - 2000BASE-PX40-D and 2000BASE-PX40-U Receiver Characteristics

Description	2000BASE-PX40-D Receiver	2000BASE-PX40-U Receiver	Unit
Wavelength Range	1300 – 1320	1480 – 1500	nm

A.2.1.6 Receiver Wavelength Filtering

The minimum optical sensitivity of 2G-EPON receivers have to be met while interference signals exist. Interference signals are caused by other PON types or services such as video signals in the enhancement band. To minimize the effect of interference signals, 2G-EPON receivers need to isolate interference signals using an appropriate wavelength blocking filter (WBF) and WDM filter.

DPoE System 2000BASE-PX receivers SHOULD support filtering wavelength bands outside of the specified wavelength range, such that signals on other wavelengths do not cause any harmful interference to the reception of signals within the operating wavelength range.

D-ONU 2000BASE-PX receivers SHOULD support filtering wavelength bands outside of the specified wavelength range, such that signals on other wavelengths do not cause any harmful interference to the reception of signals within the operating wavelength range.

It is expected that 36 dB of optical isolation will be required to meet this requirement.

A.2.1.7 Transceiver Jitter at TP1 to TP4 (Reference Definition)

The high-frequency jitter and the jitter transfer function for the 2000BASE-PX transceiver is defined in Clause 60.6 of [802.3bk]. The 2000BASE-PX test points match those of 1000BASE-PX, illustrated in Figure 60-2 of [802.3].

A.2.1.8 PMD sublayer service interface

The PMD Sublayer Service Interface is defined in Clause 60 of [802.3]. Note that for 2G-EPON, the PMA sends the stream of bits to the PMD at the nominal rate of either 2.5 Gbd or 1.25 Gbd, depending upon the mode of operation.

A.2.1.9 PMD Delay Constraints

PMD delay constraints are defined in [802.3].

A.2.2 PMA Sublayer

The 2G-EPON system PMA sublayer is similar to 1G-EPON system and mainly implements the following functions:

1. Map the codes from or to the PCS sublayer and the signal definition to the DTBI definition;
2. Either implement serial/parallel conversion for codes and forward them to the PMD sublayer or implement serial/parallel conversion for received codes from PMD sublayer.
3. Recover clock from 8B/10B code the from PMD sublayer.
4. Map bit stream from/to the PMD sublayer.
5. Support implementing data loopback at the PMD service interface.

The clock frequency used by the PMA sublayer is 125 MHz, and when the 2G-EPON system works in 2 Gbps mode, the downstream rate between the PMA sublayer and the PMD sublayer is 2.5 Gbps. When the 2G-EPON system works in 1 Gbps mode, the downstream rate between the PMA sublayer and the PMD sublayer is 1.25 Gbps.

A.2.3 PCS Sublayer

The 2G-EPON system uses a PCS sublayer that is similar to the 1G-EPON system. When the 2G-EPON system is in downstream 1.25 Gbps rate mode, it uses the same 8B/10B coding as the 1G-EPON system. When the 2G-EPON system is in downstream 2 Gbps rate mode, the bus bit width is 16 bit, using double 8B/10B coding (i.e. low 8-bit and high 8-bit respectively use 8B/10B coding independently). The 2G-EPON DPoE system MUST support the FEC codec function. A DPoE System that supports 2G-EPON SHOULD be able to enable/disable FEC functions based on the ONU.

The FEC function of a DPoE System that supports 2G-EPON SHOULD meet the FEC coding requirement specified in [802.3].

A.2.4 RS Sublayer

The 2G-EPON system uses the same RS sublayer as the 1G-EPON system. Refer to the 1G-EPON system requirements in [802.3] for further details.

A.2.5 OAM Sublayer

A DPoE System that supports 2G-EPON MUST support the EPON Mode (D7/00 14) OAM message per [DPoE-SP-OAMv1.0].

A D-ONU that supports 2G-EPON MUST support the EPON Mode (D7/00 14) OAM message per [DPoE-SP-OAMv1.0].

A.2.6 Multipoint MAC Control (MPMC) Sublayer

The MPMC sublayer uses MPCP and defines the P2MP optical network MAC control mechanism.

Appendix I Acknowledgments

On behalf of our industry, we would like to thank the following individuals for their contributions to the development of this specification.

Contributor	Company Affiliation
John Dickinson	Bright House Networks
Andrew Chagnon, Drew Davis, James Fletcher, Paul Gray	Broadcom
Mike Holmes	Broadway Networks
Curtis Knittle, Bob Lund, Glenn Russell	CableLabs
Shamim Akhtar, Doug Jones, Mehmet Toy	Comcast
Vladimir Bronstein, James Chen, Hesham ElBakoury	Hitachi Communication Technologies America
Victor Blake	Independent Consultant
Robert Harris, Karen Rice, Ashish Sardesai	Time Warner Cable
Marek Hajduczenia, Nevin Jones, Zang Meiyang	ZTE

In addition to the above, we would like to thank the following individuals who provided subject matter expertise on one or more aspects of the project:

Contributor	Company Affiliation
Edwin Mallette	Bright House Networks
Andrew Dellow, Niki Pantelias, Ricki Li, Paul Runcy, Ed Boyd, Howard Abramson, Matt Hartling	Broadcom
Jianhui Zhou, Wen Li, Fulin Pan	Broadway Networks
Brian Hedstrom, Stuart Hoggan, Greg White, Karthik Sundaresan, Chris Donley	CableLabs
Jason Combs, Saif Rahman, Matt Scully, Bin Wen, Philip Chang, Rashid Siddiqui	Comcast
Dylan Ko, Simon Zhu, Guru Yeleswarapu, Jeff Stribling	Hitachi
Ron daSilva, Mike Kelsen, Shan Huang, Matt Cannon, Tushar Nakhre	Time Warner Cable
Stove Li Zhang, David Chen, Dick Chen	ZTE

Appendix II Revision History

II.1 Engineering Change for DPoE-SP-PHYv1.0-I02-120830

ECN	Date Accepted	Summary	Author
PHYv1.0-12.0037-1	06/21/12	Changes to FEC disable requirements for 10G-EPON	Marek Hajduczenia

II.2 Engineering Change for DPoE-SP-PHYv1.0-I03-130328

ECN	Date Accepted	Summary	Author
PHYv1.0-12.0054-1	11/29/12	Removal of optional requirement for 10G-EPON FEC	Marek Hajduczenia

II.3 Engineering Change for DPoE-SP-PHYv1.0-I04-140327

CN	Date Accepted	Summary	Author
PHYv1.0 -N-14.0121-1	02/27/2014	Support for third party pluggable optics in DPoE System	Marek Hajduczenia

II.4 Engineering Changes for DPoE-SP-PHYv1.0-I05-140807

ECN	Date Accepted	Summary	Author
PHYv1.0-N-14.0160-1	7/3/2014	Alignment and cleanup of 802.3 references	Marek Hajduczenia
PHYv1.0-N-14.0184-1	7/10/2014	DPoEv1 PHY Edits to Support 2G-EPON	Joe Solomon
