

Data-Over-Cable Service Interface Specifications

DCA - MHA v2

Remote Out-of-Band Specification

CM-SP-R-OOB-I02-160121

ISSUED

Notice

This DOCSIS® specification is the result of a cooperative effort undertaken at the direction of Cable Television Laboratories, Inc. for the benefit of the cable industry and its customers. You may download, copy, distribute, and reference the documents herein only for the purpose of developing products or services in accordance with such documents, and educational use. Except as granted by CableLabs® in a separate written license agreement, no license is granted to modify the documents herein (except via the Engineering Change process), or to use, copy, modify or distribute the documents for any other purpose.

This document may contain references to other documents not owned or controlled by CableLabs. Use and understanding of this document may require access to such other documents. Designing, manufacturing, distributing, using, selling, or servicing products, or providing services, based on this document may require intellectual property licenses from third parties for technology referenced in this document. To the extent this document contains or refers to documents of third parties, you agree to abide by the terms of any licenses associated with such third-party documents, including open source licenses, if any.

© Cable Television Laboratories, Inc., 2014-2016

DISCLAIMER

This document is furnished on an "AS IS" basis and neither CableLabs nor its members provides any representation or warranty, express or implied, regarding the accuracy, completeness, noninfringement, or fitness for a particular purpose of this document, or any document referenced herein. Any use or reliance on the information or opinion in this document is at the risk of the user, and CableLabs and its members shall not be liable for any damage or injury incurred by any person arising out of the completeness, accuracy, or utility of any information or opinion contained in the document.

CableLabs reserves the right to revise this document for any reason including, but not limited to, changes in laws, regulations, or standards promulgated by various entities, technology advances, or changes in equipment design, manufacturing techniques, or operating procedures described, or referred to, herein.

This document is not to be construed to suggest that any company modify or change any of its products or procedures, nor does this document represent a commitment by CableLabs or any of its members to purchase any product whether or not it meets the characteristics described in the document. Unless granted in a separate written agreement from CableLabs, nothing contained herein shall be construed to confer any license or right to any intellectual property. This document is not to be construed as an endorsement of any product or company or as the adoption or promulgation of any guidelines, standards, or recommendations.

Document Status Sheet

Document Control Number:	CM-SP-R-OOB-I02-160121			
Document Title:	Remote Out-of-Band Specification			
Revision History:	I01 - Released 06/15/2015 I02 - Released 01/21/2016			
Date:	January 21, 2016			
Status:	Work in Progress	Draft	Issued	Closed
Distribution Restrictions:	Author Only	CL/Member	CL/Member/Vendor	Public

Key to Document Status Codes

Work in Progress	An incomplete document designed to guide discussion and generate feedback, and may include several alternative solutions for consideration.
Draft	A document in Specification format considered largely complete, but lacking review by Members and Technology Suppliers. Drafts are susceptible to substantial change during the review process.
Issued	A generally public document that has undergone Member and Technology Supplier review, cross-vendor interoperability, and is available for Certification testing. Issued Specifications are subject to the Engineering Change (EC) Process.
Closed	A static document, reviewed, tested, validated, and closed to further ECs.

Trademarks

CableLabs® is a registered trademark of Cable Television Laboratories, Inc. Other CableLabs marks are listed at <http://www.cablelabs.com/certqual/trademarks>. All other marks are the property of their respective owners.

Table of Contents

1	SCOPE	7
1.1	Introduction and Purpose.....	7
1.2	MHAv2 Interface Documents.....	7
1.3	Requirements and Conventions.....	8
2	REFERENCES	9
2.1	Normative References.....	9
2.2	Informative References.....	9
2.3	Reference Acquisition.....	10
3	TERMS AND DEFINITIONS	11
4	ABBREVIATIONS AND ACRONYMS	13
5	OVERVIEW	15
6	R-OOB REMOTE PHY ARCHITECTURE	16
6.1	[SCTE 55-2] Remote PHY Solution (Informative).....	16
6.1.1	Conventions.....	17
6.1.2	SCTE 55-2 Network Requirements (Normative).....	17
6.1.3	SCTE 55-2 R-OOB Data Path.....	18
6.1.4	RPD System Implementation Overview (Informative).....	26
6.1.5	RPD System Implementation Requirements (Normative).....	27
6.1.6	RPD 55-2 Signal Processing Requirements.....	30
6.2	[SCTE 55-1] Remote PHY Solution.....	34
6.2.1	Forward Path.....	35
6.2.2	Return Path.....	37
6.2.3	System Timing Considerations.....	42
7	R-OOB NARROWBAND ARCHITECTURE	43
7.1	Remote PHY Narrowband Digital Forward (NDF).....	44
7.1.1	Overview.....	44
7.1.2	NDF Channel Definition.....	44
7.1.3	NDF Channel Rate.....	45
7.1.4	NDF Signal Processing Requirements.....	45
7.2	Remote PHY Narrowband Digital Return (NDR).....	46
7.2.1	Overview.....	46
7.2.2	NDR Channel Definition.....	46
7.2.3	NDR Channel Rate.....	47
7.2.4	NDR Signal Processing Requirements.....	47
7.3	NDR/NDF Power Level and Digital Sample Representation.....	48
7.4	NDF/NDR Power Level Range and Performance Requirements.....	48
7.5	Networking Considerations.....	48
7.6	System Timing Considerations.....	49
APPENDIX I	SCTE 55-1 OOB SYSTEM NOTES (INFORMATIVE)	50
I.1	OOB Delivery Overview.....	50
I.1.1	OOB Delivery in Headends Today.....	50
I.2	SCTE 55-1 OOB System Components.....	51
APPENDIX II	SCTE 55-2 SYSTEM NOTES (INFORMATIVE)	52
APPENDIX III	ACKNOWLEDGEMENTS	54
APPENDIX IV	REVISION HISTORY	56

IV.1 Engineering Changes for CM-SP-R-OOB-I02-160121	56
---	----

List of Figures

Figure 1- 55-2 Remote PHY Solution	17
Figure 2 - SCTE 55-2 Downstream Packet Format	19
Figure 3 - SCTE 55-2 Upstream Packet Format	22
Figure 4 - SCTE 55-2 R-PHY Function Segmentation.....	26
Figure 5 - ATM IDLE Cell Format	31
Figure 6 - Slot Allocation Processor.....	31
Figure 7 - OM as a Multiplexer	35
Figure 8 - Unique OOB Delivery to Multiple Sets of RPDs	36
Figure 9 - SCTE 55-1 Remote PHY Implementation	37
Figure 10 - Legacy System	38
Figure 11 - Remote PHY System with Virtual ARPDs	39
Figure 12 - Example Virtual ARPD/Remote PHY Device distribution	40
Figure 13 - UEPI SCTE 55-1 Packet Format.....	41
Figure 14 - CCAP Core to Network Controller Packet Format	41
Figure 15 - NDF/NDR OOB Network Topology	43
Figure 16 - PSP OOB Header Format	45
Figure 17 - PSP OOB Header Format	47
Figure 18 - Traditional OOB Transmission.....	51
Figure 19 - Legacy SCTE 55-2 System Deployment Architecture.....	53

List of Tables

Table 1 - Downstream Tunnel Header Field Description	20
Table 2 - L2TPv3 Header Description.....	20
Table 3 - L2TPv3 DEPI 55-2 Sublayer Header Description.....	20
Table 4 - Downstream SCTE 55-2 OOB Header Field Description	20
Table 5 - Downstream SCTE 55-2 OOB ATM Cell Field Description	21
Table 6 - Downstream SCTE 55-2 OOB Slot Allocation Field Description	21
Table 7 - Upstream Tunnel Header Field Description	23
Table 8 - L2TPv3 Header Description.....	23
Table 9 - L2TPv3 DEPI 55-2 Sublayer Header Description.....	23
Table 10 - Upstream SCTE 55-2 OOB Header Field Description.....	23
Table 11 - Upstream SCTE 55-2 OOB ATM Cell Field Description.....	24
Table 12 - RPD Read-Only Settings.....	27
Table 13 - RPD Configurable Settings	28
Table 14 - Per Modulator Configurable Settings	28
Table 15 - Per Demodulator Configurable Settings.....	29
Table 16 - Distance to Time Offset Conversion	30

Table 17 - RS Decode Status Field.....	33
Table 18 - Upstream Slot Start and End Times	34
Table 19 - Header Format for SCTE 55-1 sublayer Header and Payload.....	41
Table 20 - Common Forward OOB Signals	44
Table 21 - NDF Channel Parameters.....	44
Table 22 - Common Return OOB Signals	46
Table 23 - NDR Channel Parameters	46

1 SCOPE

1.1 Introduction and Purpose

Digital (MPEG transport) video delivery in traditional HFC distribution networks has utilized a unique two-way physical layer signaling as a core requirement. Two standards were widely deployed and are described in references [SCTE 55-1] and [SCTE 55-2]. These two signaling systems have been deployed en masse in parallel with digital MPEG Video transport.

Millions of deployed STBs remain dependent upon this legacy 2-way communication framework for localization, video control/enablement data delivery, code upgrades, and two-way interactive applications. Other devices, such as cable-ready TVs rely on this data to for program location and emergency alert notifications. DOCSIS Set-top Gateway [DSG] has been developed and fielded as an alternative delivery mechanism for the same data, however the physical OOB signaling remains a "MUST" to support for the aforementioned reasons.

1.2 MHA v2 Interface Documents

A list of the documents in the MHA v2 family of specifications is provided below. For updates, refer to <http://www.cablelabs.com/specs/specification-search/>.

Designation	Title
CM-SP-R-PHY	Remote PHY Specification
CM-SP-R-DEPI	Remote Downstream External PHY Interface Specification
CM-SP-R-UEPI	Remote Upstream External PHY Interface Specification
CM-SP-R-GCP	Generic Control Plane Specification
CM-SP-R-DTI	Remote DOCSIS Timing Interface Specification
CM-SP-R-OOB	Remote Out-of-Band Specification
CM-SP-R-OSSI	Remote PHY OSS Interface Specification

NOTE: MHA v2 does not explicitly use any of the original Modular Headend Architecture specifications.

1.3 Requirements and Conventions

Throughout this document, the words that are used to define the significance of particular requirements are capitalized. These words are:

- | | |
|--------------|---|
| "MUST" | This word means that the item is an absolute requirement of this specification. |
| "MUST NOT" | This phrase means that the item is an absolute prohibition of this specification |
| "SHOULD" | This word means that there may exist valid reasons in particular circumstances to ignore this item, but the full implications should be understood and the case carefully weighed before choosing a different course. |
| "SHOULD NOT" | This phrase means that there may exist valid reasons in particular circumstances when the listed behavior is acceptable or even useful, but the full implications should be understood and the case carefully weighed before implementing any behavior described with this label. |
| "MAY" | This word means that this item is truly optional. One vendor may choose to include the item because a particular marketplace requires it or because it enhances the product, for example; another vendor may omit the same item. |

2 REFERENCES

At the time of publication, the editions indicated were valid. All references are subject to revision, and users of this document are encouraged to investigate the possibility of applying the most recent editions of the documents listed below. References are either specific (identified by date of publication, edition number, version number, etc.) or non-specific. For a nonspecific reference, the latest version applies.

2.1 Normative References¹

In order to claim compliance with this specification, it is necessary to conform to the following standards and other works as indicated, in addition to the other requirements of this specification. Notwithstanding, intellectual property rights may be required to use or implement such normative references.

- [ARPD] Advanced Return Path Demodulator (ARPD) Interface Protocol, Revision x.1, 8/10/2015. For details on obtaining this document and the concomitant ARPD MIB contact Jorge Salinger, VP Access Architecture, Comcast, jorge_salinger@cable.comcast.com
- [DEPI] Downstream External PHY Interface Specification, CM-SP-DEPI-I08-100611, June 11, 2010, Cable Television Laboratories, Inc.
- [DSG] DOCSIS Set-top Gateway, CM-SP-DSG-I24-130808, August 8, 2013, Cable Television Laboratories, Inc.
- [R-DEPI] Remote Downstream External PHY Interface Specification, CM-SP-R-DEPI-I03-160121, January 21, 2016, Cable Television Laboratories, Inc.
- [R-DTI] Remote DOCSIS Timing Interface, CM-SP-R-DTI-I02-151001, October 1, 2015, Cable Television Laboratories, Inc.
- [RFC 2684] IETF RFC 2684, Multiprotocol Encapsulation over ATM Adaptation Layer 5, September 1999.
- [RFC 3931] IETF RFC 3931, Layer Two Tunneling Protocol - Version 3 (Layer 2TPv3), March 2005.
- [RFC 5085] IETF RFC 5085, Pseudowire Virtual Circuit Connectivity Verification (VCCV): A Control Channel for Pseudowires, T. Nadeau, C. Pignataro, December 2007
- [R-PHY] Remote PHY System Specification, CM-SP-R-PHY-I03-160121, January 21, 2016, Cable Television Laboratories, Inc.
- [R-UEPI] Remote Upstream External PHY Interface Specification, CM-SP-R-UEPI-I02-160121, January 21, 2016, Cable Television Laboratories, Inc.
- [SCTE 55-1] ANSI SCTE 55-1 2009, Digital Broadband Delivery System: Out of Band Transport Part 1: Mode A.
- [SCTE 55-2] ANSI/SCTE 55-2 2008, Digital Broadband Delivery System: Out of Band Transport Part 2: Mode B.

2.2 Informative References

This document uses the following informative references:

- [IEEE 802.3] IEEE Std 802.3TM-2002, Part 3: Carrier Sense Multiple Access With Collision Detection (CSMA/CD) Access Method and Physical Layer Specifications, March 2002.
- [SCTE 18] CEA/SCTE 18 2013, Emergency Alert Messaging for Cable.

¹ Revised per R-00B-N-15.1399-3 on 1/8/15 by JB.

2.3 Reference Acquisition

- European Telecommunications Standards Institute, ETSI, <http://www.etsi.org>
- The Institute of Electrical and Electronics Engineers, Inc., Internet: <http://standards.ieee.org>
- International Telecommunications Union, Telecommunications Sector, <http://www.itu-t.org/>
- Internet Engineering Task Force (IETF), Internet: <http://www.ietf.org>
- Internet Assigned Numbers Authority, IANA, Internet: <http://www.iana.org>
- Society of Cable Telecommunications Engineers (SCTE) Standards, <http://www.scte.org>

3 TERMS AND DEFINITIONS

This specification uses the following terms:

Cable Modem (CM)	A modulator-demodulator at subscriber locations intended for use in conveying data communications on a cable television system.
Converged Interconnect Network	The network (generally gigabit Ethernet) that connects a CCAP Core to an EQAM.
Customer Premises Equipment (CPE)	Equipment at the end user's premises; may be provided by the service provider.
Data Rate	Throughput, data transmitted in units of time usually in bits per second (bps).
Decibels (dB)	Ratio of two power levels expressed mathematically as $\text{dB} = 10\log_{10}(P_{\text{OUT}}/P_{\text{IN}})$.
Decibel-Millivolt (dBmV)	Unit of RF power expressed in decibels relative to 1 millivolt, where $\text{dBmV} = 20\log_{10}(\text{value in mV}/1 \text{ mV})$.
Downstream (DS)	<ol style="list-style-type: none"> 1. Transmissions from CMTS to RPD. This includes transmission from the CCAP Core to the EQAM, as well as the RF transmissions from the EQAM to the RPD. 2. RF spectrum used to transmit signals from a cable operator's headend or hub site to subscriber locations.
Edge QAM modulator (EQAM)	A headend or hub device that receives packets of digital video or data. It re-packetizes the video or data into an MPEG transport stream and digitally modulates the digital transport stream onto a downstream RF carrier using quadrature amplitude modulation (QAM).
Flow	A stream of packets in [DEPI] used to transport data of a certain priority from the CCAP Core to a particular QAM channel of the EQAM. In PSP operation, there can exist several flows per QAM channel.
Gbps	Gigabits per second
Gigahertz (GHz)	A unit of frequency; 1,000,000,000 or 10^9 Hz.
GigE (GE)	Gigabit Ethernet (1 Gbps)
Hertz (Hz)	A unit of frequency; formerly cycles per second.
Hybrid Fiber/Coax (HFC) System	A broadband bidirectional shared-media transmission system using optical fiber trunks between the headend and the fiber nodes, and coaxial cable distribution from the fiber nodes to the customer locations.
Institute of Electrical and Electronic Engineers (IEEE)	A voluntary organization which, among other things, sponsors standards committees and is accredited by the American National Standards Institute (ANSI).
Internet Engineering Task Force (IETF)	A body responsible for, among other things, developing standards used in the Internet.
Internet Protocol (IP)	An Internet network-layer protocol
kilohertz (kHz)	Unit of frequency; 1,000 or 10^3 Hz; formerly kilocycles per second
Link Rate	Total effective throughput, i.e., data transmitted in units of time usually in symbols per second (Sps).
MAC Domain	A grouping of Layer 2 devices that can communicate with each other without using bridging or routing. In DOCSIS is the group of CMs that are using upstream and downstream channels linked together through a MAC forwarding entity.

Maximum Transmission Unit (MTU)	Maximum size of the Layer 3 payload of a Layer 2 frame.
Mbps	Megabits per second
Media Access Control (MAC)	Used to refer to the Layer 2 element of the system which would include DOCSIS framing and signaling.
Megahertz (MHz)	A unit of frequency; 1,000,000 or 10 ⁶ Hz; formerly megacycles per second
Microsecond (μs)	10 ⁻⁶ second
Millisecond (ms)	10 ⁻³ second
Modulation Error Ratio (MER)	The ratio of the average symbol power to average error power
Multiple System Operator (MSO)	A corporate entity that owns and/or operates more than one cable system.
Nanosecond (ns)	10 ⁻⁹ second
Physical Media Dependent (PMD) Sublayer	A sublayer of the Physical layer which is concerned with transmitting bits or groups of bits over particular types of transmission link between open systems and which entails electrical, mechanical, and handshaking procedures.
QAM channel (QAM ch)	Analog RF channel that uses quadrature amplitude modulation (QAM) to convey information
Quadrature Amplitude Modulation (QAM)	A modulation technique in which an analog signal's amplitude and phase vary to convey information, such as digital data.
Radio Frequency (RF)	In cable television systems, this refers to electromagnetic signals in the range 5 to 1000 MHz.
Radio Frequency Interface	Term encompassing the downstream and the upstream radio frequency interfaces.
Upconverter	A device used to change the frequency range of an analog signal, usually converting from a local oscillator frequency to an RF transmission frequency.
Upstream (US)	<ol style="list-style-type: none"> 1. Transmissions from CM to CMTS. This includes transmission from the RPD to the CCAP Core as well as the RF transmissions from the CM to the CCAP Core. 2. RF spectrum used to transmit signals from a subscriber location to a cable operator's headend or hub site.
Upstream Channel Descriptor (UCD)	The MAC Management Message used to communicate the characteristics of the upstream physical layer to the cable modems.

4 ABBREVIATIONS AND ACRONYMS

This specification uses the following abbreviations:

μsec, μsecond	Microsecond (10 ⁻⁶ second)
AAL 5 SAR	ATM Adaptation Layer 5 Segmentation and Reassembly
AM	Amplitude Modulation
CA	Conditional Access
CCAP	Converged Cable Access Platform
CDL	Common Download
CIN	Converged Interconnect Network
CMTS	Cable Modem Termination System
CPE	Customer Premise Equipment
DAC	Digital Addressable Controller
DCA	Distributed CCAP Architecture
DEPI	Downstream External PHY Interface
DHCT	Digital Home Communications Terminal
DOCSIS	Data-Over-Cable Service Interface Specifications
DS	Downstream
DSG	DOCSIS Set-top Gateway
DSP	Digital Signal Processing
DTI	DOCSIS Timing Interface
EAS	Emergency Alert System
EMM	Entitlement Management Message
EQAM	Edge QAM
FIFO	First In, First Out (buffer)
FM	Frequency Modulation
HE	Headend
HFC	Hybrid Fiber Coax
IEEE	Institute of Electrical and Electronic Engineers
IETF	Internet Engineering Task Force
IGMP	Internet Group Management Protocol
IP	Internet Protocol
I/Q	In-phase Quadrature (Used to denote the complex RF data format)
kHz	Kilohertz
LFG	Live Feed Generator
MAC	Media Access Control
MHz	Megahertz
MPEG	Moving Picture Experts Group
MTU	Maximum Transmission Unit
NC	Network Controller
NDF	Narrowband Digital Forward

NDR	Narrowband Digital Return
NIT	Network Information Table
OAM&P	Operations, Administration, Maintenance, & Provisioning
OM	Out-of-Band Modulator
OOB	Out-of-Band
PAT	Program Association Table
PHY	Physical Layer
PID	Packet Identifier
PMT	Program Map Table
PSP	Packet Streaming Protocol
PW	Pseudowire
QAM	Quadrature Amplitude Modulation
QPSK	Quadrature Phase Shift Keying
RADD	Remotely Addressable DANIS and DLS
RCVR	Receive Module
RF	Radio Frequency
RPD	1) Remote PHY Device or 2) Return Path Demodulator
SC-QAM	Single Carrier Quadrature Amplitude Modulation
S, G	Source (unicast) Address and Group (Multicast) Address
STB	Set-top Box
TDMA	Time Division Multiple Access
UDP	User Datagram Protocol
UEPI	Upstream External PHY Interface
VCI	Virtual Channel Identifier
VLAN	Virtual Local Area Network
VPI	Virtual Path Identifier
WAN	Wide Area Network
XMIT	(Transmit) Forward Lasers

5 OVERVIEW

Multiple approaches to passing OOB signals through a Remote PHY Device (RPD) will be specified. Each approach differs in the functionality hosted on the CCAP Core, constraints/capacities/demands placed on the CIN, and functionality placed in the RPD.

The [SCTE 55-1] and [SCTE 55-2] systems are fundamentally different in that the SCTE 55-2 system includes a scheduled TDMA upstream that is intolerant of packet network latency/jitter and does not include provisions of equivalent "map advance" DOCSIS features to compensate. The SCTE 55-1 system does not include such upstream scheduling capabilities (and timing/jitter constraints), however requires multiple upstream frequencies to operate. For reference, the legacy SCTE 55-1 and SCTE 55-2 system solutions are detailed in Appendix I and Appendix II respectively.

Three approaches for passing OOB signals are specified in this document as follows:

- SCTE 55-2 Remote PHY solution (detailed in Section 6.1) serves to replace the existing SCTE 55-2 modulator/demodulator hardware and RF combining circuitry deployed in legacy headends with small-scale SCTE 55-2 modulator/demodulator functions embedded in each RPD. The high-level MAC functionality resides in an external server.
- SCTE 55-1 Remote PHY solution (detailed in Section 6.2) serves to utilize existing SCTE 55-1 modulator functionality (packet based output instead of RF output) in the downstream, and place upstream demodulator and reassembly functions in the RPD.
- Narrowband Digital Forward (NDF) and Narrowband Digital Return (NDR) digitizes a small portion of the spectrum, and sends the digital samples as payload within packets which traverse between the CMTS and the RPD. This approach works with any type of OOB signal as long as the signal can be contained within the defined pass bands. This approach is detailed in Section 7.

The SCTE 55-2 Remote PHY and SCTE 55-1 Remote PHY solutions are targeted specifically at supporting legacy Set-top Box (STB) equipment that employs either [SCTE 55-1] or [SCTE 55-2] PHY layer signaling. This approach requires that the RPD has specific knowledge of the protocols such that it can de-modulate/modulate the OOB data, and perform some portion of the MAC layer processing of this data.

6 R-OOB REMOTE PHY ARCHITECTURE

6.1 [SCTE 55-2] Remote PHY Solution (Informative)²

All of the requirements in this section only apply to devices that implement SCTE 55-2.

The SCTE 55-2 R-OOB MHA_v2/ Remote PHY architecture is best understood through examination and comparison to existing system deployments. Appendix II contains a reference overview of the existing 55-2 system deployment.

Figure 1 depicts a deployment environment supporting 55-2 in a Remote PHY architecture.

In the video headend, 55-2 apps and services remain exactly as in existing 55-2 system deployments. The 55-2 Controller element within the video headend maintains all interfaces with those existing apps and services but contains only a subset of the functionality of the existing 55-2 Mod/Demod. The remaining functionality of the 55-2 Mod/Demod is shifted to the RPD.

55-2 requires fast turnaround from receipt of an ATM cell to acknowledging receipt of that cell. Implementing this slot receipt acknowledgement in the 55-2 Controller imposes undesirable constraints on the CIN (sub-1ms 55-2 Controller to RPD one-way latency). The SL-ESF Frame Schedules are also constrained by the fast turnaround since the Frame Schedules host the receipt acknowledgement bits. Frame Schedules can be pre-generated outside the RPD but the mechanism to deliver them needs to be present in the RPD. The SCTE 55-2 Remote PHY solution places components necessary for performing ATM slot receipt acknowledgement within the RPD, and all other components of the SCTE 55-2 MAC (including AAL5 segmentation and reassembly) are located in the 55-2 Controller where feasible.

Configuration and monitoring of 55-2 specific functions within the RPD is handled by the 55-2 Controller acting as an Auxiliary CCAP Core associated with one or more Principal CCAP Cores which are responsible for global configuration items such as frequency settings and RF power levels. GCP is used as the transport protocol for all configuration and some monitoring traffic. Some monitoring is also included in the upstream data packets sent by the RPD to the 55-2 Controller.

To simplify system architecture and operation, all 55-2 traffic is tunneled directly between 55-2 Controller and RPD over the CIN without passing through the Principal CCAP Core. A multicast 55-2-specific L2TPv3 tunnel is used for downstream traffic with one or more unicast 55-2-specific L2TPv3 tunnels for upstream traffic.

RPD deployments are expected to serve a smaller number of homes passed per RPD than what is supported in the existing 55-2 Mod/Demod. Current 55-2 Digital Home Communication Terminal (DHCT) service group sizes are greater than 10,000 DHCTs, versus the expected RPD DHCT counts which can be 1000 or lower. For compatibility with existing infrastructure, RPDs are grouped with a single 55-2 Controller as follows:

- Multiple RPDs are bound by operator configuration to a single 55-2 Controller which can service >10,000 DHCTs.
- RPD demodulators are assigned an Upstream Group ID between 0 and 7. All demodulators in the same Upstream Group logically-share the same upstream slot assignments for 55-2 compatibility. Upstream Group ID is equivalent to SCTE 55-2 Demodulator Number, but is zero indexed instead of 1 indexed. Upstream Group ID 0 corresponds to SCTE 55-2 Demodulator Number 1 (R1), Upstream Group ID 7 corresponds to SCTE 55-2 Demodulator Number 8 (R8).
- All RPDs bound to a single 55-2 Controller share a single L2TPv3 multicast tunnel for downstream data.

² All of Section 6.1 and its subsections replaced by R-OOB-N-15.1402-2 on 1/8/2016 by JB.

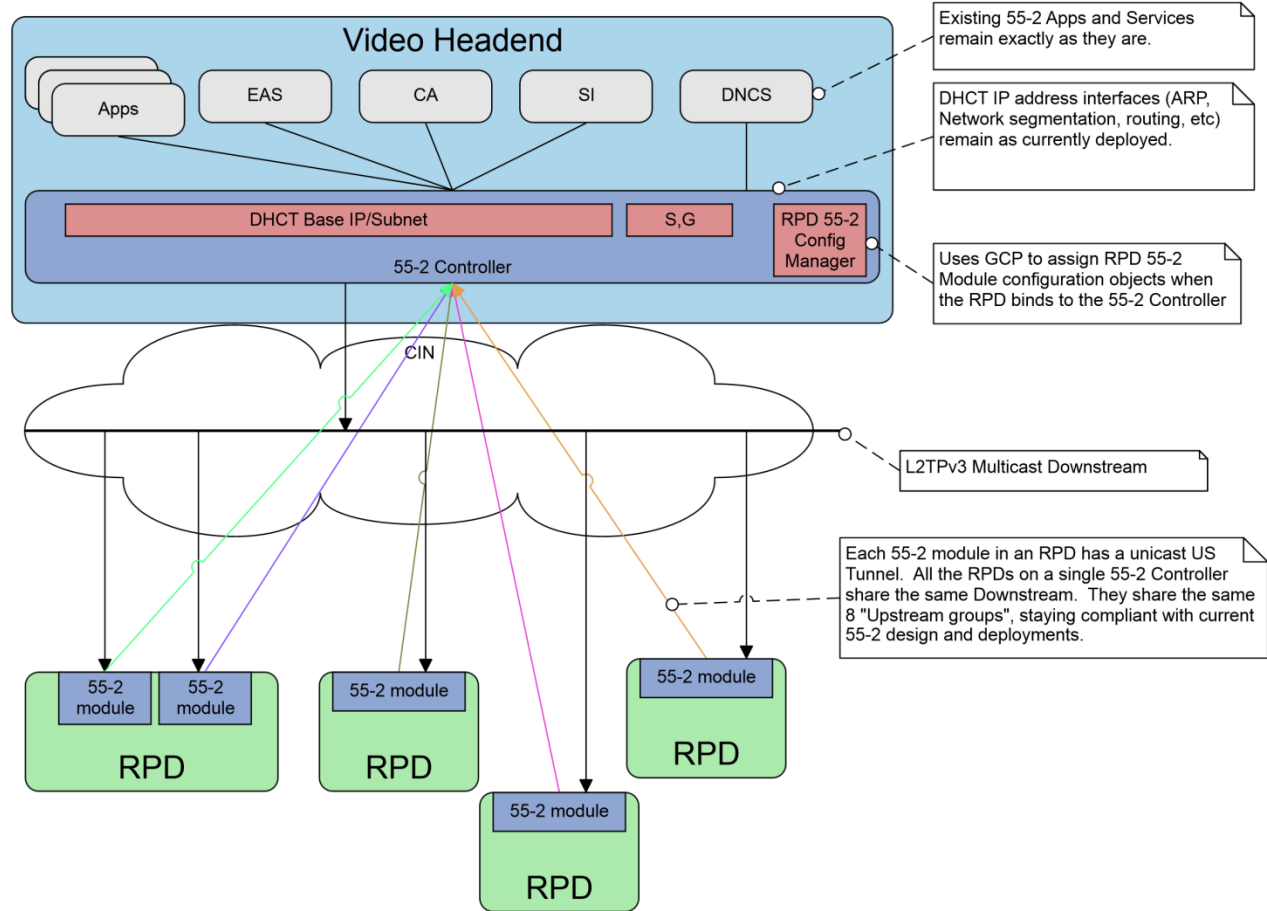

Figure 1- 55-2 Remote PHY Solution

6.1.1 Conventions

Within Section 6.1, Any time a bit field is displayed in a figure, it should be interpreted by reading the figure from left to right, then from top to bottom, with the MSB being the first bit so read and the LSB being the last bit so read. Any time a multi-byte word is represented, the same convention applies, with the most significant byte being the one at the top left, with bytes decreasing in significance from left to right, and then from top to bottom.

6.1.2 SCTE 55-2 Network Requirements (Normative)

6.1.2.1 RPD Network Requirements

- The RPD **MUST** connect to only one 55-2 Controller.
- The RPD **MUST** support reception of 55-2 specific L2TPv3 multicast packets containing downstream ATM cells and metadata.
- The RPD **MUST** support 55-2 specific IP and L2TPv3 Encapsulation of upstream ATM cells and metadata.
- The RPD **MUST** support sending at least one L2TPv3 upstream tunnel per RPD to the 55-2 Controller.
- The RPD **MAY** support sending additional L2TPv3 upstream tunnels (up to one tunnel per SCTE 55-2 demodulator on the RPD).
- The RPD **MAY** support sending upstream data from up to 8 demodulators on a single upstream tunnel.
- The RPD **MUST** support forwarding of IP unicast packets to the 55-2 Controller.

- The RPD MUST support GCP configuration by the 55-2 Controller using authenticated and secured connections.
- The RPD MUST support an authenticated and secured L2TPv3 control connection with the 55-2 Controller as described in section 6.6.2.1 of [R-PHY].

6.1.3 SCTE 55-2 R-OOB Data Path

The SCTE 55-2 R-OOB data path relies on tunneling to isolate the OOB traffic from the DOCSIS and MPEG Video traffic. The expected capacity of each of the downstream and upstream tunnels (one upstream tunnel per RPD 55-2 demodulator and one multicast downstream tunnel for each 55-2 Controller) are aligned with the capacity of the 55-2 link – 1.544 Mbps ESF rate corresponding to Grade A downstream and Grade B upstream as per [SCTE 55-2].

SCTE 55-2 OOB Data Plane packets do not use a L2-Specific Sublayer header as all necessary metadata is contained in the header of the encapsulated payload.

6.1.3.1 Downstream

The RPD MUST include a buffer of at least 6 kilobytes per downstream channel for downstream ATM cells to support 10ms of network jitter.

The 55-2 Controller will generate future slot allocation assignments - how far into the future depends on latency of the network connecting the 55-2 Controller to the worst-case RPD.

The RPD MUST include at least 256 bytes per downstream channel of slot allocation buffer to support 10ms of network jitter.

The 55-2 Controller MAY provide up to 15 slot allocation assignments in a single downstream message.

The RPD MUST support 55-2 operation independent of whether the RPD and 55-2 Controller timing is synchronized to a common PTP clock master.

RPDs MUST send their current available buffer space in each upstream message in order to support system operation without timing synchronization between 55-2 Controller and RPD. If synchronization is not present, some RPDs will consume data and transmit ESFs at slightly higher rates than others. The 55-2 Controller will track the available buffer space of its connected RPDs and send data and slot assignments to all RPDs based on the processing rate of the slowest RPD.

The RPD MUST pad unassigned ATM slots with ATM IDLE cells in order to keep their DHCTs online while the slower RPDs catch up. For further information on timing considerations, see Section 6.1.5.3.

The structure of the downstream packet and headers is shown in Figure 2 below. Descriptions of each of the fields are contained in Table 1. An Ethernet 802.3 header and optional VLAN headers are in common with the DOCSIS and MPEG Video packet descriptions contained in [R-DEPI] and [R-UEPI]. The L2TPv3 header contains the Session ID which will (after control plane configuration) identify the payload as SCTE 55-2 OOB (see Section 6.1.5.2 for further information on Session establishment). The tunnel header is identical to the L2TPv3 tunnel header described in [R-DEPI].

The encapsulated payload is made up of the SCTE 55-2 OOB Downstream Header (including a re-sync frame number), from 0 to 10 ATM cells and from 0 to 15 slot schedules.

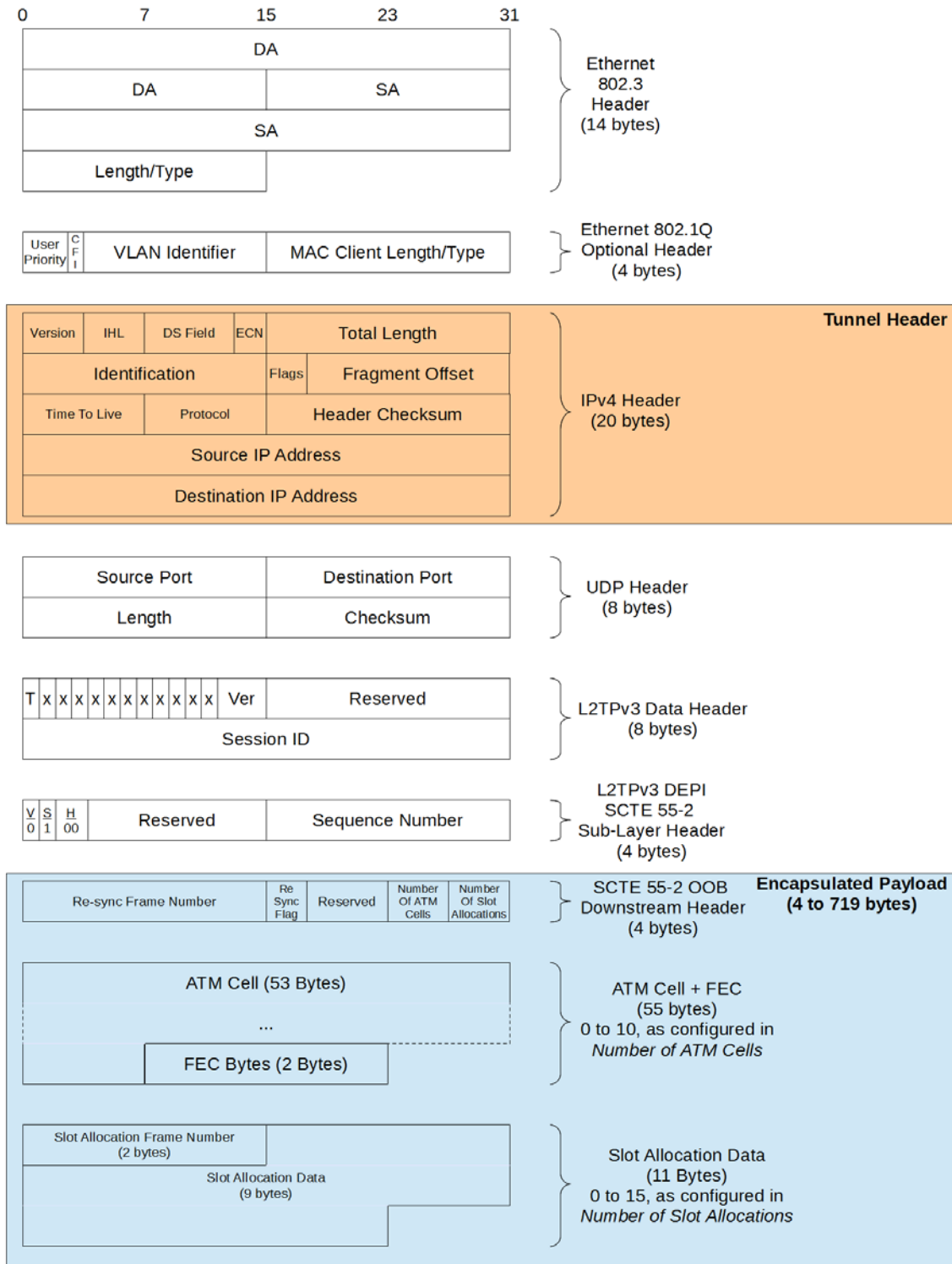

Figure 2 - SCTE 55-2 Downstream Packet Format

Descriptions of each field are contained in Table 1 through Table 6.

Table 1 - Downstream Tunnel Header Field Description

Field	Size (bits)	Description
Version	4	Always set to 4
IHL	4	The length of the outer IP header measured in 32-bit words
TOS	8	Copied from encapsulated payload header
Total Length	16	The Total Length measures the length of the entire encapsulated IP datagram, including the outer IP header, the inner IP header, and its payload.
Ident	16	Unique value for the tunnel header
Flags	3	R- unused DF – copied from encapsulated payload header MF- unused
Fragment Offset	13	Unused
TTL	8	Set to value appropriate to pass through the CIN.
Protocol	8	Set to 115
Header Checksum	16	IP Checksum of Tunnel Header
Source IP Addr	32	IP Address of the CCAP Tunnel entry point
Dest IP Addr	32	IP Address of the R-PHY Tunnel exit point

Table 2 - L2TPv3 Header Description

Field	Size (bits)	Description
T	1	Must be set to 0 to indicate data message.
x	1	Reserved, set to 0.
Ver	4	Must be set to 3 to indicate L2TPv3.
Reserved	16	Reserved, set to 0.
Session ID	32	Identifies the L2TPv3 Tunnel this packet belongs to.

Table 3 - L2TPv3 DEPI 55-2 Sublayer Header Description

Field	Size (bits)	Description
V	1	VCCV bit. Set to 0. Reserved for compatibility with [RFC 5085].
S	1	Sequence bit. Set to 1 to indicate that the sequence number field is valid. Set to 0 to indicate that the sequence field is not valid.
H	2	Extended Header Bits. Set to '00' to indicate a DEPI sublayer header that matches the current active pseudowire types.
Reserved	12	Reserved, set to 0.
Sequence Number	16	Sequence Number. The sequence number increments by one for each data packet sent, and may be used by the receiver to detect packet loss. The initial value of the sequence number SHOULD be random (unpredictable).

Table 4 - Downstream SCTE 55-2 OOB Header Field Description

Field	Size (bits)	Description
Re-Sync Frame Number	16	Frame number that the RPD should change its frame counter to if Re-Sync Flag is set.
Re-Sync Flag	1	Flag indicates RPD should resynchronize its frame number to re-sync frame number.
Reserved	7	Unused, set to 0.
Number of ATM Cells	4	Number of ATM cells contained in the message, from 0 to 10.
Number of Slot Allocations	4	Number of Slot Allocations contained in the message, from 0 to 15.

Table 5 - Downstream SCTE 55-2 OOB ATM Cell Field Description

Field	Size (bits)	Description
ATM Cell	424 (53 bytes)	Complete ATM cell.
FEC Bytes	16	Reed Solomon FEC Bytes for the ATM cell.

Table 6 - Downstream SCTE 55-2 OOB Slot Allocation Field Description

Field	Size (bits)	Description
Slot Allocation Frame number	16	ESF Number that the slot allocation is to go out on.
Slot Allocation Data		This is broken up into eight 9-bit subfields, for each of R1 to R8 in SCTE 55-2 section 2.1.9.
SL-ESF Framing Bits Subfield	8 x 9 bits	Each 9-bit subfield is broken up into the following bits (see SCTE 55-2 section 2.1.9 for definitions):
b0	1	Ranging control slot indicator
b1-b6	6	Slot boundary definition field
b16-b17	2	Reservation Control for next super frame

On receipt of an SCTE 55-2 Downstream Packet:

- If the Re-Sync Flag field is set to 1, the RPD MUST set its internal ESF counter to the value from the Re-Sync Frame Number field, and use that value as the ESF number in the next outgoing SL-ESF frame.
- If the Re-Sync Flag field is set to 1 the RPD MUST discard its entire Slot Allocation buffer.
- If this is the first SCTE 55-2 Downstream Packet the RPD has received since booting up, the RPD MUST set its internal ESF counter to the value of the Re-Sync Frame Number even if the Re-Sync Flag field is 0.
- The RPD MUST store a number of 55 byte ATM + FEC cells in its ATM receive buffer equal to the number specified in the Number of ATM Cells field, unless the ATM receive buffer is full. If the ATM receive buffer is full, the RPD MUST discard excess ATM cells which do not fit, without affecting any ATM cells already stored in the buffer, and MUST increment the Cell Discard Count by the number of cells discarded. The RPD MUST NOT store partial ATM cells in the ATM receive buffer.
- The RPD MUST store a number of slot allocations in its Slot Allocation Buffer equal to the number specified in the Number of Slot Allocations field, unless the Slot Allocation Buffer is full. If the Slot Allocation Buffer is full, the RPD MUST discard excess slot allocations which do not fit, without affecting any slot allocations already stored in the buffer, and MUST increment the Schedule Discard Count by the number of cells discarded. The RPD MUST NOT store partial slot allocations in the Slot Allocation Buffer.

6.1.3.2 Upstream

The upstream packet structure is depicted in Figure 3. Descriptions of each of the fields are contained in Table 7 through Table 11. The tunnel header is identical to the L2TPv3 tunnel header described in [R-UEPI].

The encapsulated payload is made up of the SCTE 55-2 OOB Upstream Header, and 0 to 9 ATM cells with attached timing, power, and RS Decode status information. These ATM cells are fed into the reassembly portion of the SAR in the 55-2 Controller in order to regenerate IP packets.

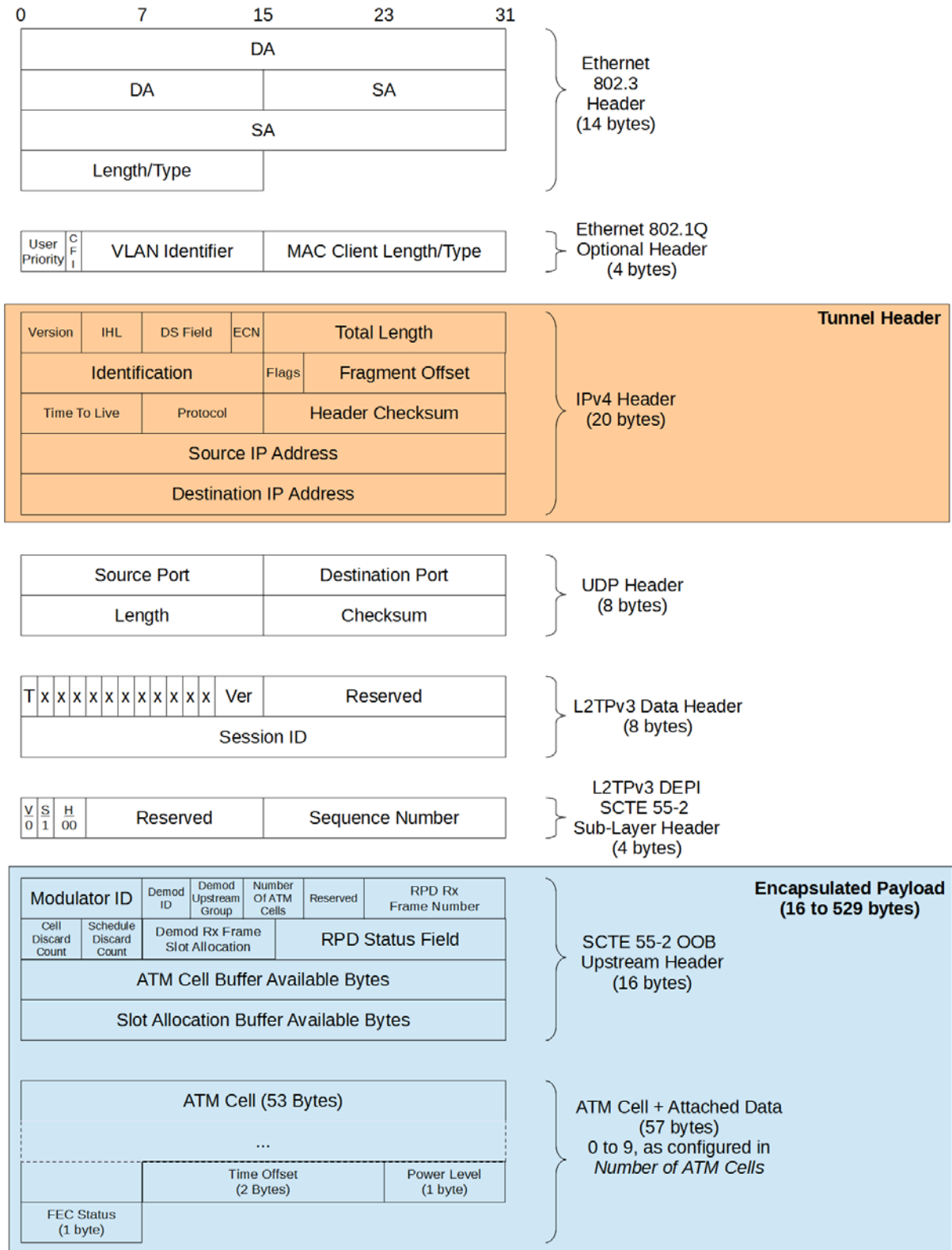

Figure 3 - SCTE 55-2 Upstream Packet Format

Table 7 - Upstream Tunnel Header Field Description

Field	Size (bits)	Description
Version	4	Always set to 4
IHL	4	The length of the outer IP header measured in 32-bit words
TOS	8	Copied from encapsulated payload header
Total Length	16	The Total Length measures the length of the entire encapsulated IP datagram, including the outer IP header, the inner IP header, and its payload.
Ident	16	Unique value for the tunnel header
Flags	3	R- unused DF – copied from encapsulated payload header MF- unused
Fragment Offset	13	Unused
TTL	8	Set to value appropriate to pass through the CIN.
Protocol	8	Set to 115
Header Checksum	16	IP Checksum of Tunnel Header
Source IP Addr	32	IP Address of the R-PHY Tunnel entry point
Dest IP Addr	32	IP Address of the CCAP Tunnel exit point

Table 8 - L2TPv3 Header Description

Field	Size (bits)	Description
T	1	Must be set to 0 to indicate data message.
x	1	Reserved, set to 0.
Ver	4	Must be set to 3 to indicate L2TPv3.
Reserved	16	Reserved, set to 0.
Session ID	32	Identifies the L2TPv3 Tunnel this packet belongs to.

Table 9 - L2TPv3 DEPI 55-2 Sublayer Header Description

Field	Size (bits)	Description
V	1	VCCV bit. Set to 0. Reserved for compatibility with [RFC 5085].
S	1	Sequence bit. Set to 1 to indicate that the sequence number field is valid. Set to 0 to indicate that the sequence field is not valid.
H	2	Extended Header Bits. Set to '00' to indicate a DEPI sublayer header that matches the current active pseudowire types.
Reserved	12	Reserved, set to 0.
Sequence Number	16	Sequence Number. The sequence number increments by one for each data packet sent, and may be used by the receiver to detect packet loss. The initial value of the sequence number SHOULD be random (unpredictable).

Table 10 - Upstream SCTE 55-2 OOB Header Field Description

Field	Size (bits)	Description
Modulator ID	8	Modulator Identifier. This value is assigned by the 55-2 Controller, and is inserted into the packet here so the controller can determine which modulator the packet was received from.
Demod ID	3	Demodulator Identifier. From 0 to 7. This value is assigned by the RPD to give a unique identifier to each demodulator that is coupled to a particular modulator.

Field	Size (bits)	Description
Demod Upstream Group	3	Upstream Group ID of this demod. From 0 to 7. This value is assigned by the 55-2 Controller. Upstream Group ID is equivalent to SCTE 55-2 Demodulator Number, but is zero indexed instead of 1 indexed. Upstream Group ID 0 corresponds to SCTE 55-2 Demodulator Number 1 (R1), Upstream Group ID 7 corresponds to SCTE 55-2 Demodulator Number 8 (R8).
Number of ATM Cells	4	Number of ATM cells contained in the message, from 0 to 9.
Reserved	4	Reserved, set to 0.
RPD Rx Frame Number	10	Frame number on which the encapsulated ATM cells were received.
Cell Discard Count	4	Number of cells that were discarded by the downstream ATM cell buffer since the last SCTE 55-2 Upstream Packet sent by the RPD.
Schedule Discard Count	4	Number of schedules that were discarded by the downstream ATM cell buffer since the last SCTE 55-2 Upstream Packet sent by the RPD.
Demod Rx Frame Slot Allocation	9	The slot allocation information corresponding to the Rx Frame number. See Table 6, ESF Framing Bits subfield for bit definitions.
RPD Status Field	15	Reserved for future use.
ATM Cell Buffer Available Bytes	32	Number of bytes available in the ATM cell buffer. This is used by the 55-2 controller to determine if it needs to slow down so as to avoid overflowing a buffer.
Slot Allocation Buffer Available Bytes	32	Number of bytes available in the Slot Allocation Buffer. This is used by the 55-2 controller to determine if it needs to send fewer schedules ahead of time so as to avoid overflowing the schedule buffer.

Table 11 - Upstream SCTE 55-2 OOB ATM Cell Field Description

Field	Size (bits)	Description
ATM Cell	424 (53 bytes)	Complete received ATM cell
Time Offset	16	Cell Receive time, as an offset from frame start that the ATM cell was received on, in units of 100ns. Values from 0 to 29999.
Power Level	8	Estimated signal strength of the received packet as determined by the demodulator. This field represents the power in dBmV using an 8-bit signed integer, in 0.25 dBmV increments.
FEC Status	8	Bits 7 to 3 – Unused, set to 0. Bit 2 – Uncorrectable indicator. Indicates the cell had too many errors for the FEC to correct. Bit 1 to 0 – Number of Corrected Errors. The number of errors corrected by the FEC on the received cell. From 0 to 3.

The RPD MUST generate one SCTE 55-2 Upstream Packet every frame for each demodulator on the RPD, even if no ATM cells were received on that frame.

When generating an SCTE 55-2 Upstream Packet:

- The RPD MUST include the frame number on which the receive ATM cells were received in the RPD Rx Frame Number field.
- The RPD MUST include the slot allocation for its associated upstream group corresponding to the frame number on which the ATM cells were received in the Demod Rx Frame Slot Allocation field. Upstream Group ID is equivalent to SCTE 55-2 Demodulator Number, but is zero indexed instead of 1 indexed. Upstream Group ID 0 corresponds to SCTE 55-2 Demodulator Number 1 (R1), Upstream Group ID 7 corresponds to SCTE 55-2 Demodulator Number 8 (R8).
- The RPD MUST set the Number of ATM Cells field to correspond to the number of ATM cells included in the payload.

- The RPD MUST set the Demod Upstream Group field to correspond to the Demod's configured upstream group.
- The RPD MUST set the ATM Cell Buffer Available Bytes field to correspond to the number of unused bytes in the ATM receive buffer at the time the SCTE 55-2 Upstream Packet is generated.
- The RPD MUST set the Slot Allocation Buffer Available Bytes field to correspond to the number of unused bytes in the Slot Allocation Buffer at the time the SCTE 55-2 Upstream Packet is generated.
- The RPD MUST attach the Time Offset, Power Level and FEC Status fields to each ATM cell in the payload, as shown in Figure 3 and Table 11.

The RPD MUST maintain a 4-bit Cell Discard Count, which counts how many cells are discarded from the receive ATM cell buffer. The value of the Cell Discard Count MUST be included in the Cell Discard Count field of the SCTE 55-2 Upstream Packet whenever it is sent, and the counter MUST be reset to 0 at that time.

The RPD MUST maintain a 4-bit Schedule Discard Count, which counts how many schedules are discarded from the Slot Allocation Buffer. The value of the Schedule Discard Count MUST be included in the Schedule Discard Count field of the SCTE 55-2 Upstream Packet whenever it is sent, and the counter MUST be reset to 0 at that time.

6.1.4 RPD System Implementation Overview (Informative)

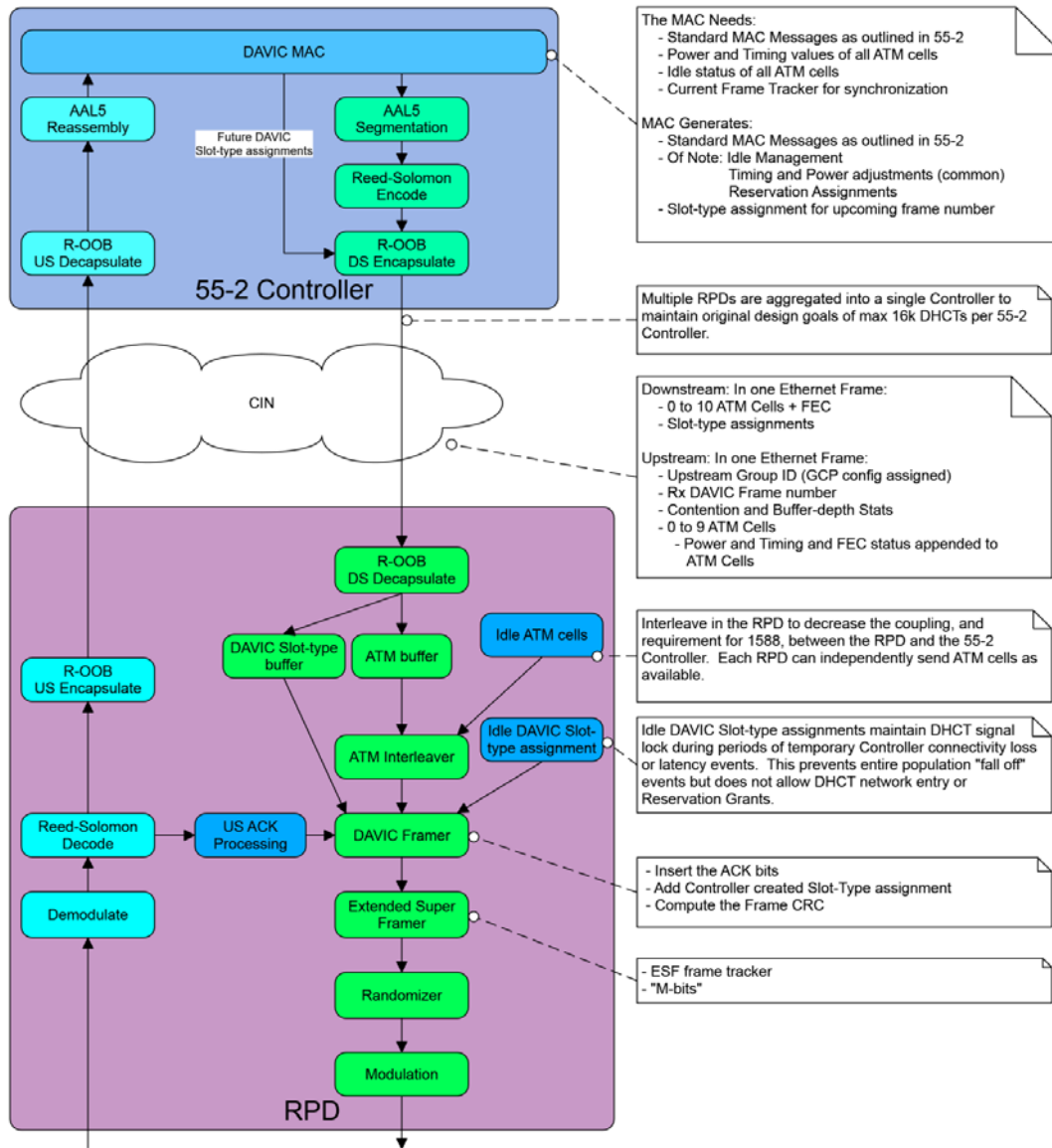

Figure 4 - SCTE 55-2 R-PHY Function Segmentation

Downstream:

- All downstream *Video Control Data* (unicast or multicast) and *DHCT Application Data* (unicast, multicast or broadcast) is sent to the 55-2 Controller,
- The 55-2 Controller performs ATM AAL5 segmentation and multiplexes this data together with 55-2 MAC messages,
- The 55-2 Controller performs the SCTE 55-2 FEC, and then packs up to one frame worth of ATM cells for the RPDs,
- The 55-2 Controller adds future slot assignments [SCTE55-2: SL-ESF Framing bits b0, b1-b6, and b16-b17],
- This data is encapsulated onto the Downstream R-OOB tunnel; upon reaching the RPD the ATM cells in the payload are placed in the receive ATM buffer and the slot assignments in the slot assignment buffer,

- On each frame-timeout the RPD reads 10 ATM cells from the receive ATM buffer into the interleaver. If the buffer doesn't contain 10 cells, IDLE ATM cells are generated to fill the frame up to 10,
- The output of the interleaver feeds into the SL-ESF framer where the slot assignment, or a default IDLE slot assignment, is combined with slot acknowledgment information collected from the upstream,
- The rest of the SCTE 55-2 framing and modulation is completed, and the data is sent to the DHCTs.

Upstream:

- In the upstream direction all DHCT-originated traffic is demodulated by the RPD to ATM Cells and encapsulated with individual power, timing, and FEC decode status information,
- This data, along with RPD status information, is sent back to the 55-2 Controller through a unicast Upstream tunnel,

The timing information and FEC decode status are used by the RPD to generate slot acknowledgements for the next Frame schedule.

All SCTE 55-2 MAC Functionality ([SCTE 55-2], section 2.3) is implemented in the 55-2 Controller.

The Principal CCAP Core sets the Downstream and Upstream frequencies of the RPDs, but certain network-wide constraints also need to be fulfilled. Proper 55-2 network functionality requires the 55-2 Controller to be configured with the same Downstream and Upstream frequencies as all the RPDs connected to that 55-2 Controller. The 55-2 Controller sends out broadcast MAC messages which are used during DHCT network entry ([SCTE 55-2] specification) which contain the Downstream and Upstream frequencies. If these settings are not unified across the 55-2 Controller and all RPDs connected to that 55-2 Controller, DHCTs will be unable to sign on.

6.1.5 RPD System Implementation Requirements (Normative)

- The RPD MUST implement sections 2.1 and 2.2 of the [SCTE 55-2] specification.
- The RPD MUST support Grade A (1.544Mbps) operation in the downstream.
- The RPD MUST support Grade B (1.544 Mbps) operation in the upstream.
- The RPD MUST support at least one SCTE 55-2 downstream channel.
- The RPD MUST support at least one SCTE 55-2 upstream channel.
- The RPD MAY support up to 8 SCTE 55-2 upstream channels.

6.1.5.1 IDLE ATM Cells and Slot Allocation Assignments (Normative)

The RPD MUST generate a DAVIC frame on the required schedule even if it must fill the frame with ATM IDLE cells. Missing DAVIC frames will cause all the DHCTs to drop off the network and be forced to do network re-entry; having the RPD send 'empty' frames is therefore preferable to no frames at all.

The RPD MUST support generation of up to a full DAVIC frame of IDLE ATM Cells with a default slot allocation if data is not received by the 55-2 Controller in time for frame transmission. The default slot allocation is configured through GCP.

6.1.5.2 Interaction between the RPD and 55-2 Controller (Normative)

The RPD MUST receive downstream from and MUST forward upstream messages to the 55-2 Controller via the downstream and upstream L2TPv3 tunnels.

The same GCP configuration mechanisms that configure the RPD also provide settings to the 55-2 module. The 55-2 module in the RPD requires the following GCP accessible configuration items:

Table 12 - RPD Read-Only Settings

Readable Value	Description	Bits
<Number of 55-2 Modulators>	Total Number of SCTE 55-2 Modulators present on the RPD	3

Readable Value	Description	Bits
<Number of 55-2 Demodulators per Modulator>	Number of SCTE 55-2 Demodulators per Modulator.	3

Table 13 - RPD Configurable Settings

Configurable Value	Description	Bits	Default	Configured By
<55-2 Controller IP>	IP Address of the 55-2 Controller the RPD should bind to. This can be configured in two ways: RPD boots and gets Principal CCAP Core & 55-2 Controller IP via DHCP. RPD boots and gets just Principal CCAP Core IP from DHCP. The RPD then gets 55-2 Controller IP as an Auxiliary Core list from the Principal CCAP Core via GCP TLV.	32	<none>	Principal CCAP Core or DHCP
<Upstream Frequency>	Frequency of the Upstream channel, in Hz.	32	<none>	Principal CCAP Core
<Downstream Frequency>	Frequency of the Downstream channel, in Hz.	32	<none>	Principal CCAP Core
<Downstream Power>	Power level of downstream modulator, in dBmV.	32	<none>	Principal CCAP Core
<Service Channel Last Slot>	Maximum value of the ESF counter before it rolls over. The RPD will increment its own ESF counter, but MUST reset its frame counter register to a value specified by the 55-2 Controller if the Re-Sync flag is set in the 55-2 downstream packet.	10	0x3E8	55-2 Controller
<Default Ranging Interval>	This is how frequently to use the <Default Ranging Slot Configuration> values when using the default slot allocation for DAVIC frame generation (1 = every frame, 2 = every 2 frames, etc. 0 = never).	8	0x08	55-2 Controller
<Default Ranging Slot Configuration>	This is the slot configuration to output whenever the default slot allocation generator outputs an allocation with a ranging slot.	9	0x00	55-2 Controller
<Default Non-Ranging Slot Configuration>	This is the slot configuration to output whenever the default slot allocation generator outputs an allocation without a ranging slot.	9	0x1B	55-2 Controller
<Randomizer>	One of two randomizer polynomials. A value of 0 corresponds to X^6+X+1 . A value of 1 corresponds to X^6+X^5+1 . See Section 6.1.6.6 for additional information on the Randomizer.	1	0x0	55-2 Controller

Table 14 - Per Modulator Configurable Settings

Configurable Value	Description	Bits	Default	Configured By
<Modulator ID>	Number set by the SCTE 55-2 Controller which is included in all SCTE 55-2 Upstream Packets so as to identify which Modulator the packets came from.	8	0x00	55-2 Controller

Table 15 - Per Demodulator Configurable Settings

Configurable Value	Description	Bits	Default	Configured By
<Max DHCT Distance>	The distance from the RPD to the furthest DHCT. Range: 0km – 248km; Step: 31km. This is converted into a timing offset in the RPD to apply to incoming cell receive times.	8	0x00	55-2 Controller
<Upstream Group ID>	The Upstream Group ID to assign the demodulator. The 55-2 Controller should distribute the Groups evenly through the RPD population. Range: 0 – 7. These are equivalent to 55-2 demodulator numbers, but zero indexed instead of 1 indexed (0 corresponds to demod number 1, 7 corresponds to demod number 8). Each demodulator on an RPD has a unique upstream group ID. If multiple demodulators are present, they should each have a different default upstream group ID.	3	0x0 (to 0x7*)	55-2 Controller

The RPD MUST accept all of the GCP configuration options in Table 13 to Table 15.

The RPD MUST present one instance of the GCP configuration options in Table 14 for each SCTE 55-2 modulator present in the RPD.

The RPD MUST present one instance of the GCP configuration options in Table 15 for each SCTE 55-2 demodulator present in the RPD.

The RPD MUST use the default values in Table 13 to Table 15 unless otherwise configured by the SCTE 55-2 controller.

The RPD MUST assign unique <Upstream Group IDs> to each demodulator when the design has a single modulator with multiple demodulators. If the design has a modulator plus a single demodulator independently replicated more than once then all demodulators MAY use the default value of 0x0.

The RPD MUST support Session ID establishment as described in section 7.6.2.1 of [R-DEPI]. Each 55-2 Controller assigns multicast Session IDs for data pseudowires for all its connected RPDs. Unicast upstream sessions are negotiated in the normal way, with the 55-2 Controller assigning Session IDs to data pseudowires for all connected RPDs.

6.1.5.3 Timing Considerations

55-2 Link layer functions are split between the RPD and the 55-2 Controller. The 55-2 Controller performs ATM SAR functions and forward path FEC encoding; all other Link layer functions are in the RPD. PHY layer functionality is in the RPD. MAC level functionality is performed in the 55-2 controller.

The strictest timing consideration in 55-2 is the slot acknowledgement. This is entirely contained within the RPD, minimizing timing constraints on the CIN. Support for the full set of SCTE 55-2 features including reservation mode requires synchronization between the RPD and the 55-2 Controller. The approach used is still relatively tolerant of network jitter and latency changes, by including small data buffers in the RPD to handle those occurrences.

The 55-2 Controller supports operation as a PTP (1588) Ordinary Clock consistent with the Core_Slave Architecture as described in [R-DTI].

The RPD MUST support the [R-DTI] Node_Slave Architecture for PTP (1588) synchronization.

NOTE: Node_Master architectures as described in [R-DTI] will not function for 55-2 due to the multicast nature of the 55-2 downstream.

In the case of CIN deployments where implementing IEEE 1588 is impractical, contention-based operation is possible but reservation mode is not supported. In this mode, the RPD and 55-2 Controller are decoupled from a timing perspective.

The RPD 55-2 module **MUST** be capable of operating without IEEE 1588 synchronization. The RPD 55-2 module doesn't need to be aware of its synchronization status with respect to the 55-2 Controller, the 55-2 controller will automatically handle desynchronized states by disabling reservation mode access.

The RPD **MUST** buffer upstream ATM cells for one whole ESF duration (3ms) after the end of the ESF in which they are received. This ensures that all the cells received in a particular ESF are ready to be transmitted at the same time, even in cases where the maximum DHCT distance setting is set to a high value.

6.1.5.4 Base Downstream/Upstream Time Offset

The RPD **MUST** maintain separate downstream and upstream frame timers.

The RPD downstream and upstream frame timers **MUST** be synchronized but offset from each other, with the upstream timer lagging behind the downstream timer.

This offset is necessary to ensure that received ATM cells have the correct receive timing attached to them to account for a certain base level of delay involved in modulation on both the downstream in the RPD and upstream in the set top box. The downstream timer is used to determine when to generate a new ESF for transmission, and the upstream timer is the time reference to determine when a cell was received. The exact base offset required will vary based on implementation of the RPD and how much delay is introduced in the implementation.

6.1.5.5 Maximum DHCT Distance

The RPD **MUST** support the maximum DHCT distance specified via GCP, from 0 to 248km, in 31 km increments.

A DHCT should be able to range and sign-on correctly as long as the maximum DHCT distance is within 1 increment of its actual distance (so a set top box 10km from the RPD should work correctly with the distance set to either 0 or 31 km). The lower of the two distance offsets is preferred, and the majority of RPD deployments are expected to use 0 km offset.

The RPD **MUST** convert the distance into an additional maximum DHCT distance time offset as shown in Table 16.

The RPD **MUST** add the maximum DHCT distance time offset to the implementation specific time offset described in Section 6.1.5.4. The distances correspond to the following time offsets:

Table 16 - Distance to Time Offset Conversion

Distance (km)	Time Offset (us)
0	0
31	300
62	600
93	900
124	1200
155	1500
186	1800
217	2100
248	2400

6.1.6 RPD 55-2 Signal Processing Requirements

6.1.6.1 ATM IDLE Cells

The RPD **MUST** generate ATM IDLE cells as defined in Figure 5 for compatibility with legacy 55-2 systems.

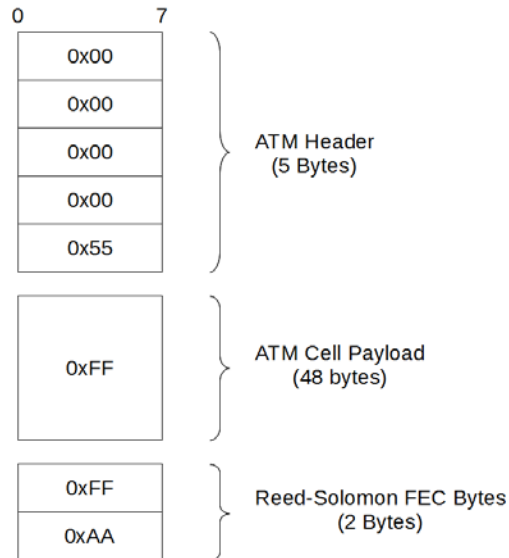

Figure 5 - ATM IDLE Cell Format

6.1.6.2 ATM Interleaver

The RPD MUST support the ATM interleaver defined in [SCTE 55-2], Figure 2-7.

The RPD MUST fill the ATM interleaver with ATM IDLE cells if 10 ATM cells of useful payload are not available in the ATM cell buffer.

6.1.6.3 Slot Allocation Processor.

The slot allocation processor consists of a buffer containing slot allocations provided from the 55-2 Controller, and a default slot allocation generator to create the slot allocation if none are present in the buffer, or the buffer is not aligned with the RPD’s current frame number.

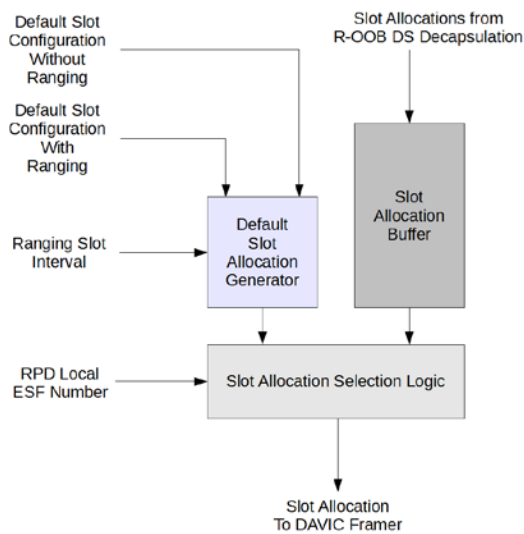

Figure 6 - Slot Allocation Processor

The RPD MUST support GCP configuration of Default Slot Configuration with and without ranging and the ranging slot interval by the 55-2 Controller.

The RPD MUST use the most recently configured Default Slot Allocation values the next time a Default Slot Allocation would be generated.

The RPD's Default Slot Allocation Generator MUST perform the following functions:

- Track the number of ESFs where it has output the default slot allocation.
- Every N ESFs, where N is the configured Ranging Slot Interval, output the Default Slot Configuration with Ranging.
- Output the Default Slot Configuration without Ranging on all other ESFs.
- Apply the selected 9-bit Default Slot Configuration to all 8 upstream channel slot allocations.

The RPD MUST accept input into its slot allocation buffer from SCTE 55-2 Downstream packets. Each slot allocation buffer entry MUST contain the values of the b0, b1-b6, and b16-b17 bits for R1 to R8 [SCTE 55-2, section 2.1.9] and a target ESF number.

As already stated in Section 6.1.2.1, the RPD MUST delete the outstanding Slot Allocation assignments in the Slot Allocation Buffer when the Re-Sync Flag is asserted in the downstream messages. The 55-2 Controller will deliver slot allocation assignments in an increasing target ESF number, respecting correct roll-over. The 55-2 Controller may not deliver the slot allocation buffers in serially increasing target ESF numbers (there may be gaps). If the 55-2 Controller asserts the ESF Re-sync Flag the slot allocation assignments may not be increasing with respect to previously delivered assignments but will be increasing with respect to the new ESF number.

The RPD MUST determine whether to use the slot allocation stored in the buffer or the slot allocation generated by the default slot allocation generator by comparing the RPD local ESF number with the ESF number in the buffer. Depending on the result of the comparison, the RPD performs one of three actions:

1. *RPD Local ESF Number > Buffer target ESF number.* The buffer slot allocation is stale; the RPD MUST discard this allocation and look at the next word (if available). The RPD MUST continue doing this until either state 2 or 3 is true so that a slot allocation is ready to output on the next ESF.
2. *RPD Local ESF Number = Buffer target ESF number.* The RPD MUST output the buffer slot allocation on the next ESF.
3. *RPD Local ESF Number < Buffer target ESF number, or Buffer Empty.* The RPD MUST output the Default Slot Allocation on the next ESF. This condition effectively waits for the RPD ESF number to match the buffer ESF number, at which point it becomes condition 2.

The RPD MUST handle wraparound of the ESF counter in such a way that it can correctly determine if a target ESF number is in the future (condition 3) or in the past (condition 1). That is to say that the number 2 is actually greater than 1022 (in the future) near the counter wraparound point (0).

The RPD can handle wraparound of the ESF counter by subtracting the current ESF Number from the slot allocation buffer's output ESF Number. Standard subtraction and interpreting the result as a two's complement number is all that is required to determine if a target ESF number is in the future or the past:

- When the difference is positive, we have condition 1.
- When the difference is zero, we have condition 2.
- When the difference is negative, we have condition 3.

By way of example consider the following:

Current ESF - Buffer ESF = Result	Current ESF - Buffer ESF = Result
0x3FE - 0x3FC = 0x002	0x002 - 0x3FE = 0x004
0x3FE - 0x3FD = 0x001	0x002 - 0x3FF = 0x003
0x3FE - 0x3FE = 0x000	0x002 - 0x000 = 0x002
0x3FE - 0x3FF = 0x3FF (-1)	0x002 - 0x001 = 0x001
0x3FE - 0x000 = 0x3FE (-2)	0x002 - 0x002 = 0x000

Current ESF - Buffer ESF = Result	Current ESF - Buffer ESF = Result
0x3FE - 0x001 = 0x3FD (-3)	0x002 - 0x003 = 0x3FF (-1)

6.1.6.4 SL-ESF (DAVIC) Framer

The RPD MUST support SL-ESF (DAVIC) Framing as specified in [SCTE 55-2], section 2.1.9.

For each SL-ESF (DAVIC) frame, the RPD MUST:

- Obtain 10 interleaved ATM cells from the Interleaver.
- Obtain bits b0, b1-b6 and b16-b17 for each of R1 to R8 from the Slot Allocation Processor.
- Obtain bits b7-b15 for Rx from the upstream acknowledgement processing logic (where x-1 corresponds to the GCP configured upstream groups of all of the demodulators on the RPD which are associated with a particular downstream channel).
- Set upstream acknowledgement bits for other upstream channels (all channels excluding Rx, described in the previous point) to 0.
- Compute the CRC 6 parity bits (b17-b23 for R1 to R8)

6.1.6.5 Extended Super-Framer

The RPD MUST support Extended Super-Framer as described in [SCTE 55-2] section 2.1.5.

6.1.6.6 Randomization

The RPD MUST perform randomization as described in [SCTE55-2, Table 2-2].

The RPD MUST support selection between two randomizer polynomials via GCP: X^6+X+1 and X^6+X^5+1 for legacy 55-2 system compatibility.

The randomizer polynomial is set at initial RPD configuration and is not expected to change during operation.

6.1.6.7 Downstream Modulation

The RPD MUST support downstream modulation as described in [SCTE 55-2] sections 2.1.1 and 2.1.2.

6.1.6.8 Upstream Demodulation

The RPD MUST support upstream demodulation as described in [SCTE 55-2] section 2.2.1.

The RPD upstream demodulator MUST provide power and timing information for each demodulated cell, formatted as described in Table 11 - Upstream SCTE 55-2 OOB ATM Cell Field Description.

6.1.6.9 RS Decode

The RPD MUST support Reed-Solomon decoding as described in [SCTE 55-2], section 2.2.3.1.

The RPD MUST provide the following 3-bit Reed-Solomon Decode Status Field for each ATM cell it decodes:

Table 17 - RS Decode Status Field

Bits	Description
2	Uncorrectable indicator. Indicates the cell had too many errors for the FEC to correct.
1 to 0	Number of Corrected Errors. The number of errors corrected by the FEC on the received cell. From 0 to 3.

6.1.6.10 Upstream Acknowledgement Processing

Upstream acknowledgement processing requires parsing the cell receive time to determine the slot in which an ATM cell was received such that the correct acknowledgement bits can be set.

The RPD **MUST** support upstream acknowledgement processing as defined in [SCTE 55-2], section 2.2.6.1.

The RPD **MUST** support upstream slot start and end times according to Table 18. The times in Table 18 are relative to the start of the frame.

Table 18 - Upstream Slot Start and End Times

Slot Number	Start Time (in units of 100ns)	End Time (in units of 100ns)
0	0	3316
1	3317	6632
2	6633	9999
3	10000	13316
4	13316	16632
5	16633	19999
6	20000	23316
7	23317	26632
8	26633	29999

NOTE: Slots 2, 5, and 8 are slightly longer than the others as slot groups are resynchronized every 1ms.

The RPD **MUST** acknowledge the burst in the slot in which its burst started being received.

The RPD **MUST** take frame number rollover into account when performing slot acknowledgement, since cells received in the later slots will often be processed when the downstream frame number has already advanced.

The RPD **MUST** only acknowledge cells that are correctly decoded by the FEC, including correctable FEC errors.

The RPD **MUST NOT** acknowledge cells that fail FEC decoding.

The RPD slot acknowledgement process **MUST** function correctly regardless of the time offset between the downstream and upstream frame timers.

The RPD **MUST** acknowledge receipt of ATM cells in the correct slot and frame corresponding to the upstream frame timer time when the cell was received.

The RPD **MUST** send slot acknowledgements to the SL-ESF (DAVIC) Framer two frames after the frame number the acknowledgements belong to as described in [SCTE 55-2], figure 2-11, for 1.544Mbps upstream/downstream acknowledgement relationship.

6.2 [SCTE 55-1] Remote PHY Solution³

To facilitate the delivery of OOB streams from the headend to the customer-facing CPE via the Remote PHY architecture, a solution is needed that delivers the OOB streams to the RPD via the same Ethernet carriers that the rest of the services traverse. The following sections describe an approach to implementing SCTE 55-1 in a Remote PHY environment.

NOTE: All of the requirements in this section only apply to devices that implement SCTE 55-1 supports. Although this section discusses CCAP Core throughout, the core functionality may alternatively be implemented by a Video Core or OOB Core.

³ Revised per R-00B-N-15.1399-3 on 1/8/15 by JB.

6.2.1 Forward Path⁴

This approach is similar to the process used today to deliver OOB control data. The OM is responsible for receiving the OOB source data streams and creating a multiplexed signal in accordance with [SCTE 55-1]. However, the OM does not RF modulate the processed MPEG transport stream; instead the MPEG transport stream containing the OOB is IP multicast via UDP to the CCAP Core over an Ethernet link.

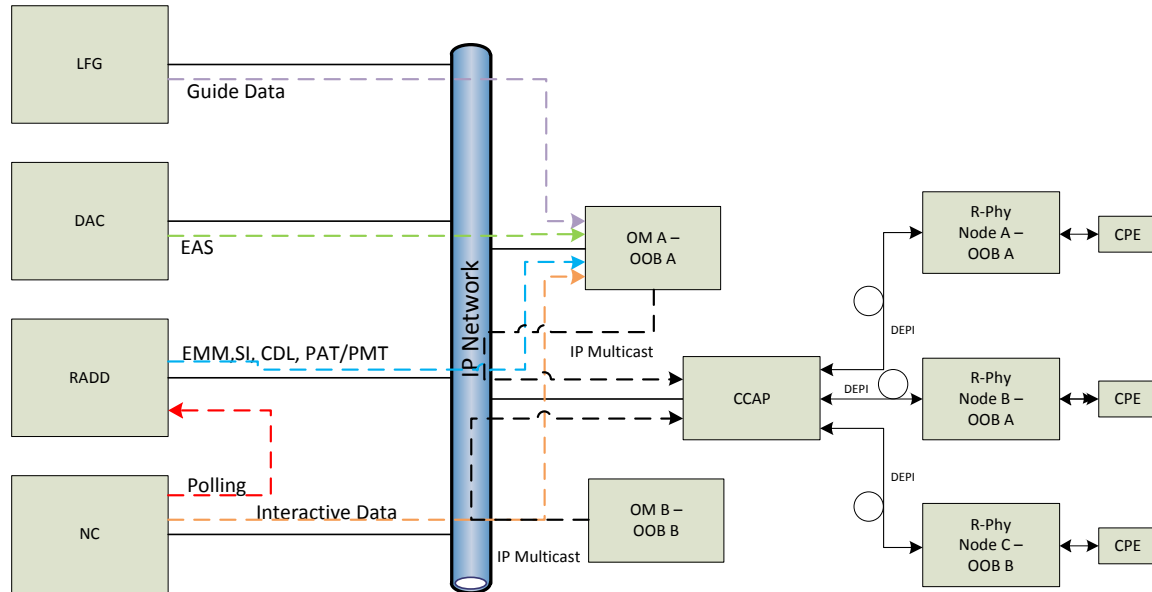

Figure 7 - OM as a Multiplexer

The CCAP Core joins each IP multicast stream that is destined to the RPDs it serves and transparently forwards the received multicast payload contents. The CCAP Core encapsulates the OOB payload received via [DEPI] and forwards the DEPI-encapsulated payload to the appropriate RPD. There may be more than one OM providing OOB streams that the CCAP Core joins and forwards to the configured RPD.

The RPD receives the DEPI-encapsulated packets and QPSK modulates per SCTE-55-1. The modulated signal is output in the downstream RF spectrum, as instructed by the CCAP Core via DEPI.

6.2.1.1 Out-of-Band Stream Type and Scope

The CCAP Core is expected to deliver OOB MPEG transport streams to each RPD it serves. While some of the OOB data will be the same for all RPDs, some data types will be unique per RPD. Therefore, the CCAP Core will likely need to deliver more than one OOB MPEG transport stream and ensure that each is delivered to the appropriate RPD. Each OM can only output a single OOB multiplex; therefore, a CCAP Core may receive OOB streams from multiple OMs. Each of these streams is destined for a different set of RPDs. See the example in the scenario depicted in Figure 8.

⁴ Revised per R-00B-N-15.1399-3 on 1/8/15 by JB.

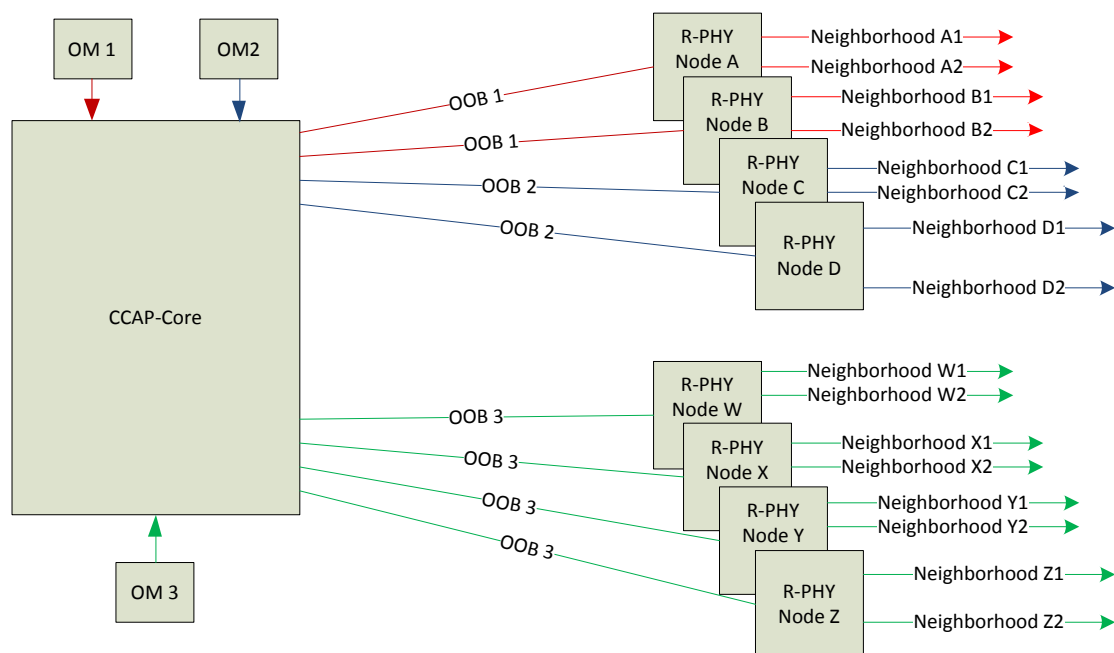

Figure 8 - Unique OOB Delivery to Multiple Sets of RPDs

In this case, the CCAP Core delivers three different OOB MPEG transport streams, one from each unique OM.

6.2.1.2 R-OOB Data Path Downstream⁵

The downstream OOB data path relies on tunneling to isolate the OOB traffic from the DOCSIS and MPEG Video traffic. The tunneling greatly simplifies the networking requirements placed on the RPD.

The capacity of each of the downstream/upstream tunnels (one upstream/downstream tunnel per RPD) needs to align with the throughput of the SCTE 55-1 link, i.e., 2,048 Mbps. Each RPD MUST have enough buffering capacity to support the bursty nature of downstream delivery (the implementation is vendor specific).

The RPD MUST have enough buffering to support up to 10 mS of network jitter.

OM2000 will NOT include NULL frames in its Ethernet output stream; generally the OM only outputs non-null packets in its Ethernet output transport streams. The expectation is thus that the downstream QPSK modulator inserts nulls as necessary. The Remote PHY Device MUST insert NULL packets as necessary to maintain the required module rate of the SCTE 55-1 downstream QPSK channel. The downstream modulator does not need to maintain precise inter-packet timing. The modulator can effectively insert NULLs wherever necessary without concern about excessive data packet displacement.

NOTE: There are no PCR time stamps in any of the SCTE-55-1 streams; all MPEG streams coming out of the OM are asynchronous. So there is no need to maintain time-sync between the OM and the Remote PHY Device.

6.2.1.3 Forward Path Packet Format⁶

The forward path DEPI packet format is identical to the DEPI MPT format.

6.2.1.4 SCTE 55-1 Forward Path Requirements⁷

The CCAP Core MUST support sending at least one SCTE 55-1 DEPI tunnel to the Remote PHY Device(s).

⁵ Added per R-00B-N-15.1399-3 on 1/8/15 by JB.

⁶ Added per R-00B-N-15.1399-3 on 1/8/15 by JB.

⁷ Added per R-00B-N-15.1399-3 on 1/8/15 by JB.

The CCAP Core MAY support sending additional SCTE 55-1 DEPI tunnels.

The RPD MUST support receiving at least one SCTE 55-1 DEPI tunnel.

The RPD MAY support receiving additional SCTE 55-1 DEPI tunnels.

The CCAP Core MUST support forwarding SCTE 55-1 DEPI tunnels as multicast packets.

The RPD MUST support receiving SCTE 55-1 DEPI tunnels as multicast packets.

6.2.2 Return Path⁸

In the return path, the R-PHY Device provides a function similar to the legacy SCTE 55-1 Advanced Return Path Demodulator (ARPD). This includes demodulation of the upstream RF OOB signal as described in the SCTE 55-1 specification. The demodulated data is transmitted upstream as augmented ATM cells encapsulated in a UEPI OOB pseudowire. The exact format of the augmented ATM cells is detailed in a separate specification, the “Advanced Return Path Demodulator (ARPD) Interface Protocol” [ARPD]. .

The OOB pseudowire is terminated by the CCAP Core. The CCAP Core removes the augmented ATM cells from the UEPI encapsulation, and encapsulates the cells in IP/UDP for delivery to the Network Controller. In this way the ARPD functionality is split between the Remote PHY Device and the CCAP Core, with the Remote PHY Device implementing the demodulation, and the CCAP Core implementing the network side interface of the ARPD including IP/UDP encapsulation.

Since the ARPD functionality is split between the Remote PHY Device and the CCAP Core, the combined functionality is referred to here as a “virtual” ARPD. In a similar way, the functionality of the OM is split between the OM2000 which provides multiplexing of MPEG streams, the CCAP Core which provides DEPI encapsulation, and the Remote PHY Device which provides modulation. This is referred to as a “virtual” OM. These concepts are illustrated in Figure 1.

NOTE: In some legacy systems, the ARPD may send RADD-bound directly to the RADD; however, this setup is not recommended for Remote PHY systems.

In order to simplify the implementation in the CCAP Core, the virtual ARPD MUST send all traffic to the NC. The NC is responsible for identifying RADD-bound traffic and forwarding it to the RADD.

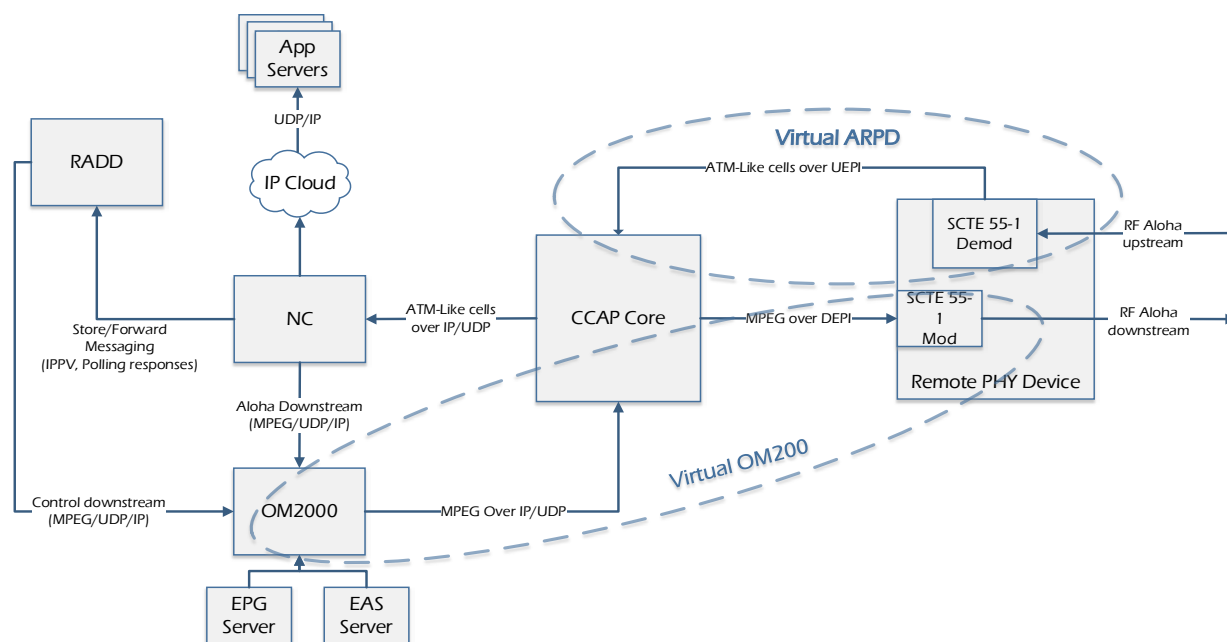

Figure 9 - SCTE 55-1 Remote PHY Implementation

⁸⁸ Added per R-00B-N-15.1399-3 on 1/8/15 by JB.

6.2.2.1 ARPD-to-NC Interface⁹

The interface from the Remote PHY Device to the CCAP Core contains augmented ATM cells. This interface is documented fully in the “Advanced Return Path Demodulator (ARPD) Interface Protocol” [ARPD]. This specification is being licensed free of charge to vendors for the purpose of implementing DAA devices.

6.2.2.2 Scaling

Figure 10 depicts a legacy SCTE 55-1 system.¹⁰

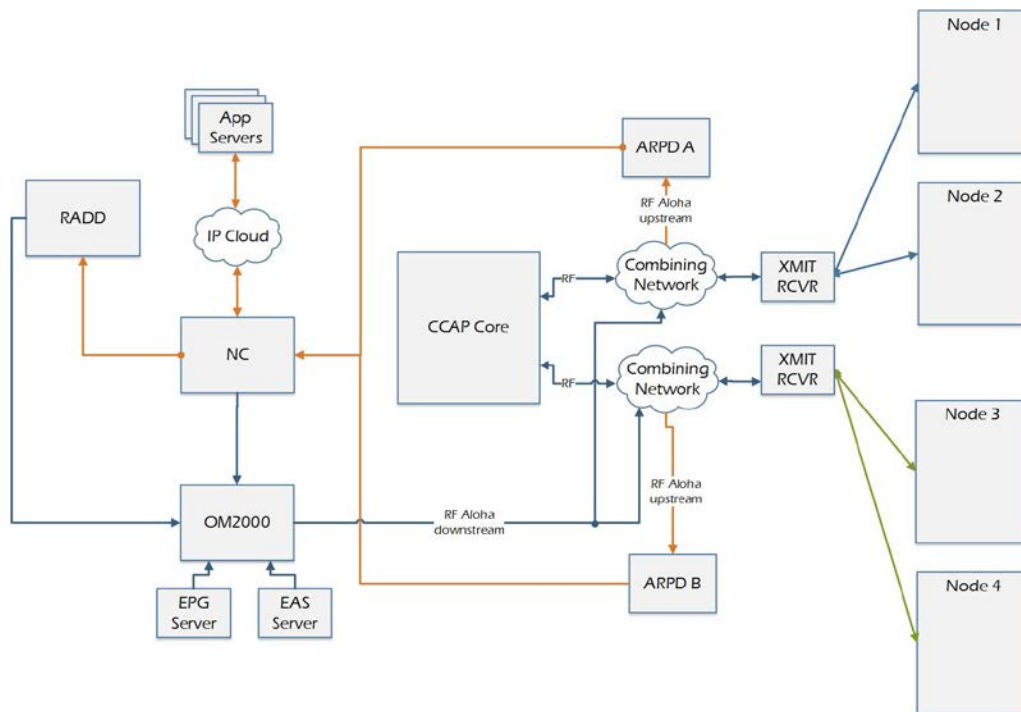

Figure 10 - Legacy System

In this system several limitations exist with respect to scaling, including the number of ARPDs per NC, the number of RF ports per ARPD, and the number of demodulators per ARPD RF port. This leads to a limit on the total number of demodulators per NC. These limitations are mitigated by the RF combining network, as several fiber nodes may be combined and fed to a single ARPD demodulator. For example, nodes 1 and 2 in figure 2 are combined and fed to a single demodulator.

In a Remote PHY system, each fiber node contains an RPD which demodulates the upstream signal, thus removing the scaling benefits of the legacy system combining network. In order to mitigate the scaling limitations, the Remote PHY System may aggregate the return path traffic from several RPDs and feed that upstream to the NC presented as being received from a single ARPD demodulator.

The CCAP Core may aggregate upstream OOB traffic from multiple Remote PHY Devices and present them on the network side as being sourced from a single SCTE 55-1 ARPD module by using the same source IP address and destination UDP port, as well as the same ARPD source, port, and demod identifiers for all of the appropriate Remote PHY Device upstream OOB traffic. This allows the operator to maintain the same fiber node to OOB service group distribution as was present prior to the RPHY implementation.

⁹ Added per R-00B-N-15.1399-3 on 1/8/15 by JB.

¹⁰ Added per R-00B-N-15.1399-3 on 1/8/15 by JB.

NOTE: Each Virtual ARPD MUST use a unique source IP address and a unique destination UDP port in packets sent to the NC. The NC relies on IP address and UDP port to identify the ARPD from which the traffic is arriving. The destination UDP port to use MUST be configurable on the CCAP Core.

Figure 11 presents the same system as above after being upgraded to Remote PHY. In the Remote PHY system fiber node 1 and 2 still appear to the NC to be serviced by a single ARPD, while fiber node 3 and 4 are appear as a separate ARPD.

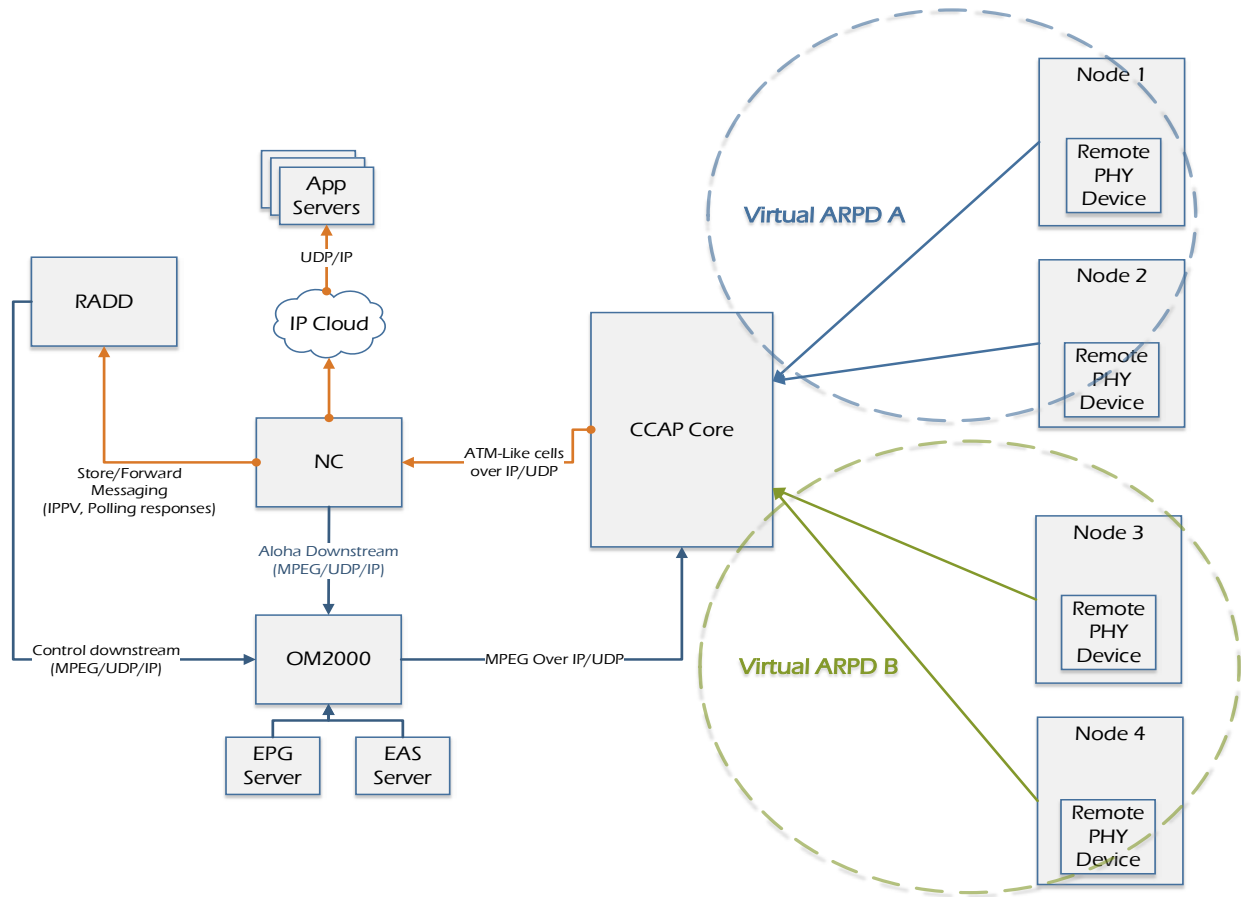

Figure 11 - Remote PHY System with Virtual ARPDs

Figure 12 demonstrates several methods for distributing the Remote PHY Device within a virtual ARPD.

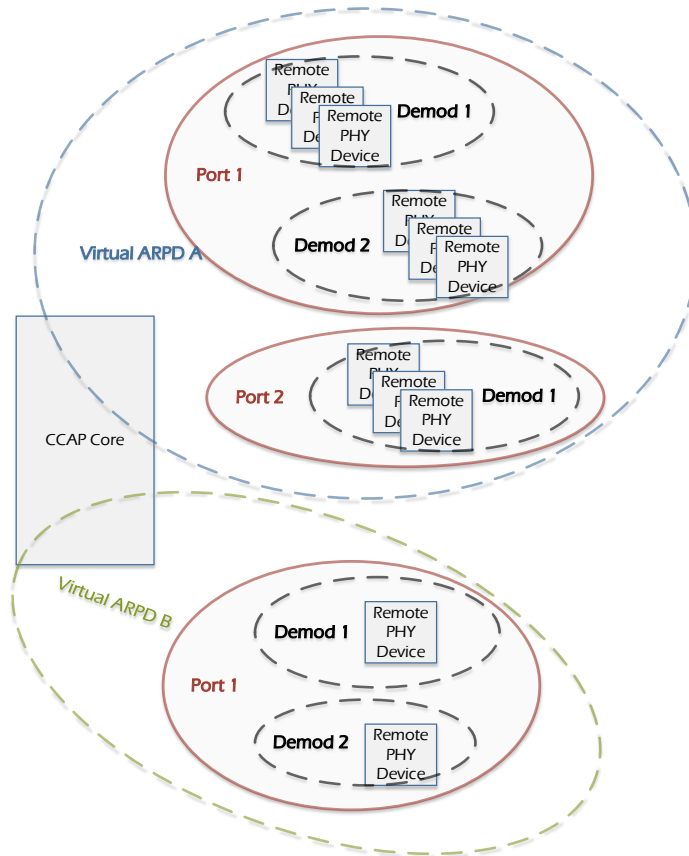

Figure 12 - Example Virtual ARPD/Remote PHY Device distribution

In the system depicted in Figure 12, the CCAP Core implements two virtual ARPDs. Virtual ARPD A aggregates multiple Remote PHY Devices on each ARPD demod, while virtual ARPD B has a single Remote PHY Device per demod. Both methods are acceptable, and choosing which one to use depends on the specific scaling needs of the system.

NOTE: The maximum number of Remote PHY Devices per demod will be dependent on the capabilities of the specific Network Controller being used.

The CCAP Core is responsible for configuring, via GCP, the attached RPDs with the appropriate ARPD Source ID, RF Port ID, and demod ID corresponding to each UEPI tunnel. The RPD uses this information when forming the ARPD Datagram.

6.2.2.3 Return Path Packet Formats¹¹

The packets from the Remote PHY Device to the CCAP Core includes an ARPD Datagram as described in “Advanced Return Path Demodulator (ARPD) Interface Protocol” encapsulated in a UEPI OOB pseudowire. The source IP address is that of the Remote PHY Device. The destination IP address is that of the CCAP Core. The packet includes a 4 byte L2TPv3 sublayer header which contains flag bits and a sequence number.

¹¹ Added per R-00B-N-15.1399-3 on 1/8/15 by JB.

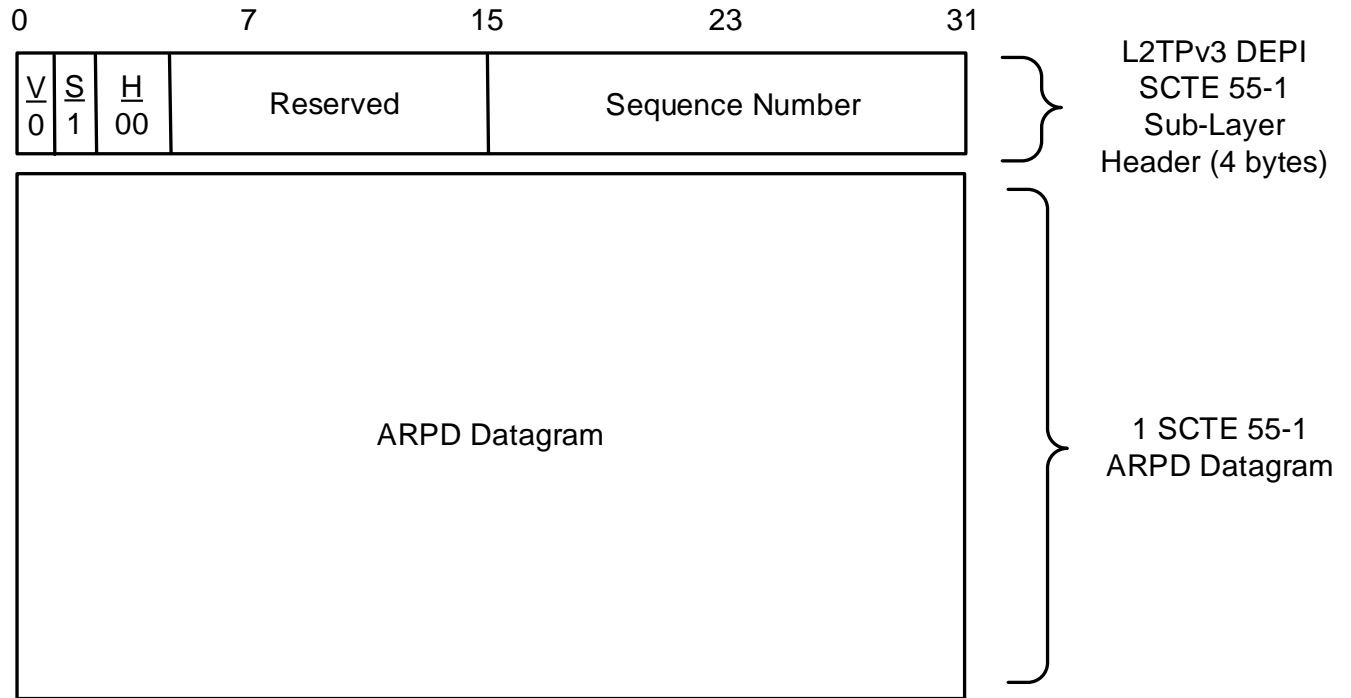

Figure 13 - UEPI SCTE 55-1 Packet Format

Table 19 - Header Format for SCTE 55-1 sublayer Header and Payload

Field	Description
V	1 bit. VCCV bit. Set to 0. Reserved for compatibility with [RFC 5085].
S	1 bit. Sequence bit. Set to 1 to indicate that the sequence number field is valid. Set to 0 to indicate that the sequence field is not valid.
H	2 bits. Extended Header bits. Set to '00' to indicate a DEPI sublayer header that matches the current active pseudowire type (either D-MPT or PSP).
Reserved	12 bits. Reserved field. Set to all zeroes at the transmitter, ignored at the receiver.
Seq Num	2 bytes. Sequence Number. The sequence number increments by one for each data packet sent, and may be used by the receiver to detect packet loss. The initial value of the sequence number SHOULD be random (unpredictable).

The packets from the CCAP Core to the NC1500 are formatted as described in “Advanced Return Path Demodulator (ARPD) Interface Protocol”. The format of the outer layers are shown in the Figure 14 below. The source IP address is that of the “virtual” ARPD. The destination IP address is that of the NC1500.

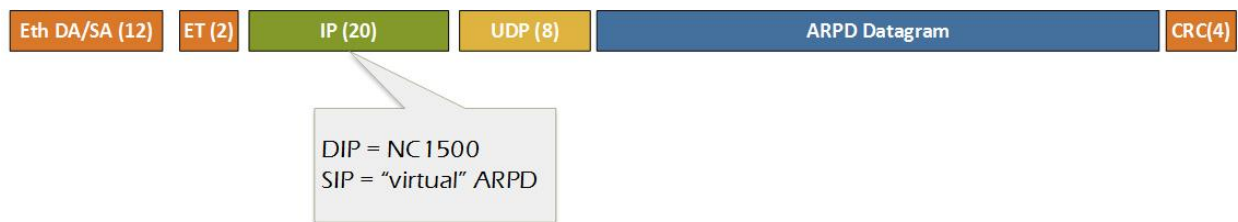

Figure 14 - CCAP Core to Network Controller Packet Format

6.2.2.4 SCTE 55-1 Return Path Requirements (Normative)¹²

The RPD MUST support sending at least one SCTE 55-1 UEPI tunnel to the CCAP Core

The RPD MAY support sending additional SCTE 55-1 UEPI tunnels (up to one tunnel per SCTE 55-1 demodulator on the RPD)

The RPD MUST support sending packets from multiple demodulators on a single UEPI tunnel

The RPD MUST support the ARPD interface protocol as described in the “Advanced Return Path Demodulator (ARPD) Interface Protocol” [ARPD], including encapsulating upstream SCTE 55-1 data into ARPD Datagrams

The RPD MUST support at least one virtual ARPD Source ID, RF Port ID, and demod ID

The RPD MAY support more than one virtual ARPD Source ID, RF Port ID, and demod ID

The RPD MUST support aggregating multiple physical demodulators onto a single virtual ARPD demod ID

The CCAP Core MUST support forwarding of SCTE 55-1 upstream packets encapsulated in IP/UDP

6.2.3 System Timing Considerations¹³

SCTE 55-1 operation in a Remote PHY system requires no clock synchronization between the various components, such as the OM2000, NC, CCAP Core, or RPD. Each of these devices may run asynchronously with respect to each other.

The R-PHY functions themselves have stringent latency, jitter. This approach places no additional latency and/or jitter constraints on the CIN network, and places no synchronization/timing requirement between the CCAP Core and the RPD(s) it serves. The CIN network is effectively an additional IP "hop" (via L2TPv3 tunnel) between the head end devices and the Modulator/Demodulator functions.

¹² Added per R-00B-N-15.1399-3 on 1/8/15 by JB.

¹³ Revised per R-00B-N-15.1399-3 on 1/8/15 by JB.

7 R-OOB NARROWBAND ARCHITECTURE

This section defines the functionality required to support Out-Of-Band (OOB) signaling through an RPD by digitizing narrow portions of the spectrum. OOB signaling consists of any signals operating within the defined DOCSIS upstream and downstream spectrum that are not part of the DOCSIS specification.

Figure 15 shows the basic structure of an OOB system. In the forward direction, an OOB modulator device sends an analog signal into the CMTS. The CMTS samples the signal, packetizes the samples, and sends the samples through the CIN to the RPD. The RPD then converts the digitized spectrum back into the analog domain and sends them to the OOB CPE equipment. This process is called Narrowband Digital Forward (NDF). Likewise, in the reverse direction the OOB CPE equipment generates an analog signal which is then sampled by the RPD. The RPD packs the samples into packets and sends the packets through the CIN to the CMTS. The CMTS then converts the digitized spectrum back into an analog signal which is sent out to an OOB demodulator. This process is called Narrowband Digital Return (NDR).

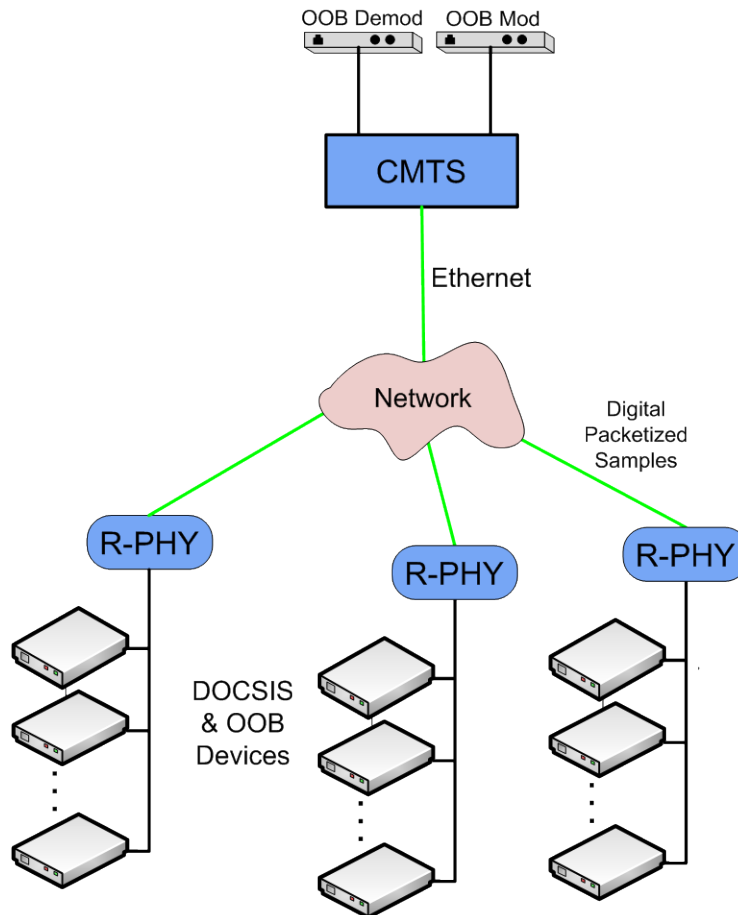

Figure 15 - NDF/NDR OOB Network Topology

7.1 Remote PHY Narrowband Digital Forward (NDF)

7.1.1 Overview

Remote PHY Narrowband Digital Forward (NDF) refers to the digitizing of an analog portion of the downstream spectrum at the headend, sending the digital samples as payload in [DEPI] packets to the RPD, and then re-creating the original analog stream at the RPD. A defined contiguous portion of spectrum, within which the OOB signals reside, is referred to here as an NDF channel.

The RPD **MUST** support a single NDF channel, but **MAY** support more than one NDF channels. The CMTS **MAY** support one or more NDF channels. The number of supported NDF channels will be identified via the RPD capabilities field.

Since the RPD plays out the samples into a D to A convertor as a continuous stream of samples, the samples provided by the CMTS cannot overflow or underrun the FIFOs in the RPD. As such, the CMTS and the RPD must remain frequency locked.

Table 20 provides a reference of common OOB signals which could be supported by NDF. The NDF specification uses these references to help identify the requirements.

Table 20 - Common Forward OOB Signals

DS OOB	DS Frequency Range	DS Channels
[SCTE 55-1]	70–130 MHz	1 x 1.8 MHz
[SCTE 55-2]	70–130 MHz	1 x 2.0 MHz
FM	87.5–108.0 MHz	-

7.1.2 NDF Channel Definition

The NDF channel is defined by a channel width and center frequency. In this context, the channel width refers to the total width of the spectrum including any required guardband. Table 21 shows the supported values for the NDF Channel. The RPD **MUST** support the NDF parameter requirements shown in Table 21. The CCAP Core **SHOULD** support the NDF parameter requirements shown in Table 21.

Table 21 - NDF Channel Parameters

Parameter	Value	RPD Support	CCAP Core Support
Channel Width	Symbol_Rate / 2 Annex A = ~2.5 MHz Annex B = 3.476 MHz	MUST	SHOULD
	Up to 25.6 MHz ¹	MAY	SHOULD
Center Frequency	70 – 130 MHz ²	MUST	SHOULD
Allocated Guardband	0.25 MHz	MUST	SHOULD
Sample Resolution	10-bits	MUST	SHOULD
1. To support the 20.5 MHz FM band, 87.5 to 108.0, 25.6 MHz of spectrum is required assuming 1.25x oversampling for guardband. This has been rounded down from 25.625 because the 25.6M Hz frequency is a convenient multiple of 5.12 MHz, and the extra 0.25 MHz of bandwidth should be easily recoverable from the guardband. 2. Center frequency is taken directly from the [SCTE 55-1] and [SCTE 55-2] requirements. FM requirements of 87.5 to 108.0 fall within this specification.			

The CCAP Core sends 10-bit I/Q symbols packed into [DEPI] frames. A separate NDF pseudowire is established in order to identify the characteristics of the NDF channel. Symbols are sent in I/Q pairs with the 10-bit I sample followed by the 10-bit Q sample. As shown in Figure 16, the symbols are carried in a DEPI PSP frame with no

segmentation. The CCAP Core MUST send an integral number of number of I/Q symbols in each L2TPv3 DEPI packet.

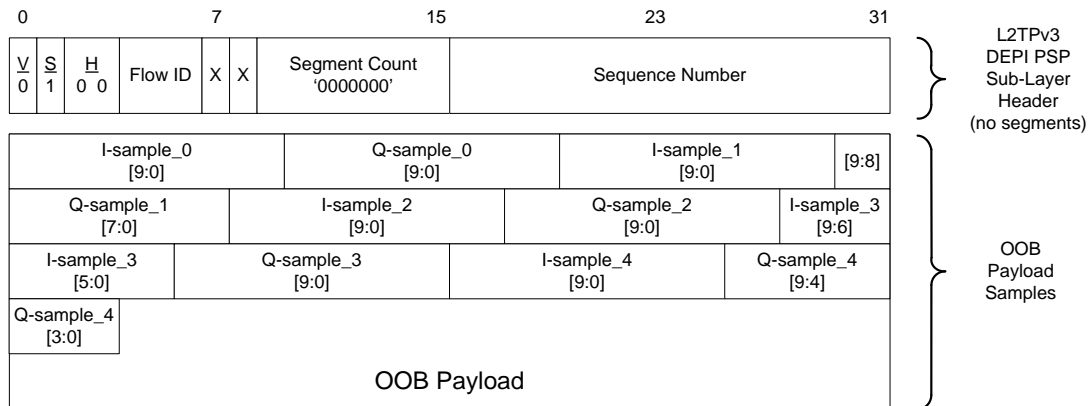

Figure 16 - PSP OOB Header Format

7.1.3 NDF Channel Rate

The I/Q symbols from the headend to the RPD are sent at baseband (i.e., the center frequency is '0' MHz). The symbol rate is equal to the width of the defined channel. For example, for a 2.5 MHz channel, symbols are sent at a rate of 2.5 Msymbols/s. Since a single symbol is represented by 20 bits, this translates into a link data rate of $(2.5 \text{ MS/s} \times 20 \text{ bits/S}) = 50 \text{ Mbps}$.

Because samples from the OOB modulator are condensed into a packet and then sent across a high speed link, there is some amount of latency associated with the process of packing symbols into the packet. Both the channel width and the packet size determine what this latency value is. For example, a 2.5 MHz channel will play out its samples at a rate of 2.5 Msymbols/s. If the CMTS were to send an MTU worth of data in the DEPI packet (i.e., ~1500 bytes), then the number of symbols that can be sent is $(1500 \text{ bytes} \times 8 \text{ bits/byte}) / 20 \text{ bits per symbol} = 600 \text{ symbols}$. The amount of time to send 600 symbols at a rate of 2.5 Msymbols/s is $(600 \text{ symbols} / 2.5 \text{ MS/s}) = 240 \text{ microseconds}$.

In addition to the packetization latency, the RPD's jitter buffer threshold value introduces latency. Using the previous example, if the jitter buffer's threshold is set to 150 microseconds, then an additional 150 microseconds is added to the 240 microsecond packetization latency for a total of 390 microseconds. Ultimately, the value of the RPD's jitter buffer threshold will be determined by the jitter contribution of both the CMTS and the network. For latency-sensitive applications, such as SCTE 55-2, latency can be reduced by using smaller packet sizes and/or by keeping the network between the CMTS and the RPD as simple as possible.

7.1.4 NDF Signal Processing Requirements

A CCAP Core that supports NDF MUST send 10-bit quadrature sampled I/Q symbols at baseband, and at a symbol rate equal to the specified channel width. Definition of the original carrier frequency of the signal or the signal processing chain in the CMTS is beyond the scope of this specification.

After reception, the samples received at the RPD need to be up-converted and then converted back to the analog domain. A guardband of 0.25 is provided for the DSP chain. This guardband allows for the DSP implementation of upsampling, or decimation filters. For example, if a passband of 2.0 MHz is required, then the required spectrum is $2.0 \text{ MHz} \times 1.25 = 2.5 \text{ MHz}$. The guardband is defined as the 250 kHz portion of the spectrum on either side of the usable 2.0 MHz. The OOB signal source SHOULD NOT have additional signals present within the guardband of the defined NDF channel.

The center frequency of the channel and the channel width are provided to the RPD when the NDF channel session is established. This specification does not dictate the specific DSP implementation for the up-conversion process, but it is required that the digital sample rate converters of the CMTS and RPD be phase locked. The required sampling rate is one half the DOCSIS downstream sampling rate. Higher sampling rates, and thus wider channels,

MAY be supported by the RPD up to 25.6 MHz. For higher sampling rates, the chosen rate MUST be selected such that a rational fractional number of symbols fits into an integer number of 10.24 MHz clocks. The fraction will be defined as M/N, and the CMTS is responsible to provide the M and N values to the RPD, when the NDF channel is established. The resulting symbol rate is referred to hereafter as the "passband symbol rate".

The act of down-conversion at the CMTS and up-conversion at the RPD can incorporate in-band energy from out-of-band frequencies, and can generate out-of-band spectral replications. As such, the spurious emissions and out-of-band noise requirements apply to the NDF channel.

7.2 Remote PHY Narrowband Digital Return (NDR)

7.2.1 Overview

Remote PHY Narrowband Digital Return (NDR) refers to the digitizing of an analog portion of the upstream spectrum at the RPD, sending the digital samples as payload in [R-UEPI] packets to the CMTS, and then re-creating the original analog stream at the headend. A defined contiguous portion of spectrum, within which the OOB signals reside, is called an NDR channel.

The RPD MUST support a single NDR channel. The RPD MAY support more than one NDR channel. The CMTS MAY support one or more NDR channels. The number of supported NDR channels is identified via the RPD capabilities field.

Since the headend must play out the digital samples at fixed rate, the rate of samples received from the RPD needs to match the CMTS rate such that the FIFO buffers in the CMTS do not overflow or underrun. Alternatively stated, the CMTS and the RPD must remain frequency locked.

Table 22 provides a list of common return OOB signals that could be supported by NDR. The Remote PHY NDR uses these references to help identify the requirements.

Table 22 - Common Return OOB Signals

US OOB	US Frequency Range	US Channels
[SCTE 55-1]	5–42 MHz	1 x 3.2 MHz 3 x 192 kHz
[SCTE 55-2]	8–26.5 MHz	1 x 2.0 MHz

7.2.2 NDR Channel Definition

The NDR channel is defined by a channel width and center frequency. Table 23 shows the supported values for the NDR channel. The RPD MUST support the NDR parameter requirements shown in Table 23. The CCAP Core SHOULD support the NDR parameter requirements shown in Table 23.

Table 23 - NDR Channel Parameters

Parameter	Value	RPD Support	CCAP Core Support
Channel Width	1.28, 2.56, or 5.12 MHz ¹	MUST	SHOULD
Center Frequency	5–26.5 MHz ²	MUST	SHOULD
Allocated Guardband	25%	MUST	SHOULD
Sample Resolution	10 bits	MUST	SHOULD
1. Defined channel widths based on the sampling rates in the DOCSIS upstream burst receivers. 2. Specified center frequencies are a subset of the center frequencies supported by [SCTE 55-1] and [SCTE 55-2].			

The RPD sends 10-bit I/Q symbols packed into [R-UEPI] frames. A separate NDR pseudowire is established in order to identify the characteristics of the NDR channel. Symbols are sent in I/Q pairs with the 10-bit I sample followed by the 10-bit Q sample. As shown in Figure 17, the symbols are carried in a UEPI PSP frame with no segmentation. The RPD MUST send an integral number of I/Q symbols in each L2TPv3 UEPI packet.

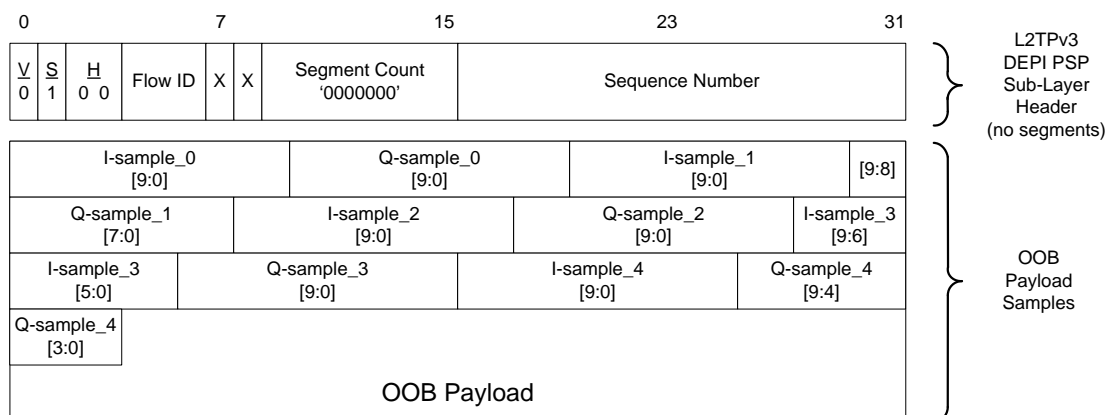

Figure 17 - PSP OOB Header Format

7.2.3 NDR Channel Rate

The I/Q symbols from the RPD to the headend are sent at baseband (i.e., the center frequency is '0' MHz). The symbol rate is equal to the width of the defined channel. For example, for a 5.12 MHz channel, symbols are sent at a rate of 5.12 Msymbols/s. Because a single symbol is represented by 20 bits, this translates into a link data rate of $(5.12\text{MSps} \times 20\text{ bps}) = 102.4\text{ Mbps}$.

Because symbols are condensed into a packet and then sent across a high speed link, there is some amount of latency associated with the process of packing symbols into the packet. Both the channel width and the packet size determine what this latency value is. For example, a 5.12 MHz channel will play out its samples at a rate of 5.12 Msymbols/s. If the CMTS were to send an MTU worth of data in the UEPI packet (i.e., ~1500 bytes), then the number of symbols that can be sent is $(1500\text{ bytes} \times 8\text{ bits/byte}) / 20\text{ bits per symbol} = 600\text{ symbols}$. The amount of time to send 600 symbols at a rate of 5.12 Msymbols/s is $(600\text{ symbols} / 5.12\text{MSPS}) = 117\text{ }\mu\text{seconds}$.

In addition to the packetization latency, the CMTS jitter buffer threshold value introduces latency. Using the previous example, if the jitter buffer's threshold is set to $1.5 \times 117\text{ }\mu\text{seconds} = 176\text{ }\mu\text{seconds}$, then an additional 176 $\mu\text{seconds}$ is added to the 117 μsecond packetization latency for a total of 293 $\mu\text{seconds}$. Ultimately, the value of the jitter buffer threshold in the CMTS will be determined by the jitter contribution of both the RPD and the network. For latency-sensitive applications, such as SCTE 55-2, latency can be reduced by using smaller packet sizes and/or by keeping the network between the CMTS and the RPD as simple as possible.

7.2.4 NDR Signal Processing Requirements

The RPD MUST down-convert the specified NDR channel from the specified center frequency to baseband, and provide 10-bit quadrature sampled I/Q symbols for the specified NDR channel. The I/Q symbol rate MUST be equal to the specified channel width. This specification does not define the detailed DSP methods used to down-convert the channel.

The I/Q symbol stream received by the CMTS is up-converted, converted back to the analog domain, and then sent to an OOB device at the headend. The DSP processing requirements of the symbols received by the headend is beyond the scope of this specification.

As shown in Table 23, the allowable channel widths have been restricted to fractions of the DOCSIS 10.24MHz clock in order to obviate the need for symbol rate conversion. A guardband of 0.25 is included in the channel width specification. Therefore, for example, a channel width of 5.12 MHz has a usable passband of 4.096 MHz

(4.096 MHz * 1.25 = 5.12 MHz). The guardband of 0.25 provides a reasonable compromise between filter complexity and bandwidth efficiency.

The act of down-conversion at the RPD can incorporate in-band energy from out-of-band frequencies. As such, spurious emissions and out-of-band noise requirements apply to the NDR channel. Specification of additional emissions caused by the act of up-conversion at the headend is beyond the scope of this document.

7.3 NDR/NDF Power Level and Digital Sample Representation

For each NDF channel, the RPD is configured with a target RMS output power level, P_{NDF} . For each NDR channel, the RPD is configured with a target RMS input power level, P_{NDR} . These values are expressed in dBmV.

The I and Q samples carried in NDF or NDR frames are represented as 10-bit values. The format of these values is s3.6 (i.e. one sign bit, three bits to the left of the binary point, and six bits to the right of the binary point). A complex RMS signal magnitude of 1.414 (i.e., $\sqrt{2}$) as expressed in s3.6 format corresponds to the commanded RMS output or input power level of the NDF or NDR signal.

For an NDF channel, an RPD MUST translate a stream of 10-bit digital samples with a complex RMS signal magnitude of $\sqrt{2}$ when the samples are interpreted in s3.6 format into an analog output signal with an RMS power of P_{NDF} (as configured for that channel). See also the accuracy requirements in Section 7.4.

For an NDR channel, an RPD MUST translate an input signal with an RMS power of P_{NDR} (as configured for that channel) into a stream of 10-bit digital samples with a complex RMS signal magnitude of $\sqrt{2}$ when the samples are interpreted in s3.6 format. See also the accuracy requirements in Section 7.4.

7.4 NDF/NDR Power Level Range and Performance Requirements

The RPD MUST support configured NDF power levels, P_{NDF} , which are within +3 to -12 dB of the highest power level configured on the same port for a single downstream SC-QAM channel.

The RPD MUST support configured NDR power levels, P_{NDR} , which are within +3 to -12 dB of the highest power level configured on the same port for a single upstream SC-QAM channel of the same width as the NDR channel.

The CCAP Core MUST NOT attempt to configure NDR/NDF power levels outside of the RPD's supported ranges.

The RPD MUST support a step size of 0.2 dB for configuration of NDR and NDF power levels.

The RPD MUST translate NDF digital samples into an analog output signal as described above with a power level accuracy of (TBD).

The RPD MUST translate analog input signals into NDR digital samples as described above with a power level accuracy of (TBD).

7.5 Networking Considerations

As shown in Figure 15, an OOB network consists of several elements. At the ends of the network are OOB modulators and demodulators in the headend, and CPE devices such as STBs on the other end. In between there is the CMTS, an Ethernet network, and the RPDs. Each of these devices can introduce latency and jitter in the OOB network.

The RPD MUST have sufficient NDF buffering to support the maximum network jitter as specified in [R-PHY]. The RPD MUST have a programmable jitter buffer threshold that can be adjusted to take advantage of lower network jitter.

The latency of the NDF and NDR paths through the RPD MUST NOT exceed 200 microseconds. This latency does not include latency induced by the jitter buffers or by the act of packetization.

The CMTS MUST have sufficient NDR buffering to support the maximum network jitter as specified in [R-PHY]. The CMTS MUST have a programmable jitter buffer threshold that can be adjusted to take advantage of lower network jitter.

The latency of the NDF and NDR paths through the CMTS device **MUST NOT** exceed 200 microseconds. This latency does not include latency induced by the jitter buffers or by the act of packetization.

NOTE: Some OOB protocols, such as [SCTE 55-2], require low latency. For these types of applications, it is the responsibility of the operator to ensure that the latency and/or jitter of the network is small enough to support the desired OOB application.

7.6 System Timing Considerations

The RPD **MUST** have sufficient NDF buffering to support the timing requirements specified in [R-DTI]. The CMTS **MUST** have sufficient NDR buffering to support the timing requirements specified in [R-DTI].

Appendix I SCTE 55-1 OOB System Notes (Informative)

I.1 OOB Delivery Overview

OOB data is used by set-top boxes on the cable plant for the delivery of data streams that support set-top box operation in the downstream and to convey responses and commands from the STB in the upstream. For SCTE 55-1 systems, an Out-of-Band Multiplexer/Modulator (OM) is used to create the OOB signal that is delivered to STBs via the HFC network. Upstream OOB data is destined for the Network Controller (NC), which processes the data and responds as appropriate.

OOB data comprises the following streams:

- EMM – Entitlement Management Message: Carries conditional access (CA) system data for use by the STB.
- Network: The Network PID carries the virtual channel map and the network information table (NIT).
- Code Download Images: Carries STB software updates and delivered as MPEG Programs within the OOB transport stream.
- PAT/PMT – Program Association Table/Program Map Table: Carries MPEG tables that identify programs available in the transport stream.
- Non-[SCTE 18] EAS – Emergency Alert System: Carries EAS messages to STBs that display on the user screen.
- Guide Data: Carries program details that are displayed in the schedule grid.
- Interactive Data: Carries data that is used in interactive applications on the STB.

I.1.1 OOB Delivery in Headends Today

Today, these streams are multiplexed by an Out-of-band Multiplexer/Modulator (OM) as specified in [SCTE 55-1], creating MPEG transport streams that are carried via a QPSK channel and transmitted at a specific RF frequency into the headend combining network, typically 75.25 MHz or 104.25 MHz (frequency depends on system and CPE). This RF signal is combined with EQAM /CCAP downstream signals for transmission on the cable plant. Each OM outputs a single OOB signal to the CIN; in some larger implementations, more than one OM may be required to create unique OOB signals for different populations. The RF OOB signals are converted to optical signals and sent via AM laser to the appropriate node, which converts it back into RF-modulated electrical signals and transmits them on the downstream HFC plant.

Upstream OOB signals—primarily polling and interactive application signals—are sent upstream by the STB. These signals are handled in one of two ways:

- The upstream RF signals are received at the fiber node and are converted to analog optical signals. The optical signals are transmitted to the headend via analog laser. At the headend, an analog receiver converts the upstream optical signal to RF and splits out the upstream OOB signals (based on frequency), delivering to a return path demodulator. The return path demodulator converts the RF to IP packets and forwards the resulting packets to an NC.
- The upstream RF signals are received at the fiber node and are converted to digital signals. The digital signal is transmitted upstream to the headend, where it is received by an upstream receiver that converts the signal to RF. The OOB RF signal is delivered to a return path demodulator. The return path demodulator converts the RF to IP packets and forwards the resulting packets to an NC.

There may be more than one return path demodulator and NC in a given headend, but there is always a many-to-one relationship between return path demodulators and their NC. Routing the correct feeds from the appropriate fiber nodes is performed in the combining/splitting network in the headend.

I.2 SCTE 55-1 OOB System Components

The various streams, their sources, and their transmission paths are illustrated in Figure 18. Although not depicted, OM A and OM B both receive source OOB streams.

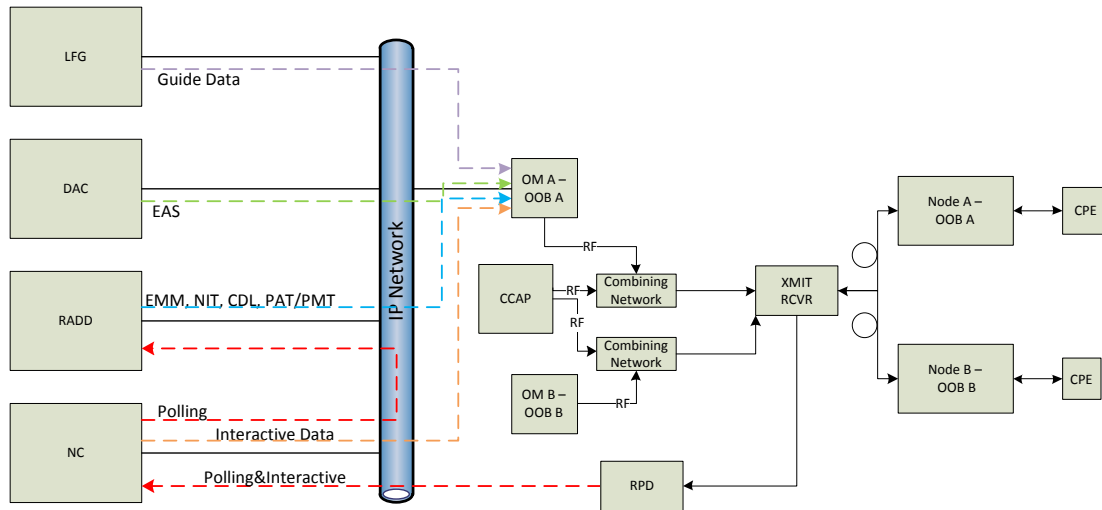

Figure 18 - Traditional OOB Transmission

The network components depicted here have the following functions:

- LFG – Live Feed Generator: Provides guide data for STB consumption.
- DAC – Digital Addressable Controller: Builds EAS messages for consumption by the OM.
- RADD – Remotely Addressable DANIS and DLS: Provides MPEG data necessary for video operation.
- NC – Network Controller: Provides data for interactive applications and responds to messages from STBs in the plant.
- OM – Out-of-Band Modulator: Per [SCTE 55-1], receives data streams for the OOB channel, processes them into MPEG transport streams and QPSK modulates an RF signal that is transmitted into the headend combining network.
- Combining Network – Takes RF signals from various network components and combines them into a single downstream RF signal.
- XMIT/RCVR – Forward Lasers and Receive Modules: The forward lasers convert RF electrical signals to optical signals and transmit to the fiber node. The receive modules receive convert optical signals to RF signals and transmit into the plant combining and splitting network. Upstream OOB signals are split out by frequency and sent to the return path demodulator.
- RPD – Return Path Demodulator: Receives RF modulated MPEG transport streams, demodulates the signal, and sends the MPEG packets to the NC via IP.

Appendix II SCTE 55-2 System Notes (Informative)

The [SCTE 55-2] R-OOB Remote PHY architecture is best understood through examination and comparison to existing system deployments.

Figure 19 depicts a legacy (pre Remote PHY) end-to-end SCTE 55-2 system level deployment.

A SCTE 55-2 Controller Client/Server IP connection is used to manage operations of the SCTE 55-2 Modulator/Demodulator as a single entity which is serving 5K to 10K two-way DHCTs. Most relevant is that today's Modulator/Demodulator is addressed on a distinct "management IP" subnet (independent of the subnet used to communicate with the various DHCTs).

The external world communicates with DHCTs through a distinct "DHCT IP" subnet. The subnet may be fairly large (capable of supporting up to 16K DHCTs). Each SCTE 55-2 Modulator/Demodulator manages routing within its own distinct subnet – each DHCT is assigned an IP address from this subnet.

The SCTE 55-2 Mod/Demod delivers two different "types" of information from the outside world to the DHCTs. *Video Control Data* is information delivered to the DHCT to enable the video/service offerings. As shown in Figure 19, this information may be delivered in IP unicast or multicast form to the SCTE 55-2 Modulator/Demodulator. Regardless of the unicast/multicast IP delivery method used, the SCTE 55-2 Mod/Demod maps this data onto VPI/VCI channels that deliver the content to a broad range of DHCTs (even though it was delivered in IP unicast format to the SCTE 55-2 Mod/Demod). DHCTs have ability to filter content appropriately.

The second type of information is *DHCT Application Data* (see Figure 19). This data is delivered via "unicast" VPI/VCI channels to unique DHCT destinations and is processed by the IP stack on the DHCT. With this method a full unicast IP stack capability is enabled on the DHCT. Additionally, IP broadcast packets addressed to the subnet may be forwarded via an IP Broadcast VPI/VCI tunnel so that all DHCTs can receive IP broadcast packets.

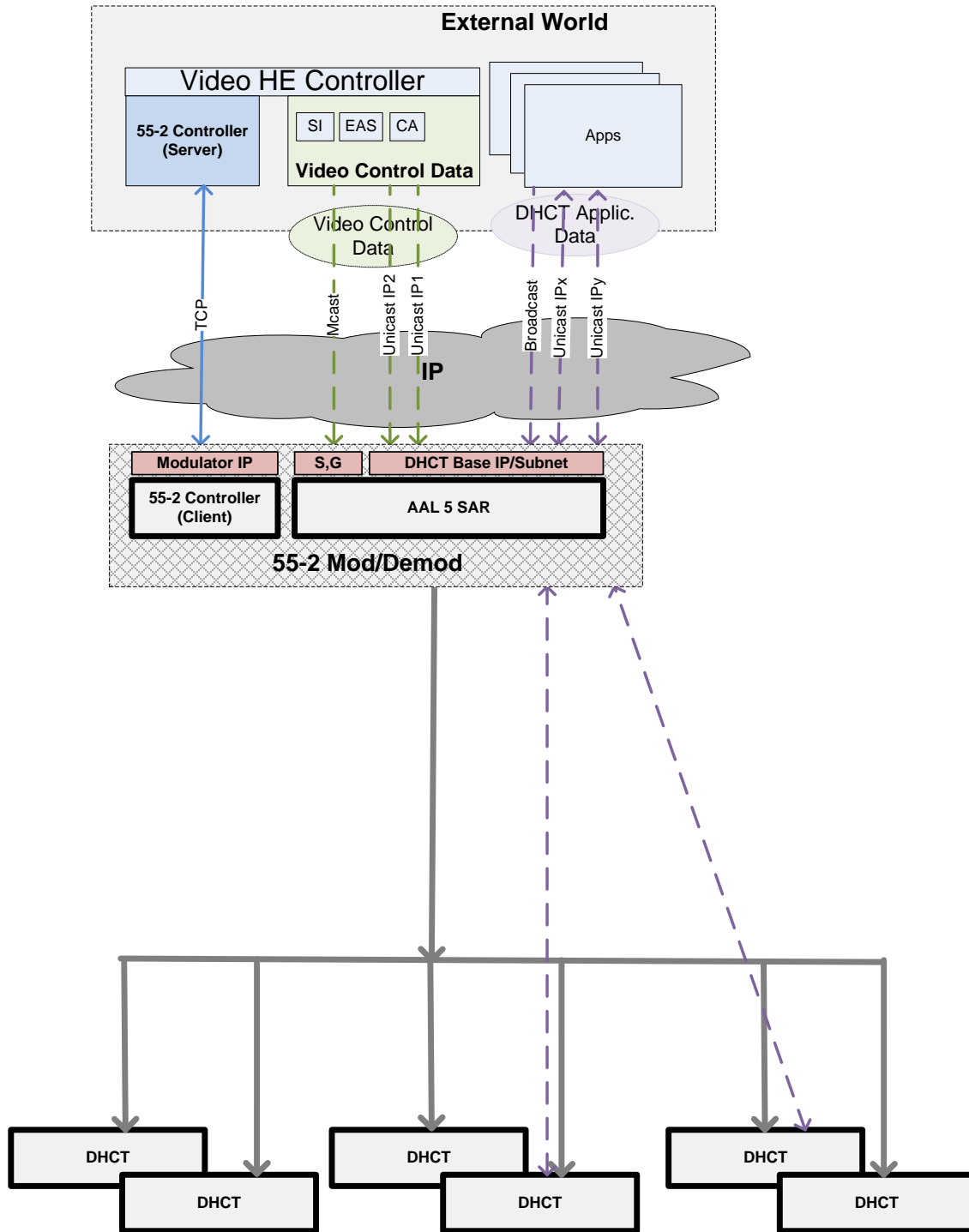

Figure 19 - Legacy SCTE 55-2 System Deployment Architecture

Appendix III Acknowledgements

On behalf of the cable industry and our member companies, CableLabs would like to thank the following individuals for their contributions to the development of this specification:

Contributor	Company Affiliation
Steve Foley	Arris
Niki Pantelias	Broadcom
Dave Fox	Casa Systems
John T. Chapman	Cisco
Don Strausberger	Cisco
Bill Wall	Cisco
Douglas Will	Comcast
Kerry Hjertaas	Vecima
Colin Howlett	Vecima
Douglas Johnsom	Vecima

On behalf of the cable industry and our member companies, CableLabs would like to thank the following individuals for their contributions to the development of the technology and participation in the Remote PHY Working Group.

Contributor	Company Affiliation	Contributor	Company Affiliation
Bill Powell	Alcatel-Lucent	Saifur Rahman	Comcast
Brian Kurtz	Altera	Jorge Salinger	Comcast
Carlton Lane	Analog	Joe Solomon	Comcast
Linda Mazaheri	Analog	Douglas Will	Comcast
Tom Ferreira	Arris	Jeff Ford	Complex IQ
Steve Foley	Arris	Al Garrett	Complex IQ
Anand Goenka	Arris	Ony Anglade	Cox Communications
Jeff Howe	Arris	Mike Cooper	Cox Communications
Hari Nair	Arris	Samir Parikh	Gainspeed Networks
Andrew Chagnon	Broadcom	João Campos	Get
Victor Hou	Broadcom	Even Kristoffersen	Get
Niki Pantelias	Broadcom	Adi Bonen	Harmonic
David Pullen	Broadcom	Mike Patrick	Harmonic
Stuart Hoggan	CableLabs	Jim Chen	Huawei
Volker Leisse	CableLabs	Hesham ElBakoury	Huawei
Karthik Sundaresan	CableLabs	Karl Moerder	Huawei
Nikhil Tayal	CableLabs	Jack Moran	Huawei
Jun Tian	CableLabs	Guangsheng Wu	Huawei
Andrew Sundelin	CableLabs Consultant	Phil Oakley	LGI
Naor Goldman	Capacicom	Stan Bochenek	Maxim Integrated
Dave Fox	Casa Systems	Ajay Kuckreja	Maxim Integrated
Maike Geng	Casa Systems	Len Dauphinee	MaxLinear
David Claussen	Charter	David Huang	MaxLinear
Nobo Akiya	Cisco	Louis Park	MaxLinear
Alon Bernstein	Cisco	Sridhar Ramesh	MaxLinear
Brian Bresnahan	Cisco	Patrick Tierney	MaxLinear
John T. Chapman	Cisco	Scott Walley	MaxLinear
Hang Jin	Cisco	Rei Brockett	Pace/Aurora

Contributor	Company Affiliation	Contributor	Company Affiliation
Tong Liu	Cisco	Nasir Ansari	Rogers
Carlos Pignataro	Cisco	George Hart	Rogers
Sangeeta Ramakrishnan	Cisco	Kevin Kwasny	Shaw
John Ritchie	Cisco	Lee Johnson	ST Micro
Pawel Sowinski	Cisco	Paul Brooks	Time Warner Cable
Don Strausberger	Cisco	Kirk Erichsen	Time Warner Cable
Yi Tang	Cisco	Kerry Hjertaas	Vecima
Bill Wall	Cisco	Colin Howlett	Vecima
Gerry White	Cisco	Douglas Johnson	Vecima
Philippe Perron	Cogeco	Faten Hijazi	Xilinx
John Bevilacqua	Comcast	Alex Luccisano	Xilinx
Nagesh Nandiraju	Comcast		

Additionally, CableLabs would like to thank the DCA MSO team for their continued support in driving the specification development and the decision-making process.

Karthik Sundaresan, CableLabs

Appendix IV Revision History

IV.1 Engineering Changes for CM-SP-R-OOB-I02-160121

ECN	Date Accepted	Summary	Author
R-OOB-N-15.1399-3	12/16/2015	RPHY SCTE 55-1	Foley
R-OOB-N-15.1402-2	12/16/2015	RPHY SCTE 55-2	Howlett
