

Data-Over-Cable Service Interface Specifications

DCA - MHA v2

Modular Headend Architecture v2 Technical Report

CM-TR-MHA v2-V01-150615

RELEASED

Notice

This DOCSIS® technical report is the result of a cooperative effort undertaken at the direction of Cable Television Laboratories, Inc. for the benefit of the cable industry and its customers. You may download, copy, distribute, and reference the documents herein only for the purpose of developing products or services in accordance with such documents, and educational use. Except as granted by CableLabs® in a separate written license agreement, no license is granted to modify the documents herein (except via the Engineering Change process), or to use, copy, modify or distribute the documents for any other purpose.

This document may contain references to other documents not owned or controlled by CableLabs. Use and understanding of this document may require access to such other documents. Designing, manufacturing, distributing, using, selling, or servicing products, or providing services, based on this document may require intellectual property licenses from third parties for technology referenced in this document. To the extent this document contains or refers to documents of third parties, you agree to abide by the terms of any licenses associated with such third-party documents, including open source licenses, if any.

© Cable Television Laboratories, Inc. 2014-2015

DISCLAIMER

This document is furnished on an "AS IS" basis and neither CableLabs nor its members provides any representation or warranty, express or implied, regarding the accuracy, completeness, noninfringement, or fitness for a particular purpose of this document, or any document referenced herein. Any use or reliance on the information or opinion in this document is at the risk of the user, and CableLabs and its members shall not be liable for any damage or injury incurred by any person arising out of the completeness, accuracy, or utility of any information or opinion contained in the document.

CableLabs reserves the right to revise this document for any reason including, but not limited to, changes in laws, regulations, or standards promulgated by various entities, technology advances, or changes in equipment design, manufacturing techniques, or operating procedures described, or referred to, herein.

This document is not to be construed to suggest that any company modify or change any of its products or procedures, nor does this document represent a commitment by CableLabs or any of its members to purchase any product whether or not it meets the characteristics described in the document. Unless granted in a separate written agreement from CableLabs, nothing contained herein shall be construed to confer any license or right to any intellectual property. This document is not to be construed as an endorsement of any product or company or as the adoption or promulgation of any guidelines, standards, or recommendations.

Document Status Sheet

Document Control Number:	CM-TR-MHAv2-V01-150615			
Document Title:	Modular Headend Architecture v2 Technical Report			
Revision History:	V01 - 06/15/2015			
Date:	June 15, 2015			
Status:	Work in Progress	Draft	Released	Closed
Distribution Restrictions:	Author Only	CL/Member	CL/Member/Vendor	Public

Trademarks

CableLabs® is a registered trademark of Cable Television Laboratories, Inc. Other CableLabs marks are listed at <http://www.cablelabs.com/certqual/trademarks>. All other marks are the property of their respective owners.

Table of Contents

1	INTRODUCTION	7
1.1	Remote PHY Defined	7
1.2	Evolution of Remote PHY	8
1.3	Digital HFC	8
1.4	Summary.....	9
2	INFORMATIVE REFERENCES	10
2.1	Reference Acquisition.....	11
3	TERMS AND DEFINITIONS	12
4	ABBREVIATIONS AND ACRONYMS.....	13
5	MHA TECHNOLOGY (MODULAR CMTS)	15
5.1	Overview	15
5.2	DEPI.....	15
5.2.1	<i>D-MPT Pseudowire</i>	16
5.2.2	<i>PSP Pseudowire</i>	17
6	MHAV2/REMOTE PHY TECHNOLOGY	18
6.1	Overview	18
6.2	R-PHY Deployment Model	19
6.3	R-PHY Specifications and Applications.....	20
6.3.1	<i>R-PHY Pseudowire</i>	21
6.3.2	<i>UEPI</i>	21
6.3.3	<i>R-DTI</i>	21
6.3.4	<i>R-OOB</i>	22
7	NEW PROTOCOL EXTENSIONS	23
7.1	Packet Length	23
7.2	MPLS.....	23
7.3	MCM: Multi-Channel MPT	23
7.4	BFD	24
7.5	DOCSIS 3.1 Support	25
7.5.1	<i>DS OFDM Channel Pseudowire</i>	25
7.5.2	<i>DS PLC Channel Pseudowire</i>	25
7.5.3	<i>DOCSIS 3.1 Upstream Pseudowires</i>	26
7.6	Video	26
7.7	OOB.....	26
7.8	NDF/NDR.....	27
8	REMOTE PHY TIMING.....	28
8.1	R-DTI - One-Way Reverse	28
8.2	R-DTI - Two-Way Reverse	29
8.3	R-DTI - Two-Way Forward.....	29
8.4	Remote Scheduler.....	30
8.5	Details about Timing	30
8.5.1	<i>Packet Formats</i>	30
8.5.2	<i>Support for DTP</i>	30
8.5.3	<i>Distances</i>	30
9	GCP GENERIC CONTROL PLANE.....	31
9.1	Tunneling Data Structures from Another Protocol.....	31

9.2	Master and Slave.....	31
9.3	RPD Configuration via GCP.....	32
APPENDIX I ACKNOWLEDGEMENTS		33

List of Figures

Figure 1 - MHAv2 Reference Architecture for DOCSIS Signaling and Provisioning	7
Figure 2 - MHA System Diagram	15
Figure 3 - DEPI Pseudowire Format.....	15
Figure 4 - D-MPT Pseudowire Type	16
Figure 5 - PSP Pseudowire Type.....	17
Figure 6 - Remote PHY System Architecture.....	18
Figure 7 - Remote PHY Signaling.....	18
Figure 8 - MHAv2 Reference Architecture for Remote PHY	19
Figure 9 - Remote PHY Deployment Model	20
Figure 10 - Remote PHY Pseudowire.....	21
Figure 11 - UEPI Pseudowire	21
Figure 12 - DEPI over MPLS	23
Figure 13 - DEPI MPT/MCM Pseudowire	24
Figure 14 - DEPI or UEPI with BFD.....	24
Figure 15 - DOCSIS 3.1 UEPI Pseudowires	26
Figure 16 - R-DTI One-Way Reverse.....	28
Figure 17 - R-DTI Two-Way Reverse	29
Figure 18 - R-DTI Two-Way Forward	29
Figure 19 - GCP Block Diagram	31

List of Tables

Table 1 - Applications and Transports.....	20
--	----

This page left blank intentionally.

1 INTRODUCTION

Remote PHY (R-PHY) is a next step in the progressive evolution of DOCSIS technology and video service delivery. It is a modification of the current CCAP (Converged Cable Access Platform) architecture in which the PHY component is removed from the CCAP platform and relocated into a separate Remote PHY Device (RPD). Remote PHY refers to the technique of moving the Physical Layer (PHY) circuit out of a device such as a CCAP and putting the PHY circuit at the edge of a network. Remote PHY builds upon the work started with Modular CMTS (M-CMTS) and Modular Headend Architecture (MHA) at CableLabs.

Remote PHY is an evolving set of specifications and products that make up the next version of Modular Headend Architecture (MHAv2). This technical report focuses on the expanded definition and the updates to the transport and timing for Remote PHY and how they apply to DOCSIS, MPEG-TS video, and out-of-band signaling for set-top boxes.

1.1 Remote PHY Defined

Remote PHY is an architectural strategy that removes the PHY element from a CMTS/CCAP platform and places that PHY element in a separate access point that is interconnected with an IP network (even simple Metro Ethernet networks or EPONs qualify, since they use IP packets). This arrangement is shown in Figure 1.

Restated, the Remote PHY architecture allows a main chassis at one end of a network and the PHY ASIC/Module at the other end of the network. This is a useful technique when the PHY chip needs to be close to an access network, but the desire is to put the intelligence and complexity in a central location that has more room and is more serviceable.

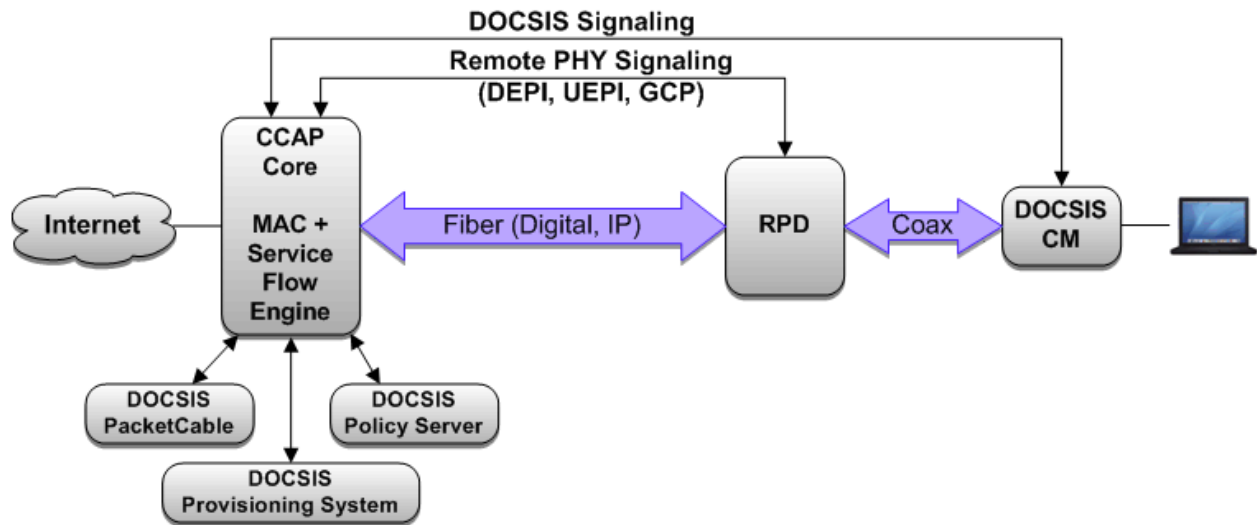

Figure 1 - MHAv2 Reference Architecture for DOCSIS Signaling and Provisioning

Remote PHY implies centralized software. The least amount of complexity is placed remotely; the most amount of complexity is retained centrally. This approach helps maximize up-time by making the network more reliable.

Remote PHY-like strategies (similar in concept but different in implementation) have been used in adjacent markets such as:

- Wi-Fi access points
- LTE access points
- Ethernet over coax (EoC)
- EPON over coax (EPoC)
- xDSL

Remote PHY in this context was applied initially to a DOCSIS CMTS. Now, the Remote PHY architecture is also being applied to traditional MPEG-TS video and to out-of-band (OOB) signaling.

1.2 Evolution of Remote PHY

The first instance of distributing the CMTS functionality was the Modular CMTS (M-CMTS) specifications from CableLabs circa 2005. At that time, the specifications included:

- [DEPI] - DOCSIS External PHY Interface
- [DTI] - DOCSIS Timing Interface
- [ERMI] - Edge Resource Management Interface
- [M-OSSI] - M-CMTS Operations Support System Interface Specification

These specifications were targeted at combining CMTS Downstream PHY Layer and Edge QAMs (EQAMs) together into one system. While the original intent was to lower the system cost, the real benefit ended up being the ability to greater customize the CMTS for cost and performance.

At the time, another specification was created but was not standardized, because there was no market application for it. That specification was:

- [R-UEPI] - Upstream External PHY Interface

UEPI builds upon the DEPI pseudowire concepts and applies them to the upstream CMTS MAC-PHY interface. In 2006, UEPI was used as a MAC-to-PHY interface within vendor silicon implementations for I-CMTS applications.

In 2008, a second round of specifications that focused on the EQAM was published. Because the specifications now referred to more than just the CMTS, they were renamed as the Modular Headend Architecture (MHA) specifications. These specifications included:

- [EQAM-PMI] - Edge QAM Provisioning and Management Interface
- [EQAM-VSI] - Edge QAM Video Stream Interface
- [MHA-TR] - MHA Technical Report

In 2012, the Chinese national regulatory body for the cable industry known as SARFT (State Administration of Radio, Film, and Television) adopted Remote PHY (DEPI and UEPI) as C-DOCSIS (China DOCSIS) Type III.

1.3 Digital HFC

One of the operational goals of the Remote PHY architecture is to put R-PHY technology into an optical node in a Hybrid Fiber Coax (HFC) plant. This would allow the fiber portion of the HFC plant to become digital. To date, the HFC forward path has used analog optics, and the reverse path has used both analog and digital optics.

The conversion of the HFC plant from a linear optics plant to a digital optics plant could be achieved anytime the plant is to be segmented or upgraded. The most compelling case is deep fiber. Today's plant is typically N+5, which refers to an optical node plus five amplifiers in cascade after the node. A deep fiber plant design would be N+0 or N+1, meaning an optical node plus no more than one amplifier.

In a deep fiber plant, there are many more optical nodes, headend optical lasers and receivers, as well as CMTS ports that need to be installed.

Digital forward and reverse paths are compelling for both technical and strategic reasons. The technical reasons are:

- Longer distances (80+ km vs. 40 km)
- More wavelengths (80 vs. 16)
- Lower cost optics (based upon 10G Ethernet)
- Higher throughput (more bits per hertz) if the DOCSIS 3.1 PHY segment is located after the coax segment
- Lower maintenance costs
- Improved reliability

If the digital fiber is also an IP network (or Metro Ethernet or EPON/GPON network), then these additional strategic benefits need to be considered:

- Compatibility with digital access networks which are now appearing internationally.
- The technology scales well for deep fiber applications.
- The same IP-based access network can be used for residential and commercial use.
- The same IP-based access network can be used to support DOCSIS (with Remote PHY) and Fiber to the Home (FTTH).

1.4 Summary

The benefits of R-PHY can be summarized as follows:

- Remote PHY is an approach that takes the PHY chip out of a CMTS box and puts it at the edge of an IP network. One of the principles of Remote PHY is to put the least amount of hardware and software at the end point and keep the complexity centralized.
- Remote PHY implies control by centralized DOCSIS software. This allows the same software model to be used for I-CCAP and Remote PHY CCAP. Remote PHY, I-CMTS and M-CMTS can all co-exist in the same chassis and use the same software base and configuration systems. This is a very powerful concept for feature velocity and backwards compatibility.
- Remote PHY works and works well. The Remote PHY architecture is built on top of open standards such as Ethernet, IP, L2TPv3, and CableLabs MHA.
- Remote PHY will allow CCAP devices to be deployed in creative installations such as using digital fiber in the HFC plant. For cable operators, this will allow their network to have higher performance with lower OPEX, lower CAPEX, and an evolutionary path to FTTH.

2 INFORMATIVE REFERENCES

This technical report uses the following informative references. References are either specific (identified by date of publication, edition number, version number, etc.) or non-specific. For a non-specific reference, the latest version applies.

- [DEPI] DOCSIS Downstream External PHY Interface Specification, CM-SP-DEPI-I08-100611, June 11, 2010, Cable Television Laboratories, Inc.
- [DTI] DOCSIS Timing Interface Specification, CM-SP-DTI-I06-150305, March 5, 2015, Cable Television Laboratories, Inc.
- [EQAM-PMI] Edge QAM Provisioning and Management Interface Specification, CM-SP-EQAM-PMI-I02-111117, November 17, 2011, Cable Television Laboratories, Inc.
- [EQAM-VSI] Edge QAM Video Stream Interface Specification, CM-SP-EQAM-VSI-I01-081107, November 7, 2008, Cable Television Laboratories, Inc.
- [ERMI] DOCSIS Edge Resource Manager Interface Specification, CM-SP-ERMI-C01-140520, May 20, 2014, Cable Television Laboratories, Inc.
- [GCP] Generic Control Plane Specification, CM-SP-GCP-I01-150615, June 15, 2015, Cable Television Laboratories, Inc.
- [IEEE 1588] IEEE-1588-2008, IEEE Standard for a Precision Clock Synchronization Protocol for Networked Measurement and Control Systems, July 2008, <http://standards.ieee.org/findstds/standard/1588-2008.html>
- [MHA-TR] Modular Headend Architecture Technical Report, CM-TR-MHA-V02-081209, December 9, 2008, Cable Television Laboratories, Inc.
- [M-OSSI] DOCSIS Modular Operations Support System Interface Specification, CM-SP-M-OSSI-I08-081209, December 9, 2008, Cable Television Laboratories, Inc.
- [MULPIv3.1] DOCSIS MAC and Upper Layer Protocol Interface Specification, CM-SP-MULPIv3.1-I06-150611, June 11, 2015, Cable Television Laboratories, Inc.
- [R-DEPI] Remote Downstream External PHY Interface Specification, CM-SP-R-DEPI-I01-150615, June 15, 2015, Cable Television Laboratories, Inc.
- [R-DTI] Remote DOCSIS Timing Interface Specification, CM-SP-R-DTI-I01-150615, June 15, 2015, Cable Television Laboratories, Inc.
- [R-OOB] Remote Out-of-Band Specification, CM-SP-R-OOB-I01-150615, June 15, 2015, Cable Television Laboratories, Inc.
- [R-PHY] Remote PHY Specification, CM-SP-R-PHY-I01-150615, June 15, 2015, Cable Television Laboratories, Inc.
- [R-UEPI] Remote Upstream External PHY Interface Specification, CM-SP-R-UEPI-I01-150615, June 15, 2015, Cable Television Laboratories, Inc.
- [RFC 3931] IETF RFC 3931, Layer Two Tunneling Protocol - Version 3 (L2TPv3), March 2005.
- [RFC 5880] IETF RFC 5880, Bidirectional Forwarding Detection (BFD), June 2010.

- [RFC 5881] IETF RFC 5881, Bidirectional Forwarding Detection (BFD) for IPv4 and IPv6 (Single Hop), June 2010.
- [RFC 5885] IETF RFC 5885, Bidirectional Forwarding Detection (BFD) for the Pseudowire Virtual Circuit Connectivity Verification (VCCV), June 2010.
- [SCTE 55-1] ANSI/SCTE 55-1 2009, Digital Broadband Delivery System: Out of Band Transport Part 1: Mode A.
- [SCTE 55-2] ANSI/SCTE 55-2 2008, Digital Broadband Delivery System: Out of Band Transport Part 2: Mode B.

2.1 Reference Acquisition

- Cable Television Laboratories, Inc., 858 Coal Creek Circle, Louisville, CO 80027; Phone +1-303-661-9100; Fax +1-303-661-9199; <http://www.cablelabs.com>
- Internet Engineering Task Force (IETF) Secretariat, 48377 Fremont Blvd., Suite 117, Fremont, California 94538, USA, Phone: +1-510-492-4080, Fax: +1-510-492-4001, <http://www.ietf.org>
- SCTE, Society of Cable Telecommunications Engineers Inc., 140 Philips Road, Exton, PA 19341; Phone: +1-610-363-6888 / 800-542-5040; Fax: +1-610-363-5898; <http://www.scte.org/>

3 TERMS AND DEFINITIONS

This document uses the following terms:

Cable Modem (CM)	A modulator-demodulator at subscriber locations intended for use in conveying data communications on a cable television system.
CCAP-Core	A CCAP device that uses MHAv2 protocols to interconnect to an RPD.
Edge QAM modulator (EQAM)	A headend or hub device that receives packets of digital video or data. It re-packetizes the video or data into an MPEG transport stream and digitally modulates the digital transport stream onto a downstream RF carrier using quadrature amplitude modulation (QAM).
Media Access Control (MAC)	Used to refer to the Layer 2 element of the system which would include DOCSIS framing and signaling.
Out-of-Band	Signaling channel that is used to control set-top boxes.
Pseudowire	IP tunnel between two points in an IP network.
Remote PHY Device	The Remote PHY Device (RPD) is a device in the network that implements the Remote-PHY/MHAv2 specifications to provide conversion from digital Ethernet transport to analog RF transport.
Remote PHY pseudowire	A set of pseudowires that carries data between the CCAP-Core and the RPD in both directions.
Remote PHY System	An approach to DOCSIS framing and signaling that takes the PHY chip out of a CMTS box and puts it at the edge of an IP network.
YANG	A modeling language developed by the IETF.

4 ABBREVIATIONS AND ACRONYMS

This document uses the following abbreviations:

ASIC	Application-Specific Integrated Circuit
ATM	Asynchronous Transfer Mode
BFD	Bi-directional Forwarding Detection
CAPEX	Capital expenditures
CCAP™	Converged Cable Access Platform
CCF	Continuous Concatenation and Fragmentation
CIN	Converged Interconnect Network
CM	Cable Modem
CMTS	Cable Modem Termination System
CRC	Cyclic Redundancy Check
DCA	Distributed CCAP Architecture
DEPI	Downstream External PHY Interface
DLM	DEPI Latency Measurement
DLS	DOCSIS Light Sleep
D-MPT	DOCSIS MPEG Transport Pseudowire
DRFI	[DOCSIS] Downstream Radio Frequency Interface [Specification]
DS	Downstream
DTI	DOCSIS Timing Interface
DTP	DOCSIS Timing Protocol
EQAM	Edge-QAM (modulator)
FTTH	Fiber to the Home
GCP	Generic Control Plane
HA	High Availability
HMAC	Keyed-Hash Message Authentication Code
I-CMTS	Integrated Cable Modem Termination System
IETF	Internet Engineering Task Force
IKEv2	Internet Key Exchange version 2
IP	Internet Protocol
IPv4	Internet Protocol version 4
IPv6	Internet Protocol version 6
L2TPv3	Layer Two Tunneling Protocol version 3
LDP	Label Distribution Protocol
LDPC	Low-Density Parity Check
MAP	Upstream Bandwidth Allocation Map (referred to only as MAP)

MB	Message Block
MCM	Multi-Channel MPT
M-CMTS	Modular Cable Modem Termination System
MHA	Modular Headend Architecture
MPLS	Multiple Protocol Label Switching
MPT	MPEG Transport (see also D-MPT)
MPTS	MPEG Transport Stream
NDF	Narrowband Digital Forward
NDR	Narrowband Digital Return
NETCONF	Network Configuration Protocol
OFDM	Orthogonal Frequency Division Multiplexing
OPEX	Operational expenditures
PCR	Program clock reference
PHY	Physical Layer
PID	Packet Identifier used in MPEG-TS
PLC	PHY Link Channel
PSP	Packet Streaming Protocol
PW	Pseudowire
RDC	Regional Data Center
R-DTI	Remote DOCSIS Timing Interface
R-OOB	Remote Out-of-Band
RPD	Remote PHY Device
R-PHY	Remote PHY
S-BFD	Seamless Bidirectional Forwarding Detection
SNMP	Simple Network Management Protocol
SPTS	Single Program Transport Stream
SyncE	Synchronous Ethernet
TCP	Transmission Control Protocol
TWTT	Two-Way Time Transfer
UDP	User Datagram Protocol
UEPI	Upstream External PHY Interface
US	Upstream

5 MHA TECHNOLOGY (MODULAR CMTS)

5.1 Overview

The central, headend part of the access network, for the Modular Headend Architecture, is shown in Figure 2.

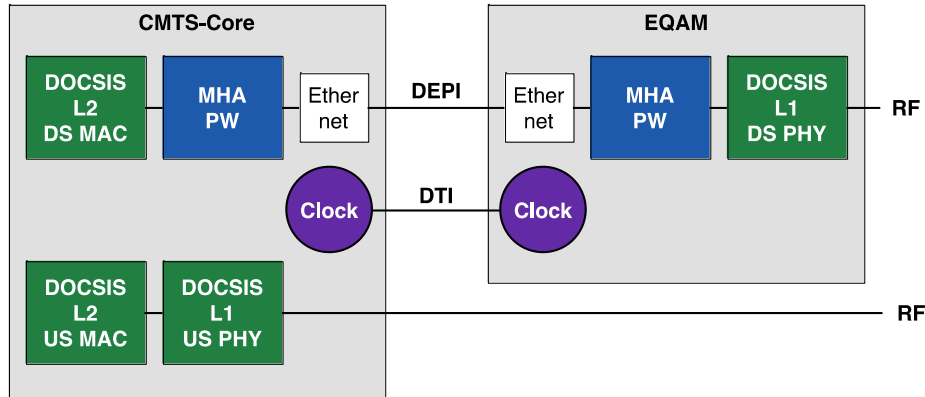

Figure 2 - MHA System Diagram

In a current MHA system, the downstream DOCSIS PHY is located externally in an EQAM while the upstream DOCSIS PHY remains in the CMTS Core. The interface for the downstream PHY is Downstream External PHY Interface (DEPI).

5.2 DEPI

In an Integrated CMTS (I-CMTS) system, DEPI can be the interface between the MAC chip and the PHY chip. In an MHA system, DEPI is the protocol interface between the MAC interface in the CMTS Core and the PHY chip in the EQAM Device.

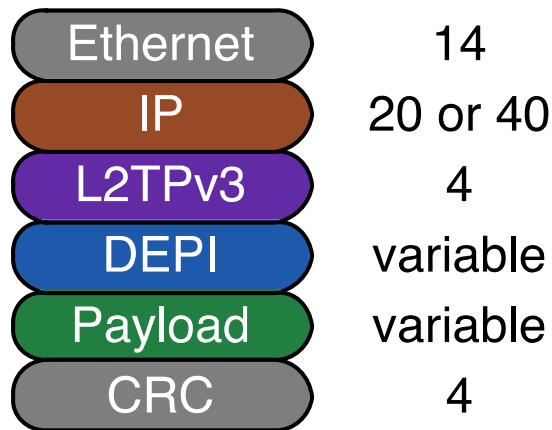

Figure 3 - DEPI Pseudowire Format

DEPI is the Downstream External PHY Interface. In a Remote PHY system, DEPI is the protocol interface between the MAC interface in the CCAP-Core and the PHY chip in the Remote PHY Device.

The general pseudowire format for DEPI along with the corresponding byte count is shown in Figure 3. The sub-elements of the DEPI packet are as follows:

- Ethernet header
- IPv4 or IPv6 header
- L2TPv3 header
- DEPI header
- DEPI payload
- CRC

The first three headers are well-defined by IEEE and IETF specifications. The published version of DEPI includes an optional UDP header ahead of the L2TPv3 header. This option is not used in practice.

The L2TPv3 header contains a single 32-bit session ID. If the session ID is all zeros, the packet is a control plane packet. If the session ID is non-zero, then it is a data packet. The control plane associates a session ID with a pseudowire type and subtype. The base L2TPv3 protocol is defined in [RFC 3931].

The DEPI header also specifies the format of the DEPI payload. There are two DEPI pseudowire types.

- D-MPT, which is the DOCSIS MPEG transport pseudowire
- PSP, which is the Packet Streaming Protocol pseudowire

Each pseudowire can have a subtype. Examples of subtype are “DOCSIS 3.0 Downstream” and “DOCSIS 3.1 Downstream”. The pseudowire type is part of the normal L2TPv3 control plane, and the pseudowire subtype is advertised in the DEPI-specific extensions.

5.2.1 D-MPT Pseudowire

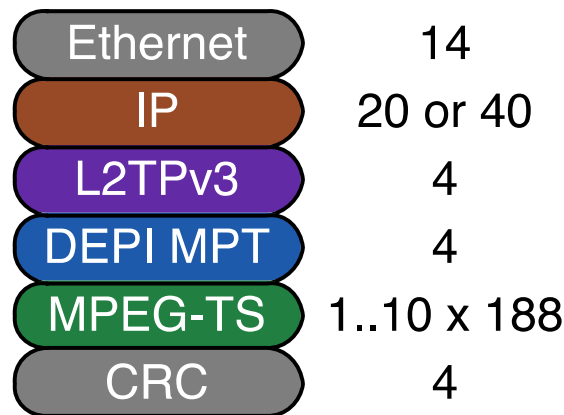

Figure 4 - D-MPT Pseudowire Type

The DOCSIS MPEG-TS pseudowire is the only pseudowire that was deployed in DOCSIS 3.0-based M-CMTS systems. As the name implies, the DEPI header is followed by a number of 188 byte MPEG-TS packets. For M-CMTS, the DEPI packet size limited the number of MPEG-TS packets to seven while for Remote PHY, it has been increased to ten.

The D-MPT header is 32 bits in size and contains the basic DEPI header that is used in all the pseudowire types. It includes:

- A V bit to permit L2TPv3 payload multiplexing within an L2TPv3 session.
- An S bit to indicate if the sequence field is valid.
- Two H bits that allow DEPI payload multiplexing within a DEPI session. This is used for DLM, the DEPI latency measurement packet.
- Three-bit flow ID. Used for indicating the QoS of the payload.
- Segment count for PSP.

- Sequence number for the pseudowire session.

The V bit, S bit, and the sequence number are recommended fields from L2TPv3. All the other fields are DEPI-specific.

5.2.2 PSP Pseudowire

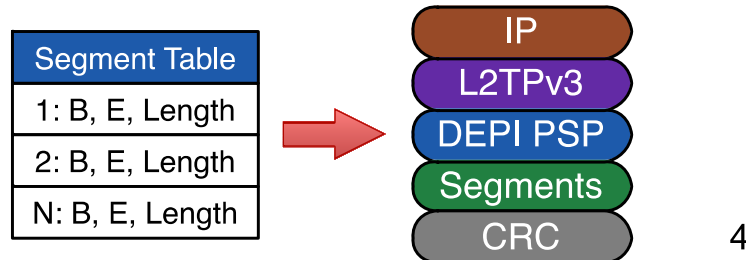

Figure 5 - PSP Pseudowire Type

The PSP pseudowire has a payload that is divided into one or more segments. Packets are mapped to segments. A segment can contain the beginning, middle, or end of a packet. Payload packets can be split across multiple DEPI packets. Unlike continuous concatenation and fragmentation (CCF) from DOCSIS 3.0, a segment cannot contain the end of one packet and the beginning of the next.

The basic PSP pseudowire subtype only places packets in the segments. In other subtypes, segments can be used to carry pre-pended or post-pended information that is per packet.

The PSP pseudowire header uses the same 32-bit header from D-MPT, plus it adds a segment table. The segment table contains one entry for each segment present in the payload. The entries contain:

- Begin bit
- End bit
- Segment length

The “begin” and “end” bits are used for packet reassembly. The segment length is used to find the next segment start byte.

PSP allows different packet flows, such as MAP traffic, to be placed into different pseudowires and be given different QoS characteristics.

6 MHAV2/REMOTE PHY TECHNOLOGY

Remote PHY technology builds upon the original [DEPI] specification.

6.1 Overview

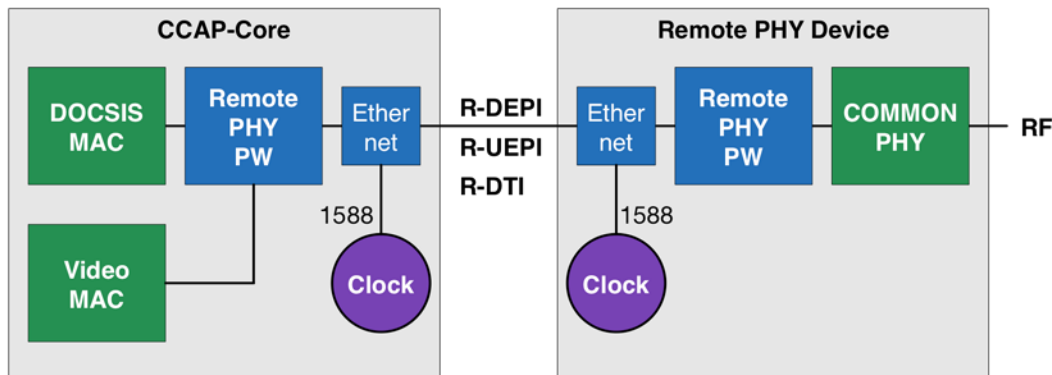

Figure 6 - Remote PHY System Architecture

A Converged Cable Access Platform (CCAP) is a combination of a DOCSIS Cable Modem Termination System (CMTS) and an Edge QAM (EQAM).

An Integrated CCAP (I-CCAP) has the CMTS and EQAM in one chassis. In a Remote PHY system, the PHY circuitry from the I-CMTS is removed and put into the Remote PHY Device. The remaining parts of the CCAP are called the CCAP-Core. This is shown in Figure 6.

Note that hybrid approaches are equally valid. A CCAP system could have both integrated MAC-PHY line cards and MAC-only line cards that support Remote PHY.

The Remote PHY protocols use the concept of a pseudowire (PW). A pseudowire is just a name for an IP tunnel between two points in an IP network. Pseudowires take a specific packet from one point on an IP network and move it to another point. In the case of Remote PHY, pseudowires are used to move MPEG-TS packets and DOCSIS frames between the MAC and the PHY.

One of the significant properties of the Remote PHY protocols is that it is an IP packet that can traverse any kind of network. It can traverse a Layer 2 forwarding network, a Layer 3 routed network, or even an MPLS network.

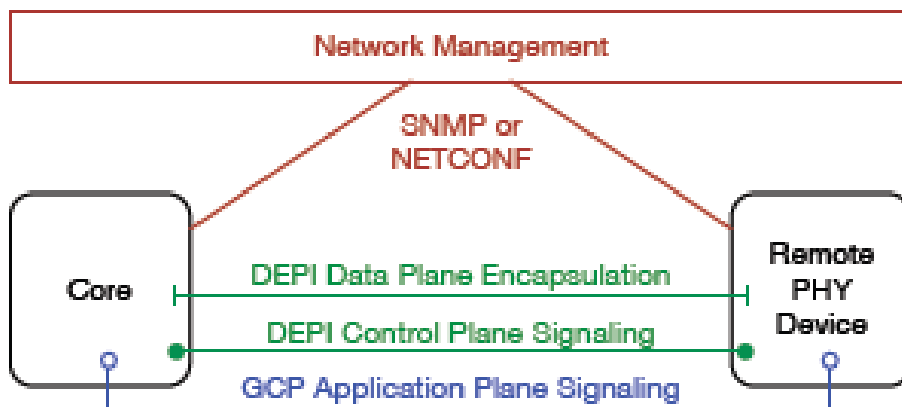

Figure 7 - Remote PHY Signaling

The R-PHY architecture uses a set of standardized protocols for its operation, as illustrated in Figure 7. The pseudowires (IP tunnels) between the Core and the Remote PHY Device are managed with a protocol called R-DEPI (Remote Downstream External PHY Interface). An extension to DEPI is R-UEPI (Remote Upstream External PHY Interface). R-DEPI is based on the IETF protocol L2TPv3 (Layer 2 Tunneling Protocol version 3). The R-DEPI control plane is used for session establishment and tear down and to manage failovers for HA (High Availability). The R-DEPI data plane also includes S-BFD (Seamless Bidirectional Forwarding Detection) to perform data plane diagnostics. R-DEPI supports DOCSIS, Video, and OOB (Out of Band)—all using the same techniques and protocols.

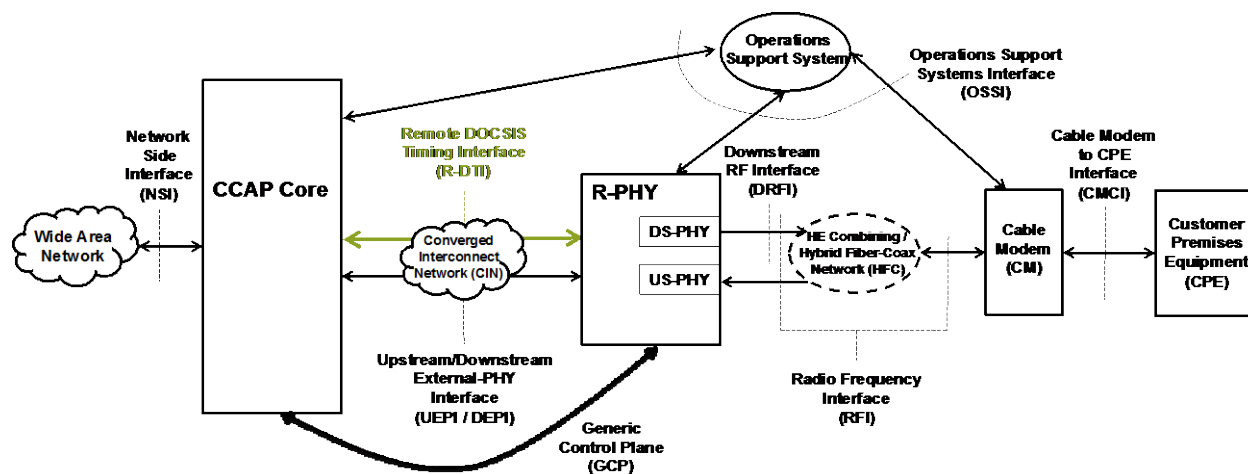

Figure 8 - MHAv2 Reference Architecture for Remote PHY

To program the ASICs and their corresponding functionality within the RPD, a separate protocol called GCP (Generic Control Plane) protocol is used. GCP is a protocol shim that carries application specific data elements, such as TLVs (type-length-value tuples), over the GCP shim, using a transport such as TCP. All components are also manageable through SNMP or similar evolved network management protocols such as NETCONF/YANG.

6.2 R-PHY Deployment Model

A reference model for a typical MSO's plant is shown in Figure 9. A regional data center (RDC) is connected to multiple headends over a regional backbone network. The headends in turn are connected to multiple distribution hubs over a regional access network. Both the regional backbone and the regional access networks are typically IP/Ethernet networks running over a digital optical transport. The distribution hubs are connected to optical nodes over the optical access network.

Historically, the optical access network has been an analog network but in an R-PHY deployment it can also be IP/Ethernet over digital fiber. From the optical nodes, coaxial cable carries an analog signal link to the cable modem at the subscriber's premise. In this reference architecture, the return path fiber from the optical node terminates at the hub. For this reason, the I-CCAP has been located in the hub.

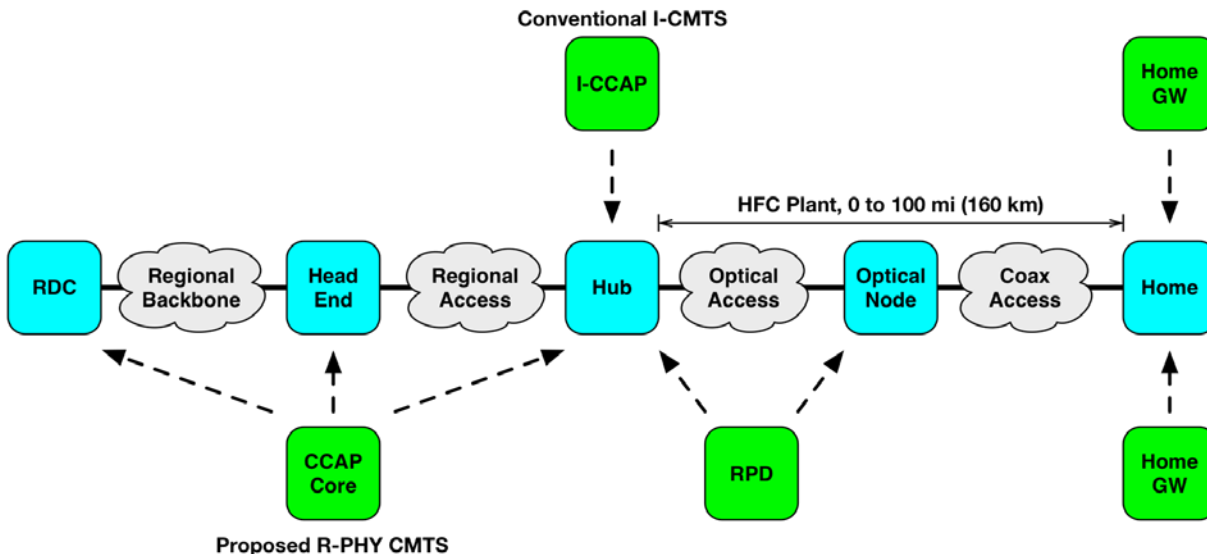

Figure 9 - Remote PHY Deployment Model

In some systems where the hub has multiplexed and transported the return path fiber to the headend, the I-CCAP can be located at the headend. However, in this technical report, we will refer to the I-CMTS location as being at the hub. One distinct advantage of the R-PHY architecture is that it removes the distance limitations imposed by the analog link and could in theory enable the CCAP core to be located in a regional data center thousands of kilometers from the CM. Thus, R-PHY enables the CCAP-Core to be located in the RDC, headend, or hub. Similarly the RPD can be located in the hub or at an optical node.

6.3 R-PHY Specifications and Applications

Table 1 - Applications and Transports

Transport	Application		
	DOCSIS	Video	OOB
DEPI	Yes	Yes	Yes
UEPI	Yes	No	Yes
R-DTI	Yes	No	Yes

Table 1 shows the basic transports and timing used in R-PHY and how three different applications or higher layer protocols are mapped to these transports. Each of the transports and applications will be described in subsequent subsections.

6.3.1 R-PHY Pseudowire

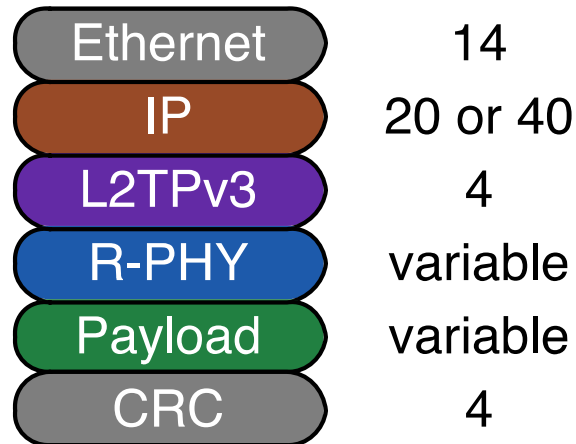

Figure 10 - Remote PHY Pseudowire

The generic Remote PHY pseudowire is the same as the MHA DEPI pseudowire except that it has many more subtypes. In MHA DEPI, there are just the D-MPT and PSP pseudowire types. R-PHY now has a collection of subtypes that add extensions to D-MPT and PSP.

6.3.2 UEPI

UEPI is the Upstream External PHY Interface. UEPI is new for Remote PHY and was not part of the original M-CMTS and MHA specifications.

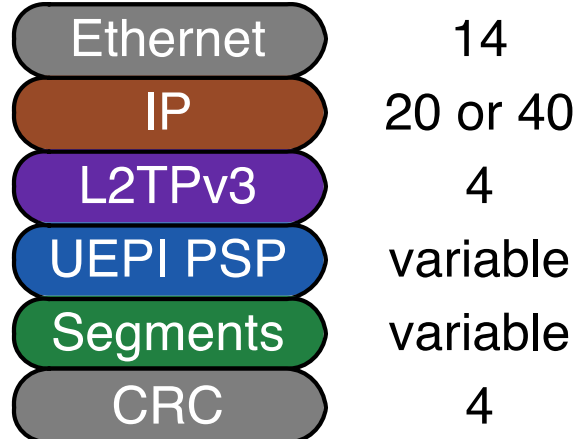

Figure 11 - UEPI Pseudowire

UEPI is an extension to L2TPv3 (see [RFC 3931]). UEPI uses the PSP pseudowire type from DEPI and uses the same control plane as DEPI. UEPI has unique pseudowire types for the upstream direction that are explained in Section 7.5.3.

6.3.3 R-DTI

[R-DTI] is the Remote DOCSIS Timing Interface. The local version, just known as DTI, is part of the M-CMTS specifications. The original DTI protocol defines how a timing server can provide timing to a CMTS Core and an EQAM and how both devices can have the same timestamp. The DTI protocol is described in [DTI].

6.3.4 R-OOB

R-OOB is Remote Out-of-Band. OOB is the signaling channel in the downstream and upstream that is used to control set-top boxes (STBs).

R-OOB uses DEPI and UEPI so that the pseudowires can be set up and torn down with the same control plane protocols as the rest of the Remote PHY pseudowires. [R-OOB] is a separate specification because it is a distinct and potentially separate application.

7 NEW PROTOCOL EXTENSIONS

7.1 Packet Length

DEPI was originally defined with a 1500-byte Ethernet packet. In D-MPT mode, this allows for up to seven MPEG-TS packets per DEPI packet. In this version of the Remote PHY specifications, that length is increased to approximately 2000 bytes. This allows up to 10 MPEG-TS packets per DEPI packet.

7.2 MPLS

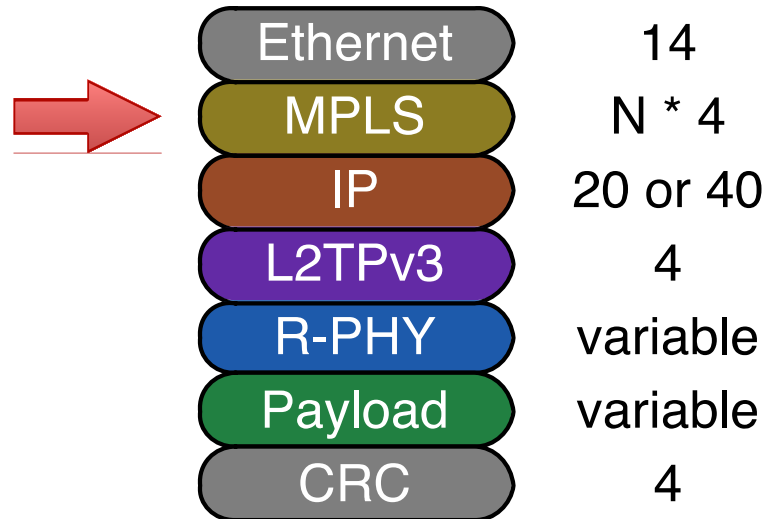

Figure 12 - DEPI over MPLS

MPLS (Multiple Protocol Label Switching) is a method of moving packets across a network using labels that can be popped on and off at each network forwarding point. MPLS routes are set up using LDP. MPLS routes are calculated using protocols such as MPLS Traffic Engineering (MPLS-TE).

The two underlying types of pseudowires used in a Layer 2 network are MPLS and L2TPv3. The MPLS pseudowire is used for native MPLS networks, and the L2TPv3 pseudowire is used for native IP networks. Each protocol has its own control plane. If DEPI had been originally designed as an MPLS pseudowire, it would have added protocol extensions to MPLS-TE.

Since DEPI is IP-packet based, it can be sent over any type of network, including an MPLS network. Since the DEPI control plane is already well-defined and working, the working group has chosen not to rebuild DEPI with MPLS-TE. Instead, the DEPI forwarding plane and control plane will remain as L2TPv3 and will (optionally) run on top of MPLS. This is shown in Figure 12.

To summarize, DEPI does not use an MPLS pseudowire. DEPI uses an L2TPv3-based pseudowire that can be run over an MPLS network.

7.3 MCM: Multi-Channel MPT

MCM is a subtype of the main MPT pseudowire. MCM uses a table in the DEPI header that lists which MPEG-TS packet in the DEPI payload goes to which QAM channel. A table format in the header is used rather than tagging each MPEG-TS packet so that the table can be read once and then executed multiple times against the rest of the packet. This is shown in Figure 13.

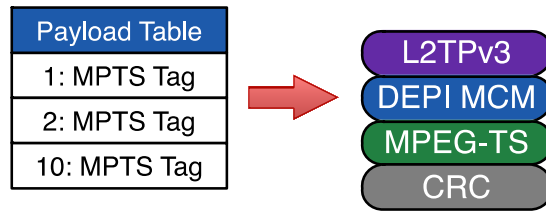

Figure 13 - DEPI MPT/MCM Pseudowire

As currently defined, there is one DEPI pseudowire for each QAM channel in the Remote PHY. The advantage of MPEG Transport (MPT) is that it provides a simple point-to-point connection from a MAC channel to a PHY channel. The disadvantage is that additional latency is incurred in building up MPEG-TS packets into a DEPI packet. The latency of 10 MPEG-TS packets at 1 Gbps is 1.6 μs.

While this is not much latency, MCM also offers an improvement by allowing multiple QAM channels to share the same pseudowire. This helps with scaling. For example, instead of having 160 pseudowires for 160 QAM channels, theoretically there could be one really busy DEPI pseudowire. In actual practice, there would be a smaller number of DEPI pseudowires, each with a number of QAM channels.

Note that while any number of QAM channels can be supported within a pseudowire, each DEPI packet can only contain up to 10 MPEG-TS packets in one packet.

7.4 BFD

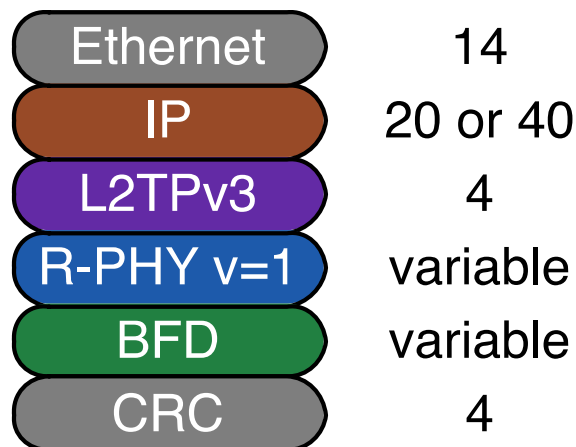

Figure 14 - DEPI or UEPI with BFD

BFD refers to Bi-directional Forwarding Detection. BFD is essentially a loopback packet that can be used for testing data path integrity. By integrating BFD directly into the packet, the entire transmission path from the DOCSIS MAC channel to the Remote PHY QAM channel can be tested.

Note that BFD can also be sent in a standalone UDP packet. BFD is an industry standard extension to L2TPv3 and applies to all DEPI and UEPI pseudowire types and subtypes. BFD is described in [RFC 5880], [RFC 5881], and [RFC 5885].

7.5 DOCSIS 3.1 Support

DOCSIS 3.1 is a new version of DOCSIS that has recently been released by CableLabs. DOCSIS 3.1 uses a new physical layer based on Orthogonal Frequency Division Multiplexing (OFDM) and an error correction scheme called Low Density Parity Check (LDPC). The data path consists of one or more OFDM channels. Each OFDM channel has a PHY Link Channel (PLC) for initializing CMs.

In DOCSIS 3.1, the downstream OFDM channel is assigned a list of profiles. The profile lists the modulation to be used for each subcarrier in an OFDM channel. The profile can be different for each LDPC block and depends on which CM is receiving the OFDM block. DOCSIS 3.1 was designed this way to allow the optimization of the transmission path to those CMs that can tolerate a higher order modulation.

The PLC is composed of message blocks (MB). The following message blocks are defined in DOCSIS 3.1:

- Timestamp MB
- DLS (DOCSIS Light Sleep Mode) MB
- Trigger MB
- Message Channel MB
- Null MB

The Trigger MB is generated locally at the Remote PHY Device. The other MBs are transparently passed from the CCAP-Core to the Remote PHY Device.

In DOCSIS 3.1, the downstream and upstream frequency ranges can be altered to provide more throughput. DOCSIS 3.1 can scale to support 1–2.5 Gbps in the upstream, and 5–10 Gbps in the downstream.

7.5.1 DS OFDM Channel Pseudowire

Each OFDM channel is assigned to a PSP pseudowire with a subtype of DOCSIS 3.1 data path. The PSP header is extended so that its table contains the OFDM profile number for each packet in the PSP stream.

7.5.2 DS PLC Channel Pseudowire

Each PLC is assigned to a PSP pseudowire with a subtype of PLC. For the DLS MB, Trigger MB, and the Null MB, the MBs are placed directly into a PSP segment and referenced by the PSP table. A 32-bit timestamp can optionally be prepended to a segment. This is useful for the trigger MB. The packets in the payload of the message channel are mapped to PSP segments.

7.5.3 DOCSIS 3.1 Upstream Pseudowires

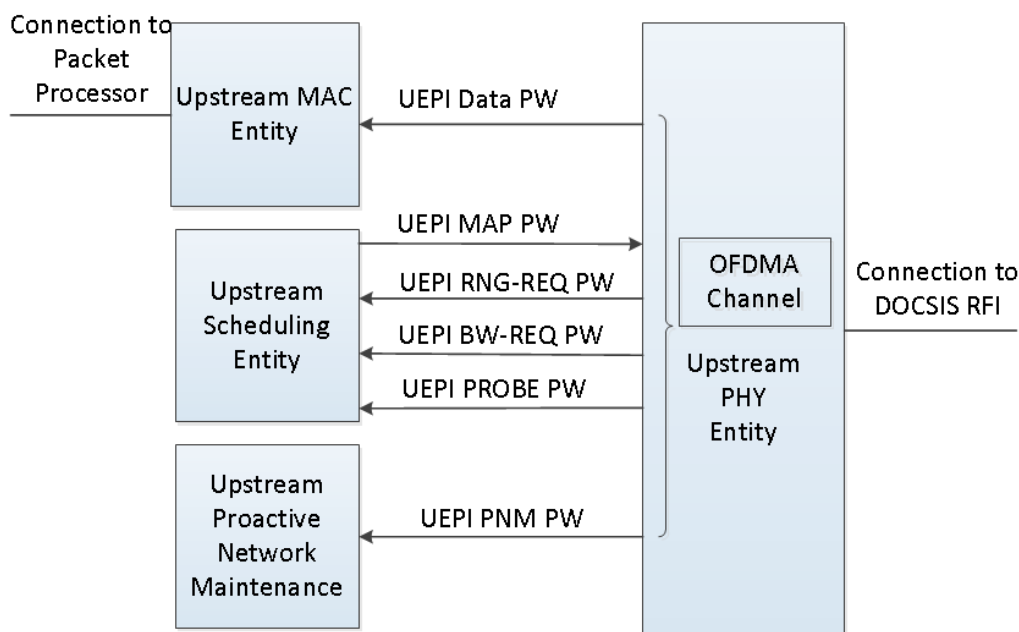

Figure 15 - DOCSIS 3.1 UEPI Pseudowires

There are a number of pseudowires associated with the DOCSIS 3.1 upstream. All pseudowires have a pseudowire type of PSP and each has a unique subtype. The DOCSIS 3.1 UEPI pseudowires are similar to the DOCSIS 3.0 UEPI pseudowires, but have differences in formats. The probe pseudowire is unique to DOCSIS 3.1 Remote PHY.

7.6 Video

For video, the same Remote PHY philosophy that was used for a DOCSIS CMTS is applied to a video EQAM. This works extremely well now that both the CMTS and EQAM functionalities are contained in the same CCAP device and use the same PHY chip.

The video in the form of SPTS or MPTS is received by the CCAP-Core from the network. The CCAP-Core performs all the same EQAM functions that it normally performs. These include a jitter buffer with PCR re-stamping, SPTS assembly into MPTS, conditional access, PID remapping, etc.

The resulting fully formatted MPTS stream is then sent over a DEPI pseudowire to the Remote PHY Device. Because the network between the CCAP-Core and the Remote PHY Device will introduce some jitter, the Remote PHY needs to contain a second smaller video jitter buffer. This jitter buffer can be smaller than the one in the CCAP-Core because it does not need to filter server jitter.

Since video is already in MPEG-TS format, video can be sent using a variant of the MPT/MPT and MPT/MCM pseudowires. The variation is that an MPEG-TS packet counter is added to the L2TPv3 sequence counter. The additional MPEG-TS packet counter helps in error recovery.

7.7 OOB

OOB refers to the out-of-band protocols that control set-top box operation. There are two main OOB systems in use and they are defined in SCTE specifications:

- [SCTE 55-1]: This is the Motorola/Arris system that uses MPEG-TS packets in the downstream and an Aloha polling system in the upstream.
- [SCTE 55-2]: This is the Scientific Atlanta/Cisco system that uses ATM over a modified T1 frame.

Analysis shows that the [SCTE 55-1] system could be implemented using the pure Remote PHY strategy. However, the [SCTE 55-2] system has a 3 ms turnaround time from upstream to downstream that would have made it extremely sensitive to network latency. As a result, the decision was made to include the OOB framer along with the OOB PHY pseudowire in the Remote PHY Device. All the signaling for OOB and the carousel generation would remain centralized.

This also allows the OOB system to be driven directly by provisioning systems and OOB controllers independent of the CCAP-Core if so desired.

OOB would use a dedicated DEPI and UEPI pseudowire so that the links between the CCAP-Core and the RPD can be reconfigured in conjunction with the other links for DOCSIS and video.

There are many approaches to passing OOB signals through a Remote PHY system. Each approach differs in the functionality hosted on the CCAP-Core, constraints/capacities/demands placed on the CIN, and functionality placed in the R-PHY.

The 55-1 and 55-2 systems are fundamentally different in that the 55-2 system includes a scheduled TDMA upstream that is intolerant of packet network latency/jitter and does not include provisions of equivalent "map advance" DOCSIS features to compensate. The 55-1 system does not include such upstream scheduling capabilities (and timing/jitter constraints), however requires multiple upstream frequencies to operate.

Three approaches that are specified for MHAv2/R-PHY architecture are as follows:

- 55-2 R-PHY solution serves to replace the existing 55-2 modulator/demodulator hardware and RF combining circuitry deployed in legacy headends with small-scale 55-2 modulator/demodulator functions embedded in each RPD.
- 55-1 R-PHY solution serves to utilize existing 55-1 modulator functionality (packet-based output instead of RF output) in the downstream, and place upstream demodulator and reassembly functions in the RPD.
- Narrowband Digital Forward (NDF) and Narrowband Digital Return (NDR) digitizes a small portion of the spectrum, and sends the digital samples as payload within packets which traverse between the CMTS and the Remote PHY. This approach works with any type of OOB signal as long as the signal can be contained within the defined pass bands.

The 55-2 R-PHY and 55-1 R-PHY solutions are targeted specifically at supporting legacy Set-top Box (STB) equipment which employs either [SCTE 55-1] or [SCTE 55-2] PHY layer signaling. This approach requires that the Remote PHY has specific knowledge of the protocols so that it can de-modulate/modulate the OOB data, and perform some portion of the MAC layer processing of this data.

7.8 NDF/NDR

The Remote PHY specifications include a narrowband digital forward and reverse path. NDF and NDR permit a small amount of spectrum to be transparently passed between the CCAP-Core and the HFC spectrum. This can be used as an alternative to a discrete OOB implementation, or to pick up unaccounted-for features such as a pilot tone.

NDF operates at 130 MHz and below with a bandwidth of 25 MHz or less. NDR operates at 42 MHz and below with a bandwidth of 10 MHz or less.

Remote PHY Narrowband Digital Forward (NDF) refers to the digitizing of an analog portion of the downstream spectrum at the headend, sending the digital samples as payload in DEPI packets to the R-PHY, and then re-creating the original analog stream at the Remote PHY. A defined contiguous portion of spectrum, within which the OOB signals reside, is referred to as an NDF channel.

Remote PHY Narrowband Digital Return (NDR) refers to the digitizing of an analog portion of the upstream spectrum at the Remote PHY, sending the digital samples as payload in UEPI packets to the CMTS, and then re-creating the original analog stream at the headend. A defined contiguous portion of spectrum, within which the OOB signals reside, is referred to as an NDR channel.

8 REMOTE PHY TIMING

Timing in a Remote PHY Network is managed with the Remote DTI ([R-DTI]) protocol. DTI is a timing protocol between a cable converged access platform core function (CCAP-Core) and a series of remote physical Layer devices (Remote PHY Device or RPD) that enables the RPD to support DOCSIS/video/out-of-band (OOB) services.

One goal of R-DTI is to get approximately the same timestamp value in the CCAP-Core and the Remote PHY. However, the technology for R-DTI is completely different than the technology used for DTI. Only the name is similar. Whereas DTI is a local protocol that runs over a maximum distance of 200 meters from DTI server to DTI client, R-DTI is required to work over long distances.

The R-DTI specification specifies multiple modes of operation that provide different levels of performance. There is a simple one-way and two-way option where the Remote PHY Device is clock master and a complete [IEEE 1588] mode where the Remote PHY Device is a clock slave.

8.1 R-DTI - One-Way Reverse

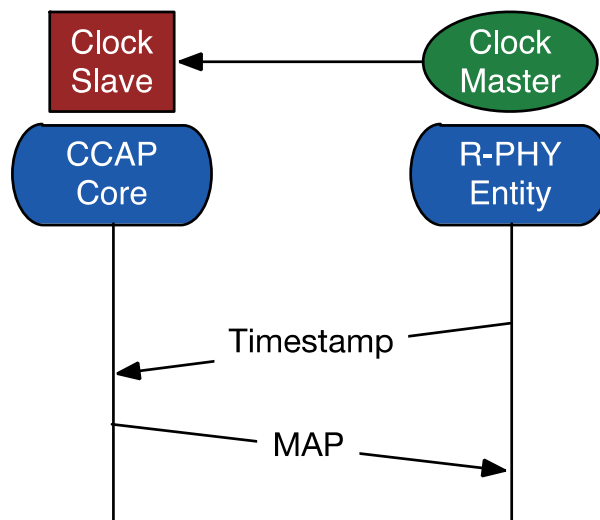

Figure 16 - R-DTI One-Way Reverse

“Reverse direction” refers to the RPD being a clock master and the CCAP-Core being a clock slave.

“One-way” refers to the RPD sending a timestamp to the CCAP-Core. The CCAP-Core filters the timestamp traffic, adds a DOCSIS MAP advance time, and uses the result to generate MAPs.

The advantage of the reverse method is that the physical clock in the RPD does not need to be adjusted. The act of aligning the clock in the RPD to the CMTS Core may cause enough disturbances in the DOCSIS symbol rate to cause the RPD to fail the DRFI specifications. The disadvantage of the reverse method is the scaling required at the CCAP-Core. The CCAP-Core may now have to track hundreds of clocks. This, however, is not unlike what EQAMs have to do for video de-jittering.

In the one-way reverse method, it is not known what the delay is from the RPD to the CCAP-Core. And perhaps it does not really matter. That delay, whatever it may be, becomes the engineering margin. The longer the network distance, and hence the delay, the more margin is required at the CMTS Core. The more jitter the network introduces, the more margin that is required at the CMTS Core. So, it is somewhat of a self-compensating mechanism.

8.2 R-DTI - Two-Way Reverse

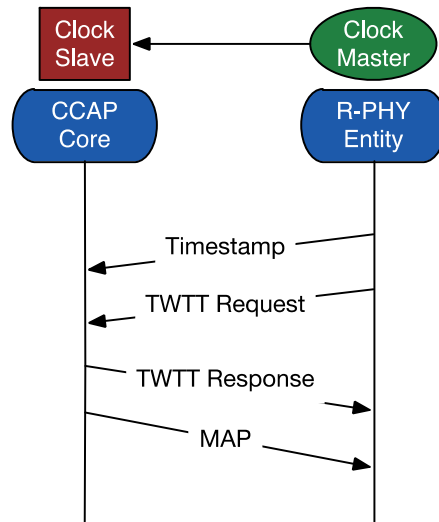

Figure 17 - R-DTI Two-Way Reverse

When the CCAP-Core receives a timing message from the RPD, it returns a timing message, creating what is known as a TWTT or two-way time transfer. TWTT collects outbound and inbound timestamps in each direction. Using these four timestamps, the one-way network delay can be calculated. That network delay can then be managed more precisely with the MAP advance.

There are different styles of signaling as to whether or not the timestamp from the RPD is in the same message as the request/response messages that actually get stamped on ingress and egress.

This method is superior to the one-way reverse method only if the timestamping of the timing packets happens in a timely and accurate manner. Timing mechanisms like this are usually hardware-based.

8.3 R-DTI - Two-Way Forward

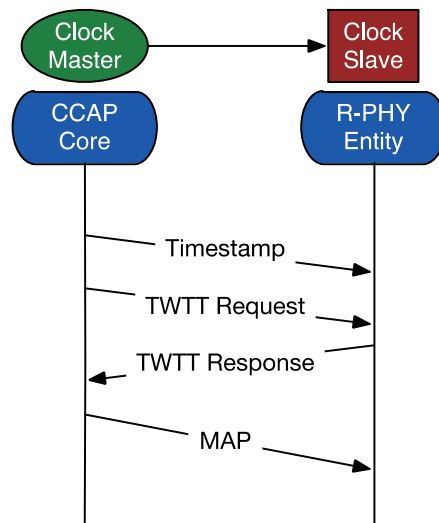

Figure 18 - R-DTI Two-Way Forward

In the two-way forward mode, the CCAP-Core is the clock master and the RPD is the clock slave. A TWTT protocol is run between the CCAP-Core and the RPD.

This is the classic clocking network as implemented in [IEEE 1588], and is included to allow very accurate timing. This method would be applicable when the network is [IEEE 1588] compatible.

8.4 Remote Scheduler

The Remote PHY specification permits the relocation of the DOCSIS scheduler from the CMTS Core into the Remote PHY Device. With the scheduler remotely located, there is no longer any timing requirement between the CMTS Core and the Remote PHY Device.

Although this sounds attractive at first, there are several drawbacks to remotely locating the scheduler. The first drawback is that the complexity of the remote node increases. The remote node now becomes subscriber aware and requires state information, QoS information and policy information are needed to track historical information for implementing rate shaping. This increases the complexity.

The second reason that a remote scheduler is not attractive is interoperability. If the CCAP-Core is from one vendor, the scheduler and node are from another vendor, and something goes wrong, troubleshooting is hard without a centralized scheduler as a reference point.

Current analysis shows that a centralized scheduler will work under currently known network conditions and that the timing design is quite manageable. The remote scheduler is a future option should it ever be needed.

8.5 Details about Timing

8.5.1 Packet Formats

The two-way forward method is intended to be an [IEEE 1588] implementation. It may also include a synchronous Ethernet (SyncE) implementation for frequency alignment.

The one-way and two-way reverse methods could be implemented with a light version of [IEEE 1588] or a Remote PHY-specific control packet.

8.5.2 Support for DTP

The DOCSIS Timing Protocol (DTP) was introduced with DOCSIS 3.1. DTP allows a CM to provide timing services, such as [IEEE 1588] and synchronous Ethernet, derived from DOCSIS timing. The DOCSIS Timing Protocol is explained in [MULPIV3.1].

8.5.3 Distances

DOCSIS defines a CMTS-to-CM, PHY-to-PHY distance of 100 miles (160 km) for DOCSIS 3.0 and 50 miles (80 km) for DOCSIS 3.1. Remote PHY retains these distances.

Because Remote PHY separates the DOCSIS MAC and PHY, there is an additional distance specification. That is the MAC-to-MAC, CMTS Core to CM distance. This distance is relevant when the CMTS Core is removed from the hub and placed in the headend or regional data center.

Hypothetically, there is no distance limitation to R-DTI. In practice, longer distances add jitter and latency that may impact services such as scheduling. Research is being conducted to see if R-DTI and the scheduling applications it supports could operate over a distance up to 2000 km, which is more than 10x the original DOCSIS transmission distance of 160 km.

This additional distance is intended to allow the CCAP-Core to be located at the headend or regional data center instead of at the hub site.

9 GCP GENERIC CONTROL PLANE

MHAv2 introduces a generic control plane (GCP) encapsulation protocol. GCP sets up a control plane tunnel over a generic transport protocol such as TCP. TCP provides a reliable transport, message acknowledgement, message segmentation for large messages, and windowing so multiple messages can be outstanding at once.

GCP imitates the major functionality that exists over a hardware bus between a CPU and a peripheral interface chip. It can read and write parameters, either directly to and from registers or with higher layer data structures. It can reset the device, power it up, or power it down. The device can send the equivalent of a hardware interrupt with the Notify command. GCP allows chips that were previously embedded to be located across a network interface such as Ethernet.

GCP can be used in any architecture where devices are connected with a network. GCP uses a protocol such as TCP/IP as its ultimate transport, so it is independent of both network topology and network technology. Specifically, although Ethernet is often used as the Layer 2 framing, any Layer 2 framing could be used, or be replaced on a per-hop network basis.

It is assumed that the remote device has enough intelligence to connect to a network, obtain an IP address, and operate a network stack. It is typical for remote devices to require configuration. If the technology that is in a new remote device has been well-defined in previous devices, then the previous data structures can be re-used with GCP.

For example, if a PHY technology like QAM (Quadrature Amplitude Modulation) has been well-defined in existing protocols like [MULPIv3.1], then the TLV (Type Length Value) data structures in [MULPIv3.1] could be re-used in GCP in this new device. This also provides the possibility for existing state machines and software code to be leveraged.

9.1 Tunneling Data Structures from Another Protocol

When GCP is used to tunnel the data structures from another protocol, the following nomenclature can be used:

GCP (tag)

where the tag is representative of the data structure being leveraged. For example, if the TLV data structures from a DOCSIS UCD (Upstream Channel Descriptor) message (see [MULPIv3.1]) are used over GCP, the result can be referred to as GCP(UCD).

9.2 Master and Slave

GCP is a generic control plane protocol that exists between a master entity and a slave entity. The intent is for the master entity to control the slave entity. GCP is able to re-use control plane concepts that are defined elsewhere but used in a new context.

GCP has a master entity and a slave entity. The master initiates reads and writes to the slave. The slave can initiate a notify message to get the attention of the master entity. This is shown in Figure 19 below.

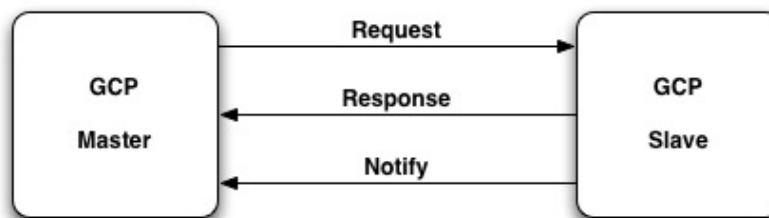

Figure 19 - GCP Block Diagram

GCP also has a peer-to-peer mode that permits both endpoints to simultaneously be both masters and slaves. The peer-to-peer mode is really just two independent master-slave modes, in opposite directions, on the same port number.

9.3 RPD Configuration via GCP

It is acceptable for systems to implement a subset of the GCP message set. GCP is a framework from which other systems and protocol infrastructures can be enhanced.

Following authentication, the CCAP-Core configures the RPD using the GCP (Generic Control Plane) protocol. Since the RPD is an extension of the CCAP-Core, the CCAP-Core contains all the necessary configuration information.

GCP allows control plane data structures from other protocols to be tunneled through its generic control plane. For example, GCP can use DOCSIS TLV tuples for the configuration of the RPD PHY parameters.

Note that the R-DEPI and R-UEPI protocols also contain a certain amount of configuration information. The MHAv2 paradigm is to keep R-DEPI and R-UEPI configuration focused on session signaling and to use GCP for RPD-specific configuration and operation.

The GCP protocol is authenticated and secured using IPsec. Encryption and/or message authentication codes (HMAC) can be applied to protect packets. IPsec keys are derived from the keying material created during the IKEv2 authentication process. IPsec session key exchange and renewal during the life of the GCP connection will be supported using IKEv2.

Appendix I Acknowledgements

On behalf of the cable industry and our member companies, CableLabs would like to thank the following individuals for their contributions to the development of this document:

Contributor	Company Affiliation
John T. Chapman	Cisco

On behalf of the cable industry and our member companies, CableLabs would like to thank the following individuals for their contributions to the development of the technology and participation in the Remote PHY Working Group.

Contributor	Company Affiliation	Contributor	Company Affiliation
Bill Powell	Alcatel-Lucent	Nagesh Nandiraju	Comcast
Brian Kurtz	Altera	Saifur Rahman	Comcast
Carlton Lane	Analog	Jorge Salinger	Comcast
Linda Mazaheri	Analog	Joe Solomon	Comcast
Tom Ferreira	Arris	Douglas Will	Comcast
Steve Foley	Arris	Jeff Ford	Complex IQ
Anand Goenka	Arris	Al Garrett	Complex IQ
Jeff Howe	Arris	Ony Anglade	Cox Communications
Hari Nair	Arris	Mike Cooper	Cox Communications
Andrew Chagnon	Broadcom	Samir Parikh	Gainspeed Networks
Victor Hou	Broadcom	João Campos	Get
Niki Pantelias	Broadcom	Even Kristoffersen	Get
David Pullen	Broadcom	Adi Bonen	Harmonic
Stuart Hoggan	CableLabs	Mike Patrick	Harmonic
Volker Lisse	CableLabs	Jim Chen	Huawei
Karthik Sundaresan	CableLabs	Hesham ElBakoury	Huawei
Nikhil Tayal	CableLabs	Karl Moerder	Huawei
Jun Tian	CableLabs	Jack Moran	Huawei
Andrew Sundelin	CableLabs Consultant	Guangsheng Wu	Huawei
Naor Goldman	Capacicom	Phil Oakley	LGI
Dave Fox	Casa Systems	Stan Bochenek	Maxim Integrated
Maike Geng	Casa Systems	Ajay Kuckreja	Maxim Integrated
David Claussen	Charter	Len Dauphinee	MaxLinear
Nobo Akiya	Cisco	David Huang	MaxLinear
Alon Bernstein	Cisco	Louis Park	MaxLinear
Brian Bresnahan	Cisco	Sridhar Ramesh	MaxLinear
John T. Chapman	Cisco	Patrick Tierney	MaxLinear
Hang Jin	Cisco	Scott Walley	MaxLinear
Tong Liu	Cisco	Rei Brockett	Pace/Aurora
Carlos Pignataro	Cisco	Nasir Ansari	Rogers
Sangeeta Ramakrishnan	Cisco	George Hart	Rogers
John Ritchie	Cisco	Kevin Kwasny	Shaw
Pawel Sowinski	Cisco	Lee Johnson	ST Micro
Don Strausberger	Cisco	Paul Brooks	Time Warner Cable
Yi Tang	Cisco	Kirk Erichsen	Time Warner Cable
Bill Wall	Cisco	Colin Howlett	Vecima
Gerry White	Cisco	Douglas Johnson	Vecima

Contributor	Company Affiliation	Contributor	Company Affiliation
Philippe Perron	Cogeco	Faten Hijazi	Xilinx
John Bevilacqua	Comcast	Alex Luccisano	Xilinx

Additionally, CableLabs would like to thank the DCA MSO team for their continued support in driving the specification development and the decision-making process.

Karthik Sundaresan, CableLabs
